

HUGO GERNSBACK
Editor

SHORT WAVE CRAFT

November

WORLD'S
LARGEST
SHORT WAVE
CIRCULATION

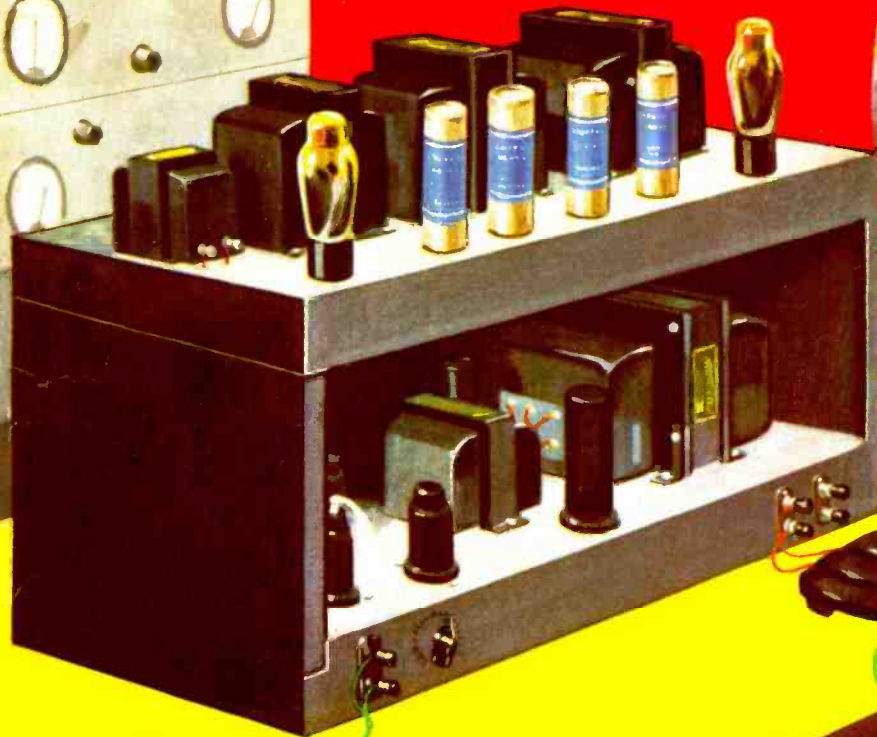

How to Build
The 6L6 Modulator
See Page 394

25¢

IN U. S. AND
CANADA

THE RADIO EXPERIMENTER'S MAGAZINE

*Doubles
World-Wide
Radio Enjoyment
and Slashes
Radio Current Bills
in Half!*



ELECTRIK-SAVER cuts radio wattage consumption 50%... enables 16-tube Midwests to consume no more current than ordinary 7-tube radios and to operate on voltages as low as 80 volts.



PUSH BUTTON TUNING
Finger tip tuning is made possible with the Midwest Automatic Push Button Tuning System. Doubles radio enjoyment.

Only **MIDWEST GIVES YOU**
PUSH BUTTON TUNING

plus Exclusive New
ELECTRIK-SAVER
for 1937

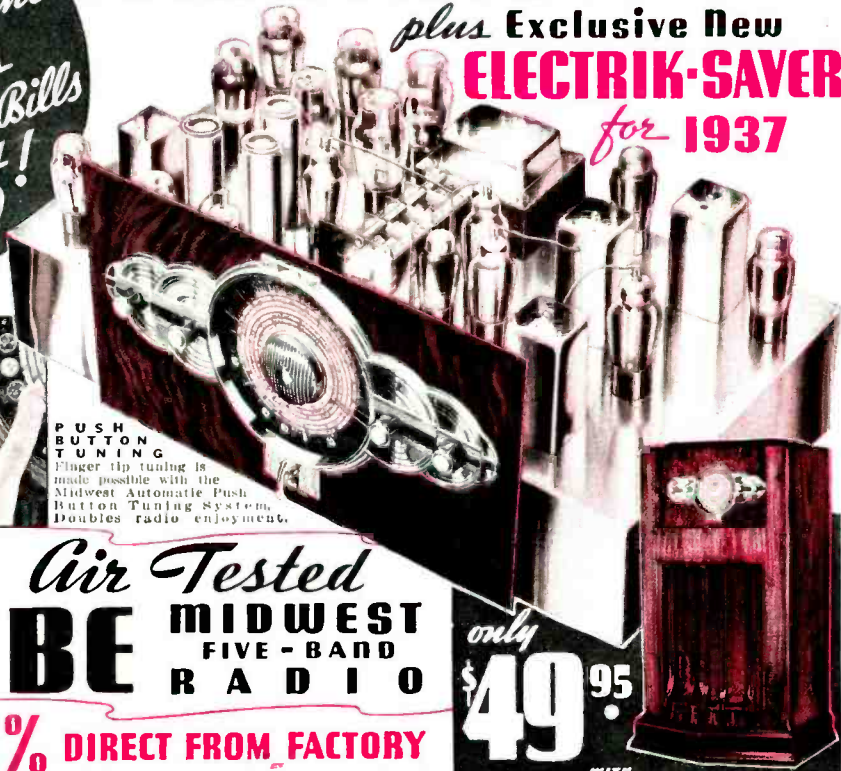

NEW 1937 Air Tested
16-TUBE **MIDWEST**
FIVE-BAND
RADIO

SAVE UP TO 50% DIRECT FROM FACTORY

only
\$49.95

NO middlemen's profits to pay! See for yourself that Midwest offers you greater radio values—enables you to buy the more economical factory-to-you way that scores of thousands of radio purchasers have preferred since 1920. Never before so much radio for so little money! Why pay more? The broad Midwest Foreign Reception and Money-Back Guarantee insure your satisfaction. You get 30 days FREE trial in your own home!

Once again, Midwest demonstrates its leadership by offering the world's most powerful and most beautiful ALL-WAVE 16-tube, 5-Band Radio. A startling achievement, it makes the whole world your playground. Powerful Triple-Twin tubes (two tubes in one!) give 18-tube results. This advanced radio is a master achievement, a highly perfected, precisely built, radio-musical instrument that will thrill you with its marvelous super performance...glorious crystal-clear "concert" realism...and magnificent foreign reception. The Dual Audio Program Expander gives a living, vital realistic quality to voice and musical reproduction.

74 ADVANCED 1937 FEATURES

This Super DeLuxe Midwest is so powerful, so amazingly selective, so delicately sensitive that it brings in distant foreign stations with full loud speaker volume on channels adjacent to powerful locals. Scores of marvelous Midwest features, many of them exclusive, make it easy to parade the nations of the world before you. You can switch instantly from American programs... to Canadian, police, amateur, commercial, airplane and ship broadcasts... to the finest and most fascinating foreign programs. With a Midwest, the finest entertainment the world has to offer is at your command. It is preferred by famous orchestra leaders, musicians, movie stars, and discriminating radio purchasers everywhere. You can order your Midwest "Air-Tested" radio from the new 40-page catalog with as much certainty of satisfaction as if you were to come yourself to our great factory. (It pictures the beautiful 1937 radios... in their actual colors!) You pay as little as \$5.00 down! Three iron-clad guarantees protect you: (1) A Foreign Reception Guarantee — (2) Absolute Guarantee of Satisfaction — (3) One-Year Warranty.



MIDWEST USES LESS Fill in coupon
CURRENT THAN AN NOW, and mail
ORDINARY LIGHT BULB **T O D A Y!**

WITH GIANT THEATRE-SONIC SPEAKER
(LESS TUBES)

TERMS AS LOW AS \$5.00 DOWN

Only **MIDWEST Gives You**

16 TUBES • 5 WAVE BANDS
9 TO 2200 METERS • ELECTRIK SAVER

- **PUSH BUTTON TUNING** •
- **AUTOMATIC AERIAL ADAPTION** •
- DOUBLE PUSH-PULL AUDIO**

30 DAYS FREE TRIAL!

MAIL COUPON TODAY
for
Free 30-DAY TRIAL OFFER
and 40-PAGE FOUR-COLOR Free CATALOG

MIDWEST RADIO CORPORATION
Dept. E-14, Cincinnati, Ohio
Without obligation on my part, send me your new FREE catalog and complete details of your liberal 30-day FREE trial offer. This is NOT an order.

Name _____
Address _____
Town _____ State _____



MY MIDWEST NOT ONLY MEETS BUT SURPASSES MY MOST CRITICAL STANDARDS.
Bing Crosby



NO SET THAT I HAVE EVER OWNED HAS BROUGHT IN FOREIGN RECEPTION SO CONSISTENTLY AND SATISFACTORILY.
Gloria Stuart



MIDWEST RADIO CORP.

DEPT. E-14 CINCINNATI, OHIO, U.S.A.
Established 1920 Cable Address MIRACD... All Codes

IT'S HERE

50,000 BUYS

GREATER THAN EVER



THE BIG 1937 RADIO CATALOG

FREE! Send the Coupon

AMATEURS

A complete collection of "Ham" equipment is unfolded in the Blue Ribbon Radio Catalog. From the S.W. kit to the swiftest professional type receiver. Transmitters—parts—tubes—accessories—aerials—hardware—all are here in our big "ham" section—and at new "lows" in price.

SET-BUILDERS

When you "build your own"—be certain that you get parts which will give you the kind of reception you want. From over 50,000 items in this catalog you make your selection. COMPLETE KITS AND PARTS FOR ALL Short Wave Craft CIRCUITS ARE DESCRIBED IN DETAIL.

EXPERIMENTERS

The vast experience of our technical personnel is at your service. Let us assist you in solving those knotty problems which crop up every so often—let us advise you on what parts to use. Save money, too.

SERVICEMEN

Shop at home with a Blue Ribbon Radio Catalog. Use your daylight hours for servicing—not shopping. The Blue Ribbon Radio Catalog can be your guide to greater profits. Lowest prices ever quoted on service instruments, parts, tubes, etc. GET YOUR COPY TODAY!

SOUNDMEN

Rely on WHOLESALE RADIO SERVICE CO., INC., to furnish you with the best in P.A. equipment—and at prices that give you plenty of room for decent profits. Our complete line described in the big P.A. section of the Blue Ribbon Radio Catalog.

• **T**HE world's greatest radio supply house scores again! In the 1937 "Blue Ribbon" Radio Catalog we give you the finest compilation of radio accessories you have ever seen. From hundreds of thousands of radio items available, our engineers have accepted only the best—after exhaustive tests in our own laboratories.

• **Here's Radio's Biggest Money's Worth —All In One Gigantic Book!**

Over 150 pages BIG—with more than 2,500 illustrations, and listing 50,000 items, this mastodonic catalog offers values never before obtainable. Only our tremendous purchasing power makes this possible. Our five completely stocked warehouses scattered throughout the country and our Interlocking Teletype System assure you of TWENTY-FOUR-HOUR shipments. At new low WHOLESALE PRICES, you will find a brilliant array of new receivers listed in this catalog, all wave and short wave, from the smallest 4 tube A.C.—D.C. compact to the colossal 21 metal tube console—fit for a king.

• **SEND FOR IT TODAY—IT'S FREE**



WHOLESALE RADIO SERVICE CO., Inc.
100 Sixth Avenue, New York, N. Y.
Rush FREE Blue Ribbon Catalog No. 654L

WHOLESALE RADIO SERVICE CO. INC.
CHICAGO, ILL. • NEW YORK, N.Y. • ATLANTA, GA.
901 W. JACKSON BLVD. • 100 SIXTH AVENUE • 430 W. PEACHTREE ST. N.W.
BRONX, N.Y. • NEWARK, N.J.
562 E. FORDHAM RD. • 219 CENTRAL AVE.

Name

Address

City State

Please mention SHORT WAVE CRAFT when writing advertisers

IN THIS ISSUE: PROMINENT SHORT-WAVE AUTHORS

Cohan • Stuart • Stokely • Cisin • Miller • Secor



HUGO GERNSBACK
Editor

H. WINFIELD SECOR
Managing Editor

GEORGE W. SHUART, W2AMN
Associate Editor

Combined With
Official SHORT WAVE LISTENER

Contents for November, 1936

Editorial—"The Radio Amateur Influence," by Hugo Gernsback	389
Philco Shows Television.....	390
Short Waves at the Olympic Games.....	392
Giant Television Camera Used at Olympics.....	392
Television and Short Waves Tomorrow!, Edward K. Cohan, Engineering Director CBS, Gives His Views to H. W. Secor.....	393
The 6L6 Modulator Handles 50 Watts, by Art Gregor....	394
Rural and Emergency Transmitter, by George W. Shuart, W2AMN.....	396
A Metal Tube U.H.F. Superhet, by George W. Shuart, W2AMN	398
Doerle 6-Tube "Band-Spread" S-W Receiver, by Guy Stokely, E.E.....	400
Junior "Space-Explorer" All-Wave 4, by H. G. Cisin, M.E.	401
Short Waves and Long Raves.....	402
Short Wave Scouts.....	403
\$5.00 for Best Short-Wave Kink.....	404
What's New in Short-Wave Apparatus.....	405
New Apparatus for the "Ham".....	406
"Air-Testing" the NC-100, by H. Edwin Ruth, 3rd, W2GYL	407
New 18-Tube Receiver Has Range 4.5 to 2400 Meters.....	408
New 6-Tube "Rack-Mounting" Set Has Many Features	408
New Short-Wave Sets and Devices.....	409
Radio Amateur Course, Conducted by Geo. W. Shuart....	410
Audio Oscillator and Amplifier.....	411
Let's "Listen In" with Joe Miller, "King of DX'ers".....	412
World S-W Station List, by M. Harvey Gernsback.....	413
Alphabetical List of S-W Stations.....	417
Short Wave Question Box.....	418
Short Wave League—"Scout News".....	420
When To Listen In.....	445



Certified Circuits

● **SHORT WAVE CRAFT** goes to a large expense in verifying new circuits. When you see this seal it is your guarantee that such sets have been tested in our laboratories, as well as privately, in different parts of

the country. Only "Constructional-Experimental" circuits are certified by us.

When you see our certified seal on any set described, you need not hesitate to spend money for parts, because you are assured in advance that the set and circuit are bona fide and that this magazine stands behind them.

SHORT WAVE CRAFT is the only magazine that certifies circuits and sets.

OUR COVER

● **THE** cover illustration shows the 6L6 Modulator, designed and built by Art Gregor, well-known contributor to the columns of *Short Wave Craft*. You will find this modulator fully described and illustrated on page 394.

COPYRIGHT, 1936, BY H. GERNSBACK

Published by **POPULAR BOOK CORPORATION**

404 N. Wesley Avenue, Mount Morris, Ill.
 Editorial and Executive Offices - - - - 99-100 Hudson St., New York, N. Y.
HUGO GERNSBACK, President - - - - **H. W. SECOR, Vice-President**
EMIL GROSSMAN - - - - - Director of Advertising
 Chicago Adv. Office - - - - - L. F. McCLURE, 919 No. Michigan Ave.
 European Agent: Gorrings's American News Agency, 9A Green St., Leicester Square, London W. C. 2
 Australian Agents: **McGILL'S AGENCY**, 179 Elizabeth St., Melbourne

Features in the Dec. "Fan" Issue

5-Meter Superheterodyne of improved design, by Geo. W. Shuart, W2AMN.

The "Forty-Niner"—a 2-tube FAN receiver for "lean" purses, by Stanley Johnson.

Even the Tugboats Go Short Wave!

2-Volt A.V.C. Super-het, by Harry D. Hooton, W8KPX.

The Hoover "Tinymite"—World's Smallest S-W Receiver!, by L. S. Hoover.

1937 Desk-Type Transmitter covering all bands from 80 to 5 meters by George W. Shuart, W2AMN.

SHORT WAVE CRAFT—Monthly. Entered as second class matter May 7, 1930, at the post office at Mount Morris, Illinois, under the act of March 3, 1879. Trademarks and copyrights by permission of H. Gernsback, 99-101 Hudson St., N. Y. C. Text and illustrations of this magazine are copyrighted and must not be reproduced without permission. **SHORT WAVE CRAFT** is published on the 1st of every month. Twelve numbers per year. Subscription price is \$2.50 a year in the United States and possessions and Canada. Foreign countries, \$3.00 a year. Single copies 25c. Address all contributions for publication to Editor, **SHORT WAVE CRAFT**, 99-101 Hudson St., New York, N. Y. Publishers are not responsible for lost manuscripts. Contributions cannot be returned unless authors remit full postage. **SHORT WAVE CRAFT** is for sale at all principal newsstands in the United States and Canada. European agents: Brentano's, London and Paris. Printed in U. S. A. Make all subscription checks payable to Popular Book Corporation.

OPPORTUNITIES *are many* for the Radio Trained Man

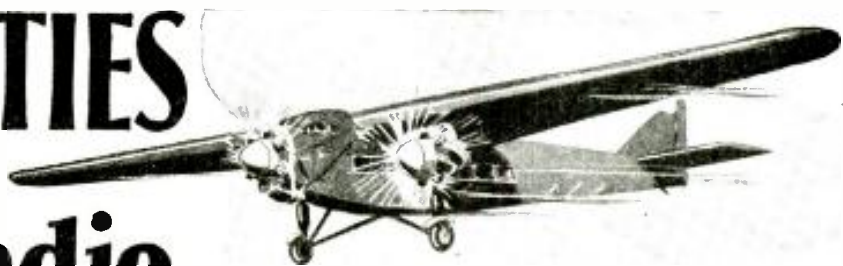

Don't be an untrained man. Let me show you how to get your start in Radio—a fast growing, live money-making industry.

Prepare for jobs as Assembler, Inspector and Tester—Radio Sales or Service and Installation Work—Broadcasting Station Operator—Wireless Operator on a Ship or Airplane, Talking Picture or Sound Work—**HUNDREDS OF OPPORTUNITIES** for a real future in Radio!

12 Weeks of Shop Training Pay Your Tuition After Graduation

We don't teach by book study. We train you on a great outlay of Radio, Television and Sound equipment—on scores of modern Radio Receivers, actual Broadcasting equipment, Television apparatus, Talking Picture and Sound Reproduction equipment, Code and Telegraph equipment, etc. You don't need advanced education or previous experience. We give you—**RIGHT HERE IN THE COYNE SHOPS**—the actual practice and experience you'll need for your start in this great field. And because we cut out all useless theory and only give that which is necessary you get a practical training in 12 weeks. Mail coupon for all facts about my school and training methods.

TELEVISION *and* TALKING PICTURES

Television is sure to come as a commercial industry. Whether this year or later, it will offer opportunities to the man who is trained in Radio. Here at Coyne you learn Television principles, and work on actual Television equipment. Talking Picture and Public Address Systems offer opportunities to the Trained Radio Man. Here is a great new Radio field which is rapidly expanding. Prepare NOW for these wonderful opportunities! Learn Radio Sound Work at COYNE on actual Talking Picture and Sound Reproduction equipment.

ARRANGE TO FINANCE YOUR TUITION

I am making an offer that is the most unusual ever made by a school. I'll take you here in my shops and give you this training and arrange a plan for you to pay your tuition in small monthly payments extending over an 18-month period, the first payment to be made 5 months after you start school. I know a lot of honest fellows haven't much money these days, but still want to prepare themselves for their start towards a real job, steady work and better pay.

Mail the coupon for all details of this "Pay Tuition after Graduation Plan."

ELECTRIC REFRIGERATION AIR CONDITIONING

To make your training more valuable, I include—at no extra cost additional instruction in Electric Refrigeration, Air Conditioning and Diesel Engines, taught you by personal instruction and actual work on real equipment.

PRACTICAL WORK At COYNE in Chicago

ACTUAL, PRACTICAL WORK. You build and service radio sets. You get training on real Broadcasting equipment. You construct Television Receiving Sets and actually transmit your own Television images over our Television equipment. You work on real Talking Picture and Sound equipment. You learn Wireless Operating on Actual Code Practice apparatus. We don't waste time on useless theory. We give you the practical training you'll need for

your start in Radio—in 12 short, pleasant weeks. If you desire code, this requires additional time for which there is no extra charge.

MANY EARN WHILE LEARNING

You get Free Employment Service for Life. And don't let lack of money stop you—my plan makes it possible to get Coyne training with very little money. Many of our students earn part of their living expenses while going to school and if you should need this help just write to me. Coyne is 37 years old. Coyne Training is tested. You can find out everything absolutely free. Just mail coupon for my big free book!

H. C. Lewis, Pres. RADIO DIVISION Founded 1899
Coyne Electrical School
500 S. Paulina St., Dept. 86-2K, Chicago, Ill.

Mail Coupon Today for All the Facts

H. C. LEWIS, President
Radio Division, Coyne Electrical School
500 S. Paulina St., Dept. 86-2K, Chicago, Ill.
Dear Mr. Lewis:—Send me your Big Free Radio Book, and all details of your Special Offer, including additional instruction in Electric Refrigeration, Air Conditioning and Diesel Training and your "Pay After Graduation" offer.

Name.....
Address.....
City..... State.....

Please mention SHORT WAVE CRAFT when writing advertisers

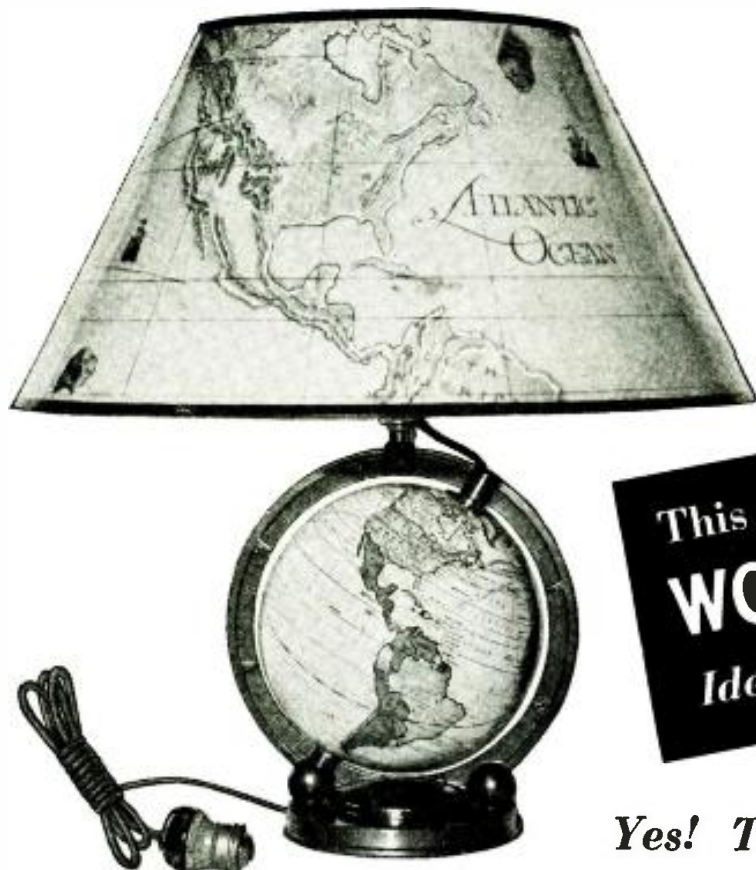

Free!

This useful and ornamental
WORLD-GLOBE LAMP
Ideal for short wave fans

Yes! The globe revolves!

NEVER in the six years that SHORT WAVE CRAFT has been published, have we found *anything* that is as *useful* and *ornamental* as the WORLD-GLOBE LAMP we now offer free to our readers.

This beautiful WORLD-GLOBE LAMP measures 17½" high. The attractively colored shade, with nautical and map designs, is 8" in height and 16" in diameter. It is made of fine quality parchment, highly glazed, to assure long life. A slightly damp cloth quickly removes dust from the shade. The 6¼" globe, printed in many colors, has a *full meridian*, and *rotates*. Hundreds of names—countries, cities, rivers, oceans and others are *clearly printed on the globe*.

Another feature on this WORLD-GLOBE LAMP is the *movable hour scale* found at the north pole. This permits determining the correct time in any part of the world.

The metal parts are finished in antique bronze. A piece of heavy green felt is glued under the base, therefore it may be placed *anywhere*, without fear of marring table, desk, etc.

The weight of the WORLD-GLOBE LAMP is nearly three pounds. When packed for shipping, six pounds.

Here is the way to get this beautiful prize. Fill in the coupon in the left hand corner—cut it out and mail it to us together with your remittance of \$2.50. You will receive a full year's subscription (12 months) to SHORT WAVE CRAFT—the *greatest short-wave magazine in the world today*. In addition, we will send you absolutely FREE one of these handsome WORLD-GLOBE LAMPS. *Old subscribers* may renew their subscription now for another year following expiration of their present one and still receive this WORLD-GLOBE LAMP.

Only a limited number of WORLD-GLOBE LAMPS are available. Take advantage of this offer *without delay* in order to insure receiving *your free gift*. RUSH THE COUPON TODAY.

Long Needed Article

Gentlemen:
Regarding your wonderful GLOBE-LAMP, please accept my sincere compliments for a long needed article and trust you'll be swamped with orders.
(Signed) W. H. Herman,
7704 Sagamore Ave.
Cleveland, Ohio.

All Admired It

Gentlemen:
I am perfectly satisfied with your GLOBE-LAMP. It is just what you have said about it in every way. All my family and friends have admired it. It arrived in perfect condition. Many thanks and the best of good luck to you and your SHORT WAVE CRAFT.
(Signed) William Owens,
30 North Fifth Street,
Bangor, Penna.

WHAT THEY SAY ABOUT THE WORLD-GLOBE LAMP!

MAIL COUPON TODAY!

Very Well Pleased
Gentlemen:
I am very well pleased with my Globe-Lamp. It presents a handsome and novel appearance and is most appropriate when located near an all-wave radio set. When lighted at night, it sheds a warm, soft glow, and the parchment shade shows up most attractively. Unquestionably, the combination of the lamp and SHORT WAVE CRAFT for \$2.50 is a real bargain.
William E. Sloan, Jr.,
87 Exchange Street,
Rochester, New York.

Unique, Beautiful and Useful
Gentlemen:
The Globe-Lamp arrived today, also the magazine. Congratulations on a premium so unique, beautiful and, above all, useful, especially to DXers on the short-wave bands. I already have a large globe, but I expect to use the small one much more frequently and with equal satisfaction. It goes fine with the new Hammarlund "Super Pro."
T. E. Warnock,
99 Elm Street,
Meriden, Connecticut.

Wouldn't Take \$15.00 For It
Gentlemen:
I received the Globe-Lamp and I am very much pleased with it. I think it is handsome and think a good deal of it. I wouldn't take \$15.00 for it. The lamp sets on top of the radio and is handy to glance at when I hear the foreign stations.
Warren G. Ryder,
Barnstable Radio Shop,
Barnstable, Mass.
P.S.: Many thanks for the lamp!
WGR

SHORT WAVE CRAFT SWC-1136
99 Hudson Street, New York, N. Y.

Gentlemen: Enclosed you will find my remittance of \$2.50 (plus.....cents shipping charges) for which enter my subscription for SHORT WAVE CRAFT for one year (12 issues). This amount entitles me to a WORLD-GLOBE LAMP free. See chart next to coupon for shipping charges on WORLD-GLOBE LAMP.

() Enclosed find my remittance of \$2.50. Please send me the WORLD-GLOBE LAMP by express, collect.

Name

Address

City State

Send remittance in form of check or money order—register letter if it contains cash, stamps, or currency.

How to Order Your WORLD-GLOBE LAMP

Simply fill in the coupon at the left and mail together with check or money order. Register letter if cash or coin is sent. To cover shipping charges on WORLD-GLOBE LAMP, add to your remittance the amount indicated. If you are located: East of the Mississippi add 35 cents; Between the Mississippi and the West Coast add 70c; Foreign Countries add \$1.30. Any excess remittance will be refunded.

SHORT WAVE CRAFT

99 HUDSON STREET

NEW YORK, N. Y.

Please mention SHORT WAVE CRAFT when writing advertisers



The Radio Amateur Influence

An Editorial by Hugo Gernsback

● IT has often been said that the radio amateur is not made, but rather that he is born. This does not mean that he comes into the world fully equipped with all the necessary knowledge, but it is a fact that many of the inherent qualities that make an amateur are really inborn. It also means that amateurs as a class have been careful in choosing their ancestry.

Not everybody has the mental equipment and other necessary qualities that make up the radio amateur. Indeed, in the whole world today, there are less than one hundred thousand qualified "hams," who would be accepted as such.

It is true that many people can and do learn the code, but that is only a minor amateur accomplishment. Other traits and a good deal of practical education, plus something that might best be called "amateur sense" is necessary to make a successful "ham." Just as no bridge-player can be considered great unless he has that elusive quality known as "card sense"—so no radio "Ham" will be worth his salt unless he has the inborn instinct of "amateur sense." This latter in a short sentence, comprises: radio (in the technical sense, from the ground up), a capacity for hard work, a keen intelligence, an analytical mind, as well as a studious nature. This may sound like a large order, and it is. Nor is this an entire catalogue of all the virtues which a successful amateur must have if he is to be worth his salt. He must, for instance, have good health. That is if he is to stand the ordeal of staying at his key or his "mike" from eight o'clock in the evening until four the next morning, and perhaps longer should the necessity arise. He must also be a good electrician, must have a good grounding in physics and mechanics, and usually know something about mechanical draftmanship. And, when it comes to mathematics, he must be more or less expert at it, too. Difficult requirements, it is true, but all quite necessary. And this is the main reason why there are not ten million "hams" or radio amateurs in this world, and probably never will be.

All of these remarks are not made with the idea of patting the amateur on the back and extolling his virtues. This has been done so many times by others that there is no necessity at this late date to put a halo around the amateur's head.

The point I do wish to make, however, is that it is not generally recognized that amateurs as a class have always been outstanding in their endeavors. It would seem that the rigorous training, the hard work and resourcefulness of the average amateur makes him better equipped to rise in the radio or another profession, quicker and with more success than the average man not gifted with the mental radio amateur equipment.

Few people realize that in the radio profession, for instance, a very large percentage of radio engineers and executives were formerly radio amateurs, and that the radio industry has for years drawn upon the radio amateurs when in need of specialized technical personnel.

And when it comes to character building, there is no better school than the radio amateurs'. For a period of over thirty years, parents have realized that it is a good investment to allow their sons to spend money on radio equipment, because they soon came to realize that this kept the boys at

home and away from bad influences. They came to recognize that by keeping the boy interested in this serious hobby, the young man would grow up under wholesome surroundings, which to most parents nowadays is of the highest importance. Once parents recognized the fact that their son would have to take a government examination in order to become a qualified amateur, they knew that the hobby had a real purpose behind it, which, in time, might pay handsome dividends.

Not every amateur is a college graduate because all families cannot afford to send their sons to college, but the money invested for radio transmitters and receivers has often been invested with better results than if a larger sum had been expended by sending the young man to college. This is no reflection on colleges but rather praise of those amateurs who have not been to college and who have not found this a handicap in later years. As a matter of fact, a number of non-college "hams" hold as high positions as those who have been to college. On the other hand, it is also true that not every radio amateur becomes a radio engineer, or, indeed, goes into the radio profession later on. Quite to the contrary, the majority probably do not. There are successful lawyers, dentists, doctors, manufacturers, who were once amateurs, and each one will tell you that the training which they got when they were an active amateur was partly responsible for their present position. What is the average length of time that an amateur is active?

No exact data is available, and it is doubtful if a correct answer can be given. One thing is certain, once an amateur, always an amateur. That does not mean that the successful attorney who was an amateur fifteen years ago still has his "shack" and still "pounds brass."

But it is true, also, that many of the ex-amateurs sooner or later get the "itch" again and, if conditions permit, revert to their "old love." We know of an outstanding dentist in the East who dropped active amateurism when he became too busy with his profession, but after five years he again became imbued with the spirit, and is now operating a new and glorified ham station in his spare time. This condition is true of many ex-amateurs, because what we have learned once as an amateur is never forgotten and sooner or later he will wish to see what is new in the art and what can be accomplished with the latest equipment.

On the other hand, there are literally tens of thousands of "hams" who never quit, and, while they may not stay at their keys until five o'clock in the morning for a large part of the week, they still have their licenses renewed right along and stay active.

Outsiders often have vented the complaint that amateurs were apt to be snooty, "stuck-up," and that they consider themselves better than other mortals. All this is probably true, and nothing can be said as a defense of it. It is also true of mathematicians, astronomers, and other mortals who are continuously working on a higher plane than the rest of the human herd. And unless you are a radio amateur and have been one for many years, you probably cannot appreciate this. The fact remains that radio amateurs are what they are, because there is little doubt that as a clan they have qualities which the rest of us may well envy.

SHORT WAVE CRAFT IS PUBLISHED ON THE 1st OF EVERY MONTH

This is the November, 1936 Issue—Vol. VII, No. 7. The Next Issue Comes Out November 1

SHORT WAVE CRAFT, Published monthly at Mount Morris, Ill.
 EDITORIAL and EXECUTIVE Offices, 99 Hudson St., New York City

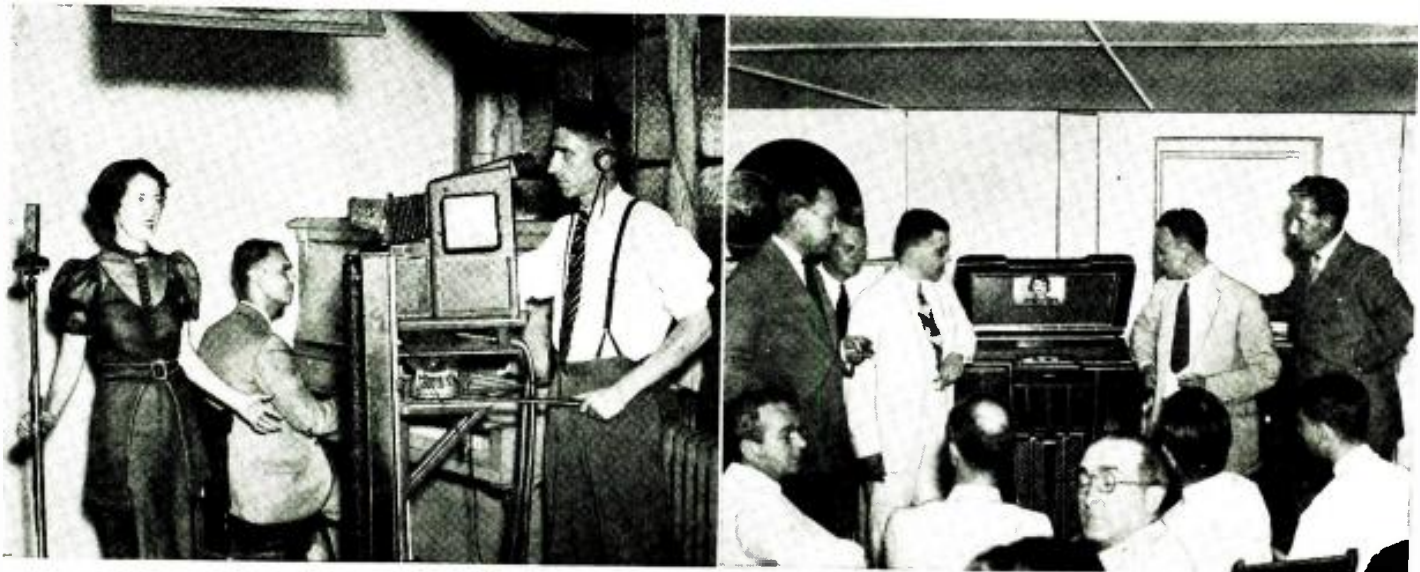

Above at left—A scene in the Philco Television Studio as Betty McNellis sang and Charles Stec accompanied her on the piano. At right—The Philco television receiver as demonstrated to representatives of the press recently in Philadelphia. The image appears on the mirror in the lid of the cabinet.

PHILCO Shows TELEVISION

● THE other day a number of editors from New York and Philadelphia were invited to the first public demonstration of television by the Philco television engineers. Unknown to most of the television world, Philco has been carrying on experimental television work for over eight years, but rather than make a premature announcement they have deemed it the better plan to wait until an appropriate development stage had been reached, before exhibiting even this experimental television apparatus to the public.

The Philco representatives at the demonstration were emphatic in pointing out that television, as far as its everyday use by the public is concerned, was not "just around the corner." A glance at the accompanying photos shows the appearance of the television receiver in its experimental form as demonstrated recently in Philadelphia. At that time the image as well as sound accompaniment was transmitted by radio over a distance of about seven miles. Later a second demonstration was given

A recent demonstration by the Philco engineers of their latest television apparatus was very promising. The pictures were of good definition and they were accompanied by sound. The images were transmitted on a frequency of 51 mc. and the voice on 54.25 mc. The images were transmitted by radio a distance of seven miles.

in the studio and laboratory, where the image currents were transmitted over a concentric transmission line about 75 feet in length.

In the radio transmission of the image the pictures were broadcast on 51 mc. and the sound on 54.25 mc. It is interesting to point out at this juncture that the separation between the sound and image transmission frequencies, amounts to 3.25 mc. which corresponds to the new RMA standard. The spacing between the picture and sound carriers as used by RCA in their Empire State Bldg. transmission in New York City, is 2.25 mc.

Two Receivers Used for Image and Voice

In the Philco television receiver here shown, two complete superheterodynes are employed. On one superhet the

image signals are "tuned in," while the accompanying sound on its own particular carrier frequency is tuned in on the second superhet. In experimental tests a single tuning control for

both sound and image receivers has been employed, but the two receivers have been left independent in most of the tests as this is only an experimental model and it gives greater flexibility in tuning. In the future a fixed ratio between the image and sound carrier frequencies will be preserved, and in that way the manufacturer of the television receiver of tomorrow will be enabled to "lock" the oscillator controls for both the sound and image receivers to a single control tuning shaft and dial.

The size of the television image as seen by the observers in the Philadelphia demonstration was 7 1/2 by 10 inches. A negative image is transmitted at the studio and 345 lines were used in scanning. Sixty pictures per second were transmitted with interlaced scanning, the proportions of the picture or aspect ratio being 4 to 3. The per-

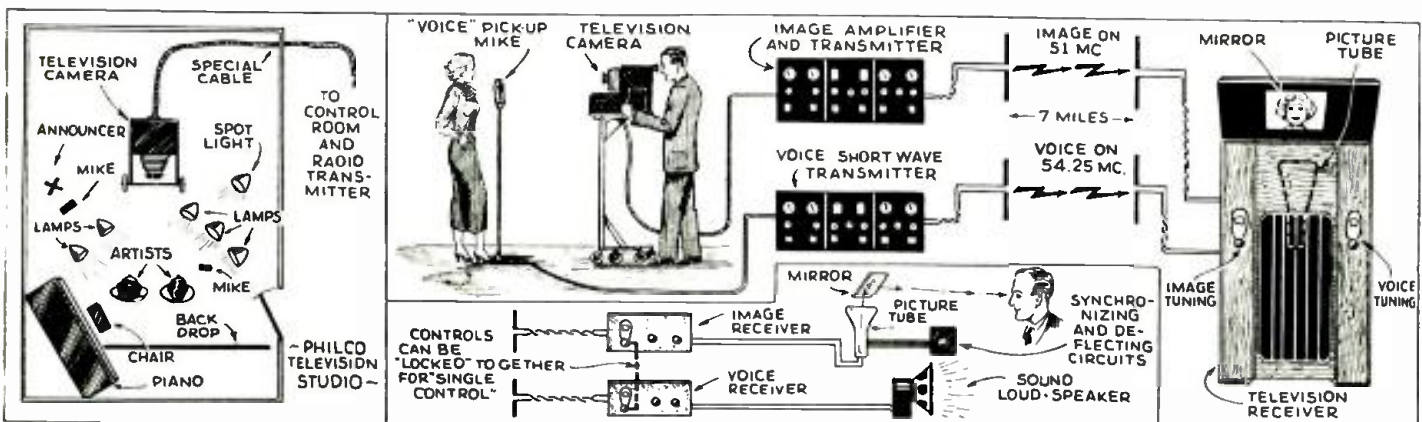

This diagram shows the principal elements of the Philco television system as recently demonstrated in Philadelphia. The image, as well as the accompanying sound, each transmitted on its own carrier frequency, was transmitted 7 miles.



Front view of the Philco television receiver with "image" and "sound" tuning dials at right and left of cabinet.



Top-center, image of Jean Muir, movie star, as reproduced by radio over a distance of 7 miles, with marked section greatly enlarged to show how image is built up.

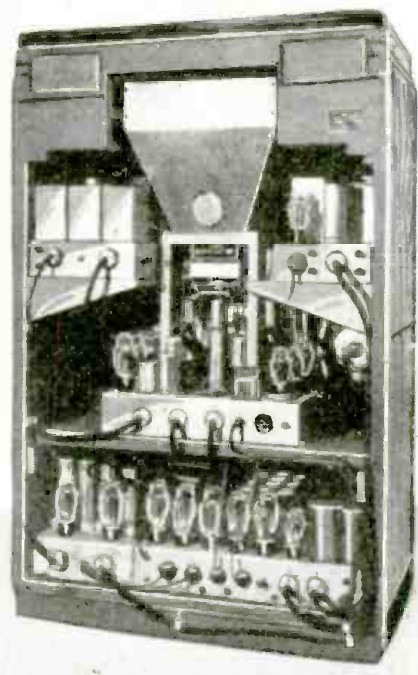

Above—Rear of television receiver, with power-supply units, image and sound receivers, also "picture tube" in center.

centage of television signal devoted to synchronizing is 20 per cent, and the synchronizing signal is of the narrow vertical type. The channel width employed is 6 megacycles.

During the time of these experiments the license for the visual broadcasting station W3XE was received and experimental transmissions were commenced in 1932. We thus pass from the second stage into the third, in which 240 line pictures were transmitted.

Philco's Television Activities Started in 1928

In 1928 Philco engineers were experimenting with 60 line scanning discs. This can be called the first stage of development. It was followed by a picture of considerably more lines, using electronic methods.

Special Television Tubes Developed

Hand in hand with Philco's television circuit advances research work progressed in their vacuum tube laboratory on the special tubes used in their system. (Continued on page 426)

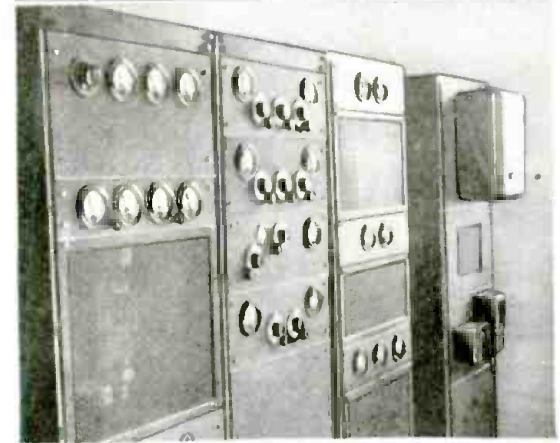
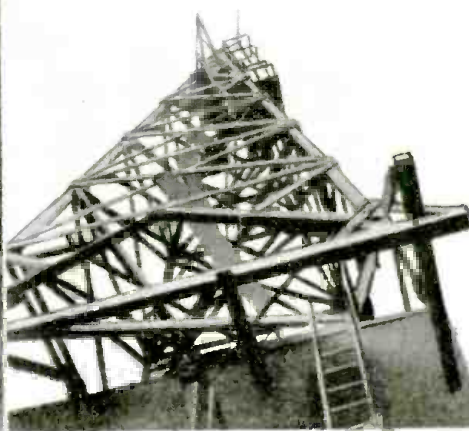
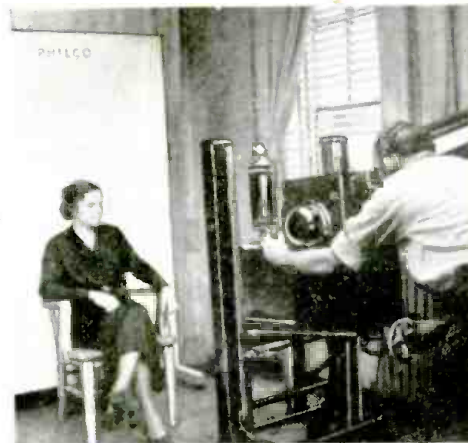

Three photos above show respectively — Scene in Philco television studio; center, television control room; and at right, tower supporting ultra-high frequency antennas used to broadcast pictures and sound over Philadelphia. At left—Philco U.H.F. sound transmitter operating on 54.25 mc. At right—Philco television engineers, from left to right: S. F. Essig, W. N. Parker, A. F. Murray, F. J. Bingley, P. J. Koukle, H. Branson, N. S. Bean.



Short Waves at the Olympic Games

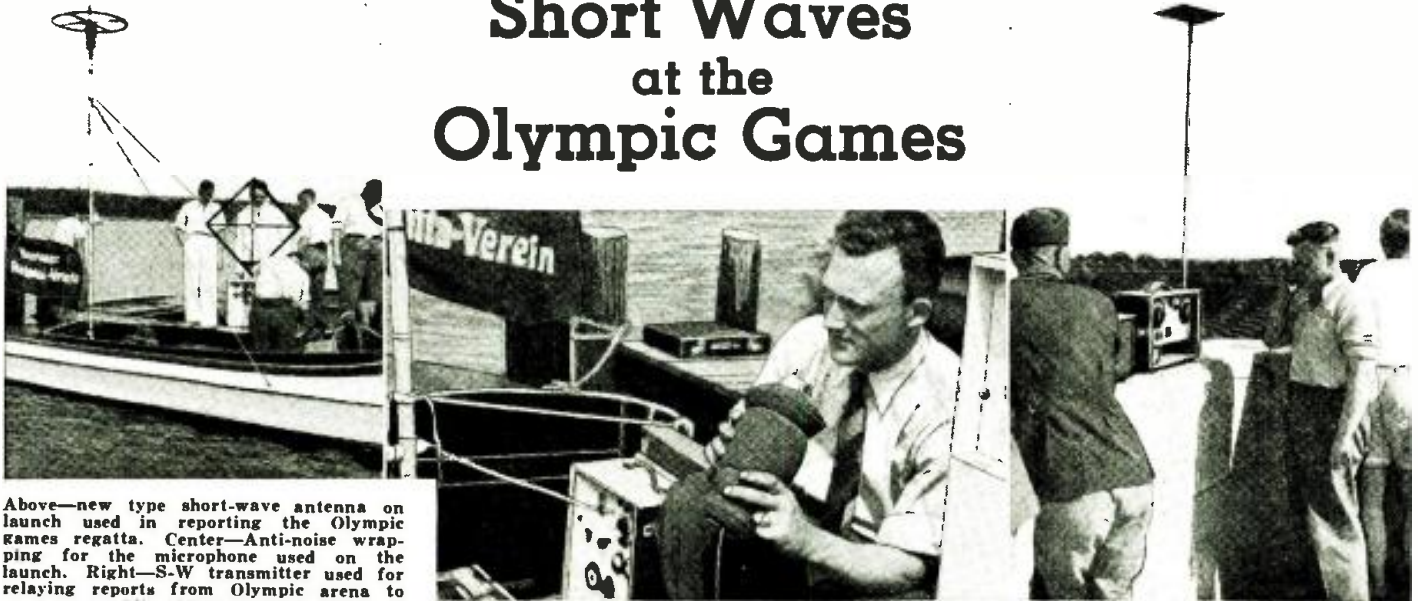

Above—new type short-wave antenna on launch used in reporting the Olympic Games regatta. Center—Anti-noise wrapping for the microphone used on the launch. Right—S-W transmitter used for relaying reports from Olympic arena to public-address system.

● THE photo at the left of the accompanying group shows a novel ultra-short wave antenna installed on a "News" launch. This motor-boat "Nibu" was used during the Olympic regatta and the U.S.W. set on the launch was used to transmit the latest news of the progress of the racing crews to the newspapers and other "news centers."

The central photo of the group shows anti-noise enclosure for a microphone as employed aboard the launch previously described. The microphone, together with its pre-amplifier tube, is wrapped in sponge rubber to exclude all extraneous noise. The reporter is shown speaking into the microphone. The right-hand photo shows a special light-weight short-wave transmitter, of

the type used for flashing the results of the various contests conducted in the Olympic Stadium at Berlin. This particular short-wave transmitter was used to flash news to a "local" receiving set which in turn was connected with the public address system of the stadium. Even though a great many microphone connection boxes were in-

(Continued on page 424)

Giant Television Camera Used at Olympics

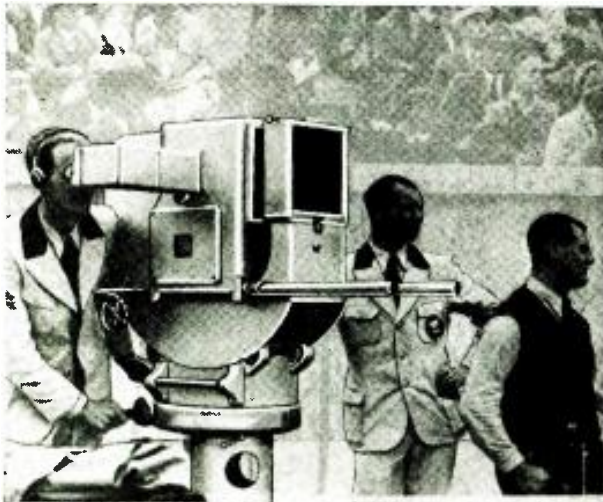

↑ Huge television camera for direct pickup of outdoor scenes, used at the recent Olympic games at Berlin. It was invented by Dr. Zworykin of RCA.



← Left—The television camera equipment with huge telephoto lens used to focus objects clearly even 400 feet away.

assembled, because the scene to be transmitted is only a few feet away.

The most important part of this camera is a device called the Iconoscope. It was invented by Dr. Zworykin of the R.C.A. and now used (by the designer of this camera—the Telefunken Co.) to convert the optical image (as caught by the lens) into electrical impulses. These impulses are transmitted to the radio listener via short waves, and by means of a television receiver retransformed into an optical image. The device was used at the Olympic Games in Berlin.

The camera is equipped with a huge telephoto lens about 15 inches in diameter (and 1600 millimeter focal distance). The weight of the large lens is about 100 pounds.

The outfit looks like a clumsy affair, but since it can pick up everything even scenes or objects 400 feet away, a higher degree of mobility is not re-

quired.

Large Size Television Images Shown in Theater—One of the great obstacles to the practical introduction of television into the home has been the small size of the reproduced image. One had to sit near to the front of the receiver and the performance could not be enjoyed by a large gathering. An im-

(Continued on page 424)

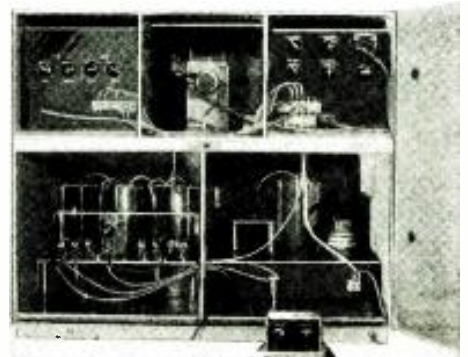
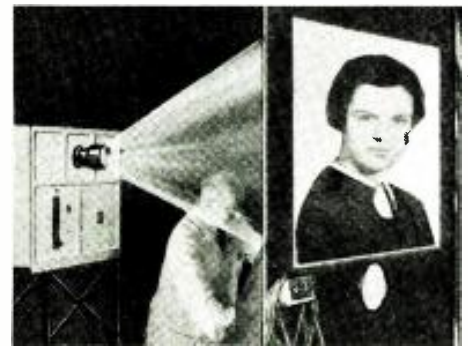

● THE photos above show the newly designed German television camera which may be used in connection with a telephoto lens and without such a lens. In the top photo the lens is dis-

Two photos at right show new German television projector and screen for use in movie theaters. The image on the screen as shown measures about 3 by 4 feet. The lower photo shows control panel and in the center box there is mounted the new "flat-end" cathode tube, which operates with a plate voltage of 20,000.

TELEVISION and SHORT WAVES To-morrow!

**EDWARD K. COHAN, Engineering Director CBS,
Gives His Views to H. W. Secor**



Edward K. Cohan, Director of Engineering, Columbia Broadcasting System.

One of the best posted technical men in America today is Edward K. Cohan, Engineering Director of the Columbia Broadcasting System, which comprises a network of 105 broadcast stations. CBS has had experience in "television broadcasting" and they also use ultra short wave apparatus in picking up spot-news. Mr. Cohan's views, therefore, are of the highest import today when public interest in television and ultra short waves is growing rapidly.

● **TELEVISION** and *ultra short waves* are two of the most widely discussed subjects among radio men everywhere today. In view of the fact that CBS had practical experience in operating a television transmitter on a regular daily schedule a few years ago, and also performed considerable research work, the writer considered Mr. Edward K. Cohan, Director of Engineering of the Columbia Broadcasting System, a logical and capable authority to answer the great influx of questions which arise daily on this subject. Mr. Cohan graciously assented to give his valued opinions on the questions which follow:

Q. Is CBS interested in ultra short waves for use in broadcasting programs? If a transmitter is now in use, what is the frequency and its future purpose?

A. CBS is already operating two high frequency broadcasting stations and has applications pending with the FCC for additional ones. It is impossible to predict, at this time, just what value such stations might prove to be in the broadcasting of programs and it is for the purpose of finding the answer to this question that the present transmitters are in experimental operation. They are: station W2XDV in New York, operating weekdays from 6 P.M. to 11 P.M., Saturdays and Sundays from 1:30 P.M. to 6 P.M. and 7 P.M. to 10 P.M., current New York time, on a frequency of 31600 kilocycles and a power of 50 watts; and station W9XHW, Minneapolis, Minn., operating weekdays from 5 P.M. to 11 P.M., Saturdays and Sundays from 8 A.M. to 11 P.M. current Minneapolis time, on a frequency of 31600 kilocycles and a power of 50 watts.

Q. In using U.S.W. for spot-news "pickups" with portable set carried on the news reporter's person, do you think that one meter (or 300 mc.) transmitter frequency is about the highest practicable frequency? Any immediate future new angles on this u.s.w.?

A. One meter (or 300 megacycles) is about the highest practical frequency today, but only because of the difficulty in obtaining suitable equipment to oscillate at higher frequencies. While such equipment is available for laboratory test work, its stability is not good enough to permit it to be assembled in the type equipment necessary for portable field work, bearing in mind the ruggedness and simplicity of control necessary in such equipment.

Is CBS Interested in Television?

Q. Is CBS interested now or likely to be in the near future in TELEVISION broadcasting? Any television research being carried on by CBS technicians or by any commercial laboratory for CBS?

A. Obviously, CBS is interested in television broadcasting. For further information on this subject we refer you to Mr. Paley's address before the FCC Engineering Hearing in Washington, June 16, 1936.

Q. Do you believe the cathode ray tube or a tube of this general type will be the ultimate means of scanning and reproducing the image of transmitter and receiver?

Or, what do you think of the possibility of mechanical scanning with an improved mirror or lens system, using either vibrating elements or scanning discs at such high ranges as 300 to 450 lines?

A. While the consensus of opinion in America points to the cathode ray tube, or a tube of this general type, as the most desirable means of scanning and reproducing a television image, progress is still being made with mechanical systems, notably in Europe, and it would be unwise, at this early date, to rule out the eventual "perfection" of a satisfactory mechanical system. Line for line, reproduction of a mechanical system is superior to an electronic system.

Q. Do you still believe that the future television transmission of both voice and image may be carried on by doubly modulating a single wave length or frequency and picking up the respective components of this single wave by means of two receivers or a double receiver, as experimented with by your television stations several years ago? If not, what are the disadvantages of that system, in view of the fact that it simplifies the transmission so markedly, as compared to the two individual wavelengths now being used by RCA, Philco, et al?

A. The main difference between the present method of transmitting sight and sound side-by-side, and the method experimented with by Columbia several years ago, is in the "spacing" between the sight and sound channel. The sound channel takes up such a negligible part of the transmission band, as compared to that occupied by the image transmission, that for all practical purposes it can be considered as one continuous band. The present method of referring to them as two bands side-by-side is simply a matter of clarity.

Will Television Stay on High Frequency Waves

Q. Do you think that the present wave-length of 5 to 6 meters will be retained for television transmission in the near future, or do you believe it possible that a higher wave length may be employed for television by using a combination of special scanning tricks, whereby the effect of a high lineage scanning is obtained by some optical means?

A. While it is always possible that someone may come along with a revolutionary system which will enable high definition television to be transmitted in a relatively narrow band, no research work, up to the present time, indicates that this

is likely to be accomplished in the near future.

It may be remembered that four or five years ago Mr. Farnsworth made a statement to the FCC indicating that he was well on his way to the solution of this problem. In justice to Mr. Farnsworth, it must be said that he was, at that time, absolutely sincere in his statement and his opinion was backed up by some of the country's foremost physicists. Further mathematical study by Mr. Farnsworth and his associates pointed out the fallacy of their prediction.

Q. From your experience with the CBS television transmitter and studio as operated several years ago, do you think

(Continued on page 428)

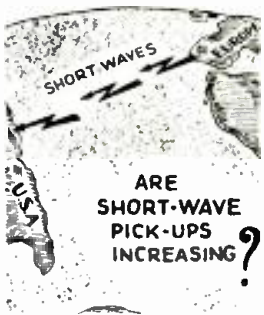

The 6L6 MODULATOR

HANDLES 50 WATTS . . .



Complete modulator, including the crystal microphone.

● THE famous 6L6 tube, although not very old, has become one of the most popular of all tubes manufactured and is, to say the least, the most interesting. Previous articles in *Short Wave Craft* have shown its adaptability to transmitting apparatus in the R.F. portion and in this article there is described a *modulator* using them in the output stage.

Two of these tubes in Class A-B in this modulator will deliver over 50 watts of audio and are capable of modulating an R.F. amplifier with inputs up to 100 watts. This modulator is designed to work in conjunction with a crystal microphone and uses metal tubes throughout, except in the *power-supply*. The diagram reveals that we start out with a hi- μ triode, as the first stage of speech amplification, a low- μ triode in the second stage of speech, two in push-pull as drivers for the push-pull 6L6's. Resistance coupling is used in the first two stages which employ a 6F5 and a 6C5. The speech amplifier is "transformer-coupled" to the *driver* stages which, in turn, make use of the new Thordarson 6L6 transformers for the input and output circuits.

The output transformer is designed for 2500, 5000, and 7000 ohm loads, and is capable of carrying the plate current of the modulated amplifier. The entire audio portion is built on a 7 x 17 inch, crackle-finished chassis, 2 inches deep, and has a metal cane style cover. The power supplies—there are two of them, one for the power stage and another for the three amplifier stages—are mounted on a similar chassis. A cage was not employed here, but would undoubtedly improve its appearance.

Separate Power-Supplies Used

The photographs show the complete unit ready to couple to the R.F. amplifier with the power supply sitting on the top of the speech equipment. The other two photographs show close-ups of both the speech and the power-supply portions. Due to the rather heavy current requirements of the power-stage and extra good regulation being necessary, separate power-supplies were used. The

The 6L6 tube, which is fast making history, is featured in this new *modulator* using all metal tubes. It has an output of better than 50 watts, and it will fully modulate an R.F. amplifier with 100 watts input.

one delivers 400 volts at 250 mills (ma.) and has only to serve the plates of the 6L6's. Another power-supply, delivering 250 volts, supplies the plate voltages for the three low-power stages and screen-voltage for the 6L6's. The screen voltage was taken from the low voltage power-supply in order to obtain perfect regulation and maintain the screen voltage constant during current swings of the power stage.

The transformers available would not permit a single 6.3 volt winding to feed all of the heaters and, therefore, as the diagram shows, the heaters were split up, some being run off the low-voltage power-supply, and some from the high-voltage power-supply. This is not at all inconvenient because the windings are already present on the transformer and are taken care of in the plug arrangement. In the rear of the speech unit we have two sockets which are receptacles for the power-supply leads and from the power-supply unit there are two cables with plugs attached to fit the sockets. In the high-voltage supply, we used an 83 rectifier and an 80 in the low-voltage power-supply. If the 83 causes a *hash* in the receiver, merely substitute it with an 83V which is a special vacuum tube, with regulation nearly as good as the 83. The 83 proved slightly more satisfactory when high output power-levels were desired because of its superior regulation.

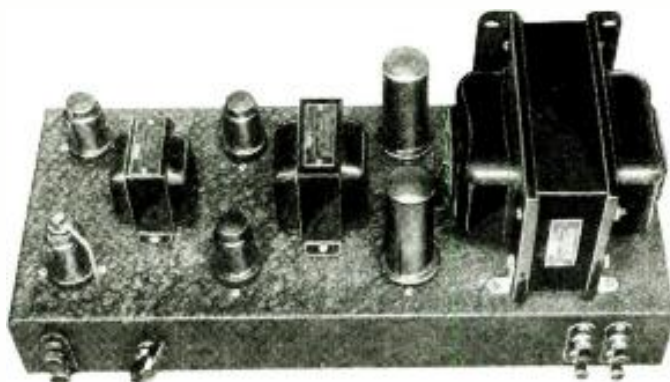

The speech or audio part of the modulating equipment.

"Gain-Control" and Bias Arrangements

Good equipment must be used in the construction of the power-supply and the modulator, because poor regulation can *not* be tolerated, otherwise you will have serious distortion and low-power output. The *gain-control* is incorporated in the grid circuit of the second speech amplifier. This is a 500,000 ohm potentiometer and usually has to

be turned on about 60 per cent for comfortable speaking into the microphone.

Plenty of circuit-isolating resistors and condensers are incorporated in the speech-amplifiers and are absolutely necessary wherever shown in order to obtain maximum stability.

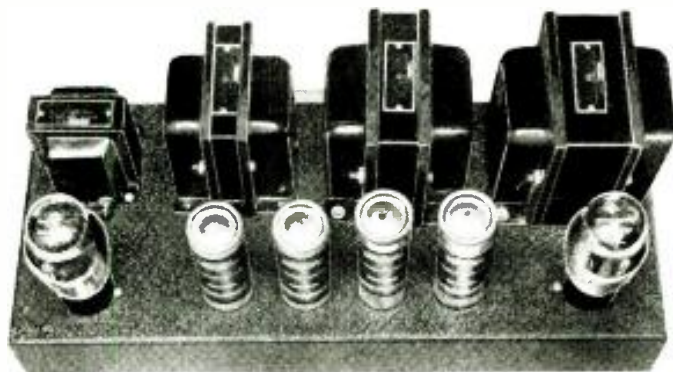

Right — The two power-supplies combined in one unit, which are used for the 6L6 modulator.

Described by
Its Designer—
Art Gregor

The 6L6 stage may be operated with automatic bias or fixed bias. The battery bias, or fixed bias arrangement, permits slightly greater power output. Although this grid voltage might have been obtained from the low-voltage power-supply, a separate battery was used. The small variety work well because of the low voltage requirements and also due to the very slight amount of grid current that flows during peak power-outputs, which has very little effect upon a good battery. Automatic bias is used throughout the rest of the modulator in the conventional manner.

Both the grid leads of the two speech-amplifier tubes are shielded with regular shielding braid. This was found necessary in order to reduce hum pickup and also possible feed-back. Under operating conditions, the amplifier, as we said before, gave over 50 watts audio, and the quality is extremely good. In fact, many who have heard it "over the air" claim that it sounds as good as anything they have heard and equivalent to "broadcast" quality.

There is absolutely no noise in the amplifier itself when using a crystal microphone, and not the slightest trace of hum—which also makes for better quality.

There are two types of output transformers available for the 6L6's. One is shown in this particular modulator, and

Parts List for
Modulator

AEROVOX

- 1—5 meg. resistor
- 1—3500 ohm resistor
- 1—50,000 ohm resistor
- 1—200,000 ohm resistor
- 1—100,000 ohm resistor
- 1—2,500 ohm resistor
- 1—10,000 ohm resistor
- 1—500 ohm resistor
- (The above resistors are all 1/2 watt)
- 1—20,000 ohm voltage divider
- 1—15,000 ohm voltage divider

ELECTRAD

- 1—5 meg. potentiometer
- 2—4 mf. condensers, 100 volt
- 2—2 mf. condensers, 400 volt
- 5—8 mf. condensers, 600 volt
- 1—.1 mf. by-pass condenser.

Name on Request

THORDARSON

- T1—Thordarson, T-5739
- T2—Thordarson, T-8459
- T3—Thordarson, T-8470
- T4—Thordarson, T-7550
- T5—Thordarson, T-7551
- T6—Thordarson, T-7064
- T7—Thordarson, R196

BUD

- 2—7 x 17 x 2 1/2 inch chassis, with bottom plates and one cane type cage, black crackle finish. Bud.
- 6—Bakelite wafer sockets, octal. Bud.

RCA

- 1—6F5 tube, RCA Radiotron
- 3—6C5 tubes, RCA Radiotron
- 2—6L6 tubes, RCA Radiotron
- 1—83 tube, RCA Radiotron
- 1—80 tube, RCA Radiotron

ASTATIC

- 1—crystal microphone, D-104

another which has low-impedance outputs ranging up to 500 ohms. It has been found desirable in many cases to use an "output" transformer with a 500-ohm output secondary and coupled to the modulated amplifier through a 500-ohm transmission line. Although this requires another transformer for matching the 500-ohm line into the modulated amplifier, it eliminates "feed-back" difficulties in that the modulator may be operated at quite a distance from the R.F. amplifier, and thus there will be little chance of R.F. getting into the modulating equipment. Of course, if care is used in setting up the apparatus, no R.F. should be present in the audio system. But one of the best ways of getting around this possible evil is to use the above method and employ a 500-ohm line between the modulator and the modulated amplifier.

This voice amplifier or modulator can be used for other purposes than a "Ham" transmitter. In view of the fact that it is a well designed and very stable amplifier, it may be used for many other purposes than that originally intended, and it is particularly efficient—thanks to the use of the new 6L6 type metal tubes. If you have not already read the article by the author describing how to build the "Beam Tube-3 Transmitter" utilizing two of the new 6L6 beam tubes, you would do well to look up this article in the August issue of *Short Wave Craft*. Complete circuit details and all the constants are given. The 5-meter MOPA transmitter, using two of the 6L6 tubes, described in full detail in the September issue, is also worthy of your study.

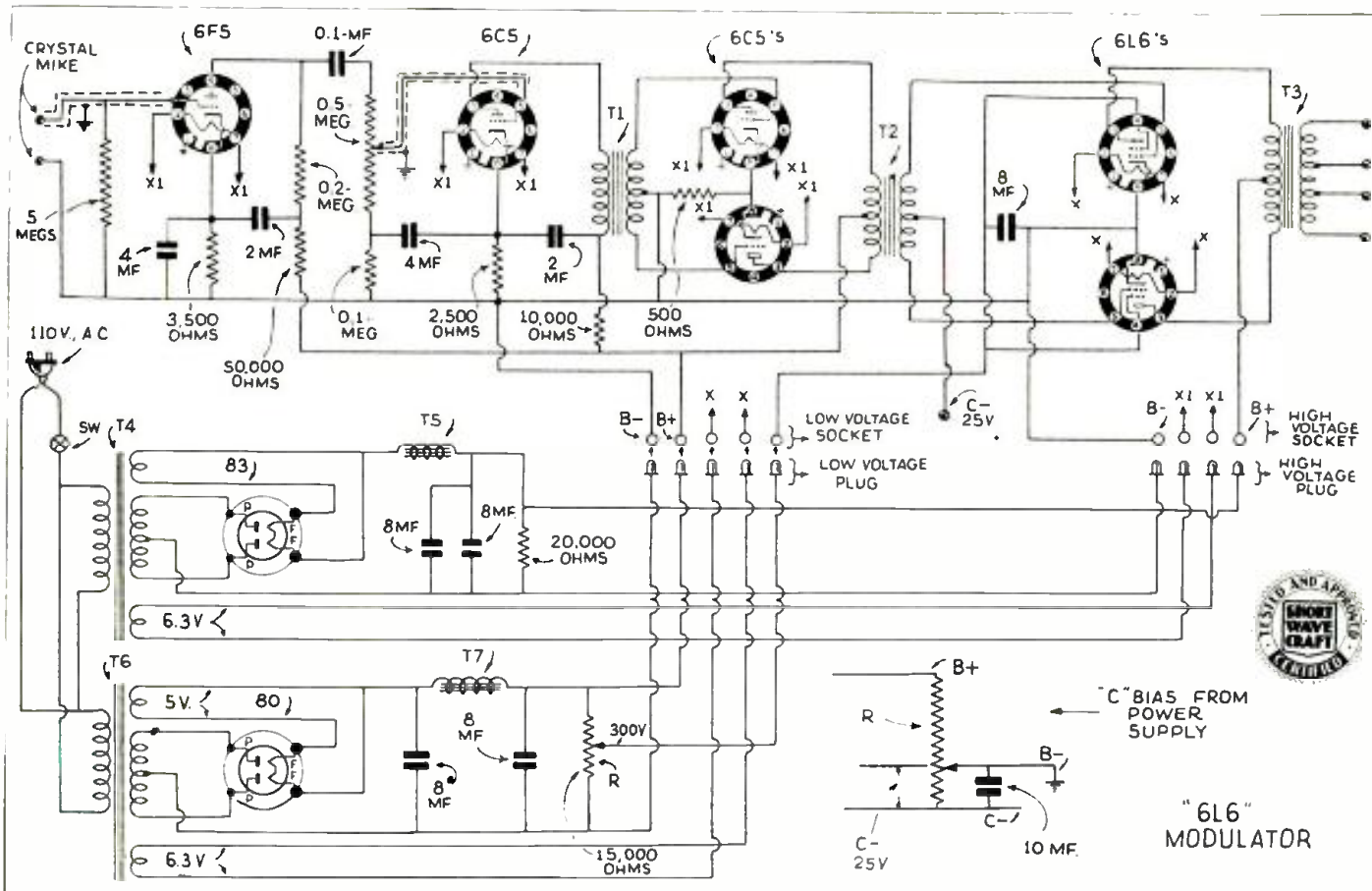

Diagram of the complete modulator and power-supplies.



All the paraphernalia—the MacKey, heavy-duty Eveready batteries, and transmitter. Just hook it up and go places!

Rural and Emergency



TRANS-

● THE transmitter described in this article is intended for two purposes. *First* as an emergency transmitter and *second*, for the "boys" who live in rural districts where the more modern conveniences such as electricity is not available. The recent floods, which will be remembered for a long time to come, illustrate the need for a good "emergency" battery-operated transmitter. It is our firm conviction that every Ham should have some sort of transmitter which could be put into use at a moment's notice.

Of course the transmitter we have reference to must necessarily be of the *flea-power* variety. One does not readily agree with the idea of keeping constantly on hand a bank of batteries capable of operating a more or less powerful transmitter—this would be a costly and foolish idea. But, 135 to 180 volts of "B" batteries can be found in nearly every Ham shack. Even if we had to go out and buy the batteries, just for the purpose of having them on hand to operate this transmitter, it would seem advisable and would represent a cost of only a few cents per month, based on a life of one year for the batteries. This is for "emergency" operation. For regular service as a *rural* transmitter of course the life of the batteries will depend upon the amount of service they are called upon to render. *Good batteries are cheapest in the long run!*

Choice of Tubes a Problem

It was quite a problem, choosing the tubes for this transmitter. It required high efficiency and economy, together with simplicity. No one wishes to put a lot of time and money into an auxiliary transmitter. The tubes finally chosen are the type 38. These will stand up better than the 2-volt line of tubes, although the "A" battery requirements are somewhat greater. The next problem—should we choose a MOPA or a *self-excited* rig? The MOPA idea was decided upon, in order to permit a certain amount of flexibility, which cannot be found in the other type. The next question—should it be *crystal-controlled*? There are quite a few angles to the problem, but it was decided that practically every Ham owns at least one crystal, and there was no reason for not employing it. There is no question but that it simplifies things considerably. Another reason is—should the regular transmitter go "dead" and the auxiliary rig be called into service by using the same crystal, our fellow Ham will find us on the *same* frequency, and will not have to *hunt for us!* Hunting for a weak signal in the

Many of our readers have requested that we publish an article describing a battery-operated "rural" transmitter; one that can also be used for "emergency" purposes by the regular "Ham," so here it is! This transmitter has been "tested on the air" and proved entirely satisfactory for the purpose for which it was designed. The "Ham" who has a large transmitter will find this an excellent auxiliary, while the rural chap needs a battery-operated affair and will be quite thrilled by its performance.

overcrowded bands is no cinch! And we are almost certain that the signal from this "rig" will be far weaker than that of the regular transmitter.

External Feed-back Employed

Referring to the circuit we see that it is conventional in nearly all respects. It consists of a 38 pentode oscillator in a feed-back circuit. This is not suitable for frequency-doubling in the oscillator stage. The 38 is so well shielded internally, that it was necessary to employ external feed-back from the plate to grid circuits in order to bring about stable and strong oscillation. This is done by soldering a wire to the grid and wrapping the other insulated end around the plate tank lead. Two or three wraps is sufficient.

Should anyone wish to employ the well-known *tritet* circuit in order that the transmitter may be operated on two bands with one crystal, it is only necessary to incorporate another condenser and a small coil in the cathode circuit. We have shown in the diagram how this may be done. By bending one end plate of the condenser, we can switch from one circuit to the other. When doubling with the *tritet* circuit the feed-back due to the grid-to-plate coupling wire is unnecessary and should not be used.

No Neutralizing Necessary

The amplifier tube operates as a screen-grid pentode and thus eliminates the necessity for neutralizing, further simplifying the transmitter. The screen-voltage on the oscillator and amplifier is the same as the plate voltage. The amplifier is coupled to the oscillator through a small .0001

mf. fixed condenser. Link-coupling might have been used with two separate tuned circuits, but the added complication did not seem to warrant its use. The grid of the amplifier is returned through a 2.5 mh. R.F. choke and a 10,000 ohm resistor.

In the plate circuit of the amplifier we find similar values to those of the oscillator. A 200 mmf. condenser is used for tuning and a plug-in coil for convenient band-changing. It was decided that in this transmitter the plug-in coils should be used, because one never knows what band we may have to operate on, especially in case of an *emergency*.

Arrangement of Apparatus

The entire transmitter is mounted on a 7½"x10½" wooden base, with most of the wires below the board. Re-

ferring to the top view, we find on the left the oscillator tube with the crystal behind it, the tuning condenser in front of it, and the plug-in coil on the right-hand side of it. The remaining tube, condenser, and coil are for the amplifier circuit. The 0 to 25 ma. meter serves to indicate plate current and aid in tuning. The underneath view shows the by-pass condensers and the grid resistor for the amplifier. A short length of No. 12 tinned bus-bar wire was used as a *master "ground"* connection and to it all by-pass condensers are connected.

Operation is extremely simply; you merely adjust the oscillator condenser until a *dip* is obtainable in the plate current of the amplifier by rotating the amplifier tuning condenser. A switching arrangement might be incorporated for changing the meter from the amplifier back to the oscillator plate circuit. However, it would not seem necessary, inasmuch as the amplifier plate current served

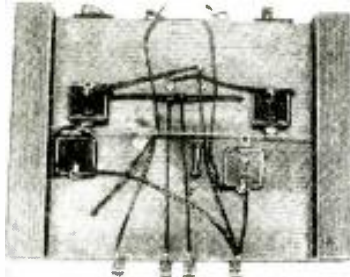

Bottom view of transmitter.

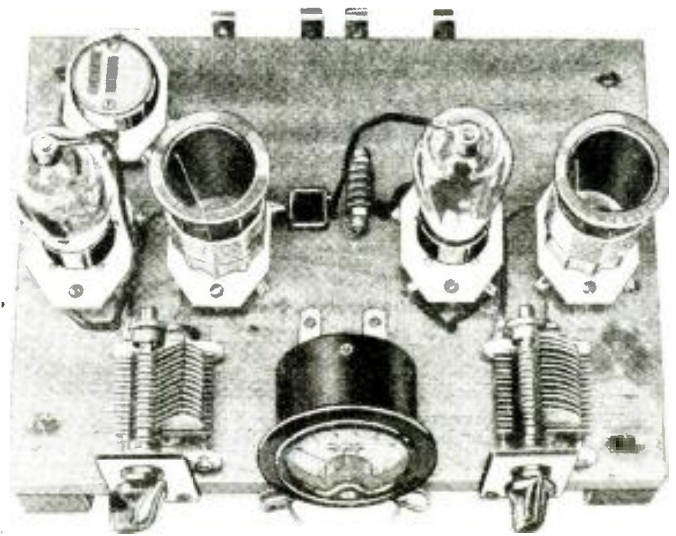

Close-up of the top view, showing how the parts are mounted.

MITTER

By George W. Shuart, W2AMN

as an indication as to whether or not the oscillator was working and just how strong.

The transmitter was tried with various voltages from 90 to 250. Naturally, the 250 volts applied to the plates and screens gave best results, although with 135 volts it was possible to get out on the 80-meter band with a fairly respectable signal.

Actual Tests "On the Air" Satisfactory

We contacted one station in New England some 75 or 100 miles distant and received an R6 report, the first time the transmitter was put on the air! Other QSO's proved that inputs as low as one to two watts performed remarkably.

It is quite important in an extremely low-powered transmitter of this type, to have the antenna properly adjusted,

because wasting power is "suicide" in this case—especially when you start off with only a few watts input!

Although coil data is given for the 80-meter band, this transmitter may be operated on 40 and 20-meters by employing suitable crystals. For instance, the new 20-meter crystal should make this transmitter entirely practicable on the 20-meter band.

Parts List

HAMMARLUND

- 3-5 prong Isolantite sockets.
- 2-4 prong Isolantite sockets.
- 2-200 mmf. midget tuning condensers.
- 2-2.5 mhr.f. chokes.
- 2-4-prong coil forms.

AEROVOX

- 2-10,000 ohm, 1 watt resistors.
- 2-.01 mf. by-pass condensers.
- 3-.002 mf. mica condensers.

TRIPLETT

- 1-0-25 ma. small meter.

BILLEY

- 1-80-meter crystal.

EVEREADY

- 3 or preferably 4-heavy duty 45-volt "B" Layer-built batteries.
- 4-No. 6 dry cells.

RCA RADIOTRONS

- 2-type 38 receiving tubes.
- Coil data: OSC. and AMP. for 80 meters. 16 turns No. 18 wire on 1 1/2" dia. form; winding spaced to length of 1 3/8 inches.

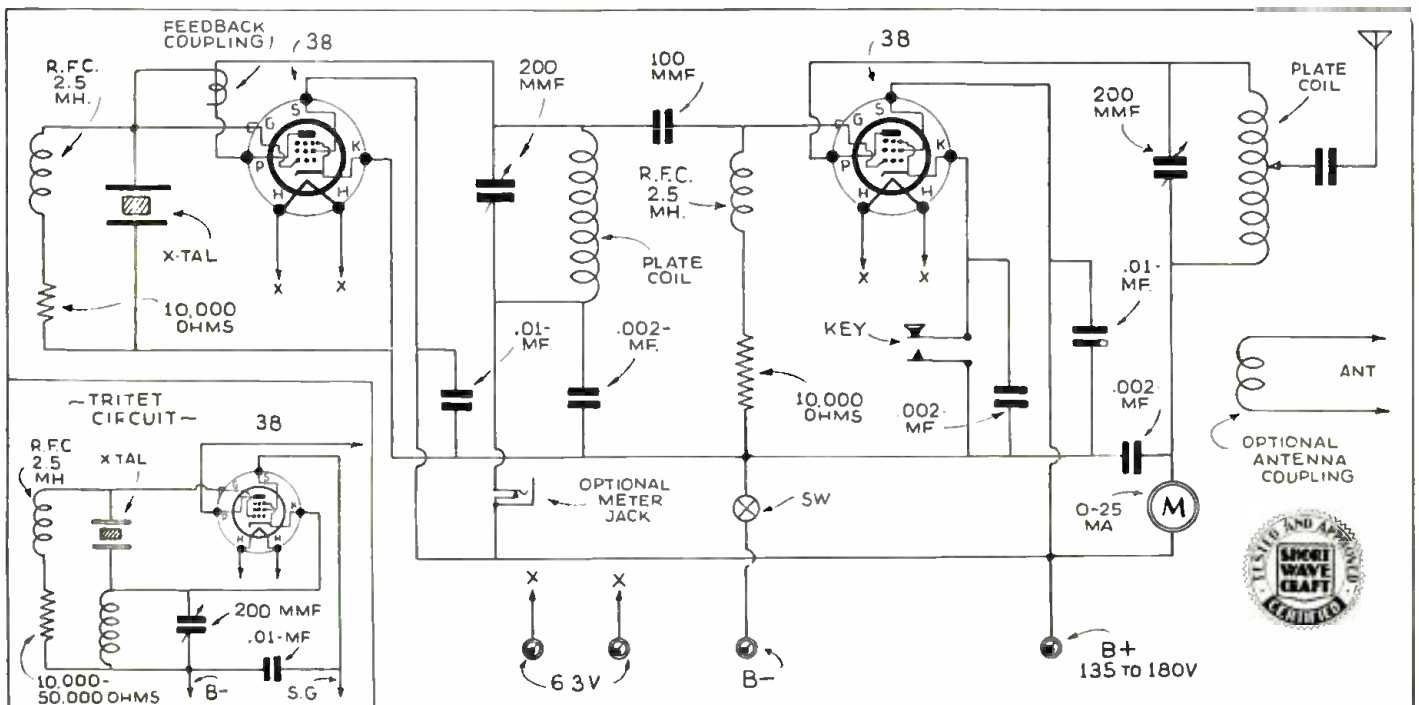

Schematic diagram of the "rural" and "emergency" transmitter using type 38 "receiver" tubes.



A METAL TUBE U.H.F.

● MANY of our readers are familiar with the now quite popular resistance-coupled, ultra-high frequency superheterodyne. Many questions have been asked about this type of receiver and among the most prominent, was whether or not *metal* tubes could be used to an advantage. The writer constructed the receiver shown in the photograph for the express purpose of trying out these tubes and comparing it with other receivers. We endeavor to keep this set as simple as possible, not including some of the fancier frills which may be added to almost any receiver.

There is apparently one distinct advantage in the use of *metal* tubes, and that is in the thorough shielding. It is possible, due to their small size and the fact that they require no shields, to make the set very compact and still not crowded to the point where operating efficiency would be sacrificed. Conventional metal tubes were used in the I.F. and A.F. portions. We mention this because in the detector we used one of the newer type which have an Isolantite insulated grid connection; this will be discussed later.

Simplicity and Low Cost Features

The outstanding advantage of a receiver of this type, of course, is in the simplicity of its construction and its relatively low cost. One building it is almost sure to obtain excellent results, if the few hints given in this article are followed. One need not worry about the delicate task of aligning I.F. transformers or similar adjustments.

The principle of the receiver is one of the oldest; in fact, this was one of the first types of superheterodyne receivers

A very neat and compact metal-tube, resistance-coupled superhet for 5-meter amateur reception is here described by Mr. Shuart. As shown the receiver is extremely simple to build and get working, and is about as sensitive as any of the present-day designs. For those interested in *experimental television*, as pointed out in this article, this set may serve as a forerunner in getting started in what we believe to be a fascinating era of amateur and experimental television.

used. The oscillating first detector works on the autodyne principle, with a very low frequency I.F. amplifier, which has a relatively wide band width. The range of the I.F. amplifier, in the neighborhood of 10 to 100 kc., means that the first detector may be tuned anywhere between 10 and 100 kc. either side of the signal

frequency and still permit reception. Or, looking at it from the other side, the incoming signal may swing from 10 to 100 kc. and still come through the I.F. amplifier with relatively good quality. This feature is what has made it exceptionally valuable in the ultra high frequency amateur bands, where modulated oscillators are employed in the transmitters.

Television Reception Possible

A receiver of this type may also serve as a forerunner for any one who is desirous of experimenting with *television reception* now that we have at least two stations in the *ultra-high frequency* region broadcasting television signals, RCA Empire State Transmitter (in New York City) and Don Lee Station in Los Angeles.

Getting back to the *first detector*, we will find that when it is tuned approximately to the transmitter frequency, we will hear a whistling sound, much the same as that we hear with the average regenerating detector which is in an oscillating condition. This means that the difference between the frequency of the transmitter and receiver is low enough to come within the audible range and the amplifier is acting as an *audio frequency* amplifier, rather than an R.F. amplifier. Somewhere between this audio frequency whistle and

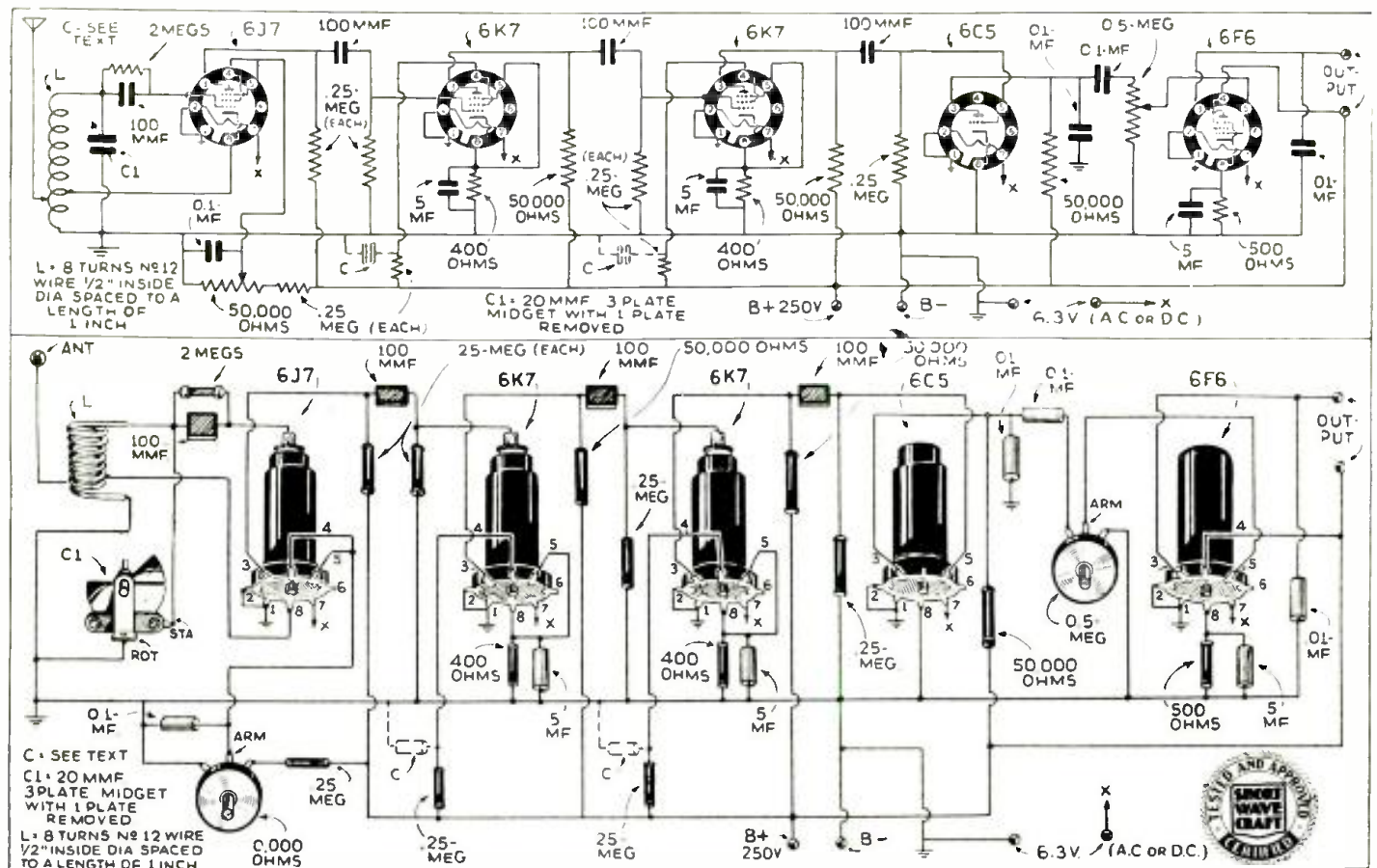

Schematic and physical diagrams of the 5-metal tube superhet for the ultra short waves.

Superhet

By George W. Shuart, W2AMN

the upper limits the amplifier works as an R.F. or I.F. amplifier. We hesitate to designate the line of demarcation and leave it go with the statement that when the detector is tuned about 20 to 50 kc. on either side of the incoming signal, the maximum sensitivity is brought about and the receiver works as a *superheterodyne*.

Tube Line-up

Referring to the diagram we see that a 6J7 is used as the first detector; 6K7's as the first and second I.F. amplifiers; a 6C5 as a grid-leak second detector; and a 6F6 pentode audio amplifier.

On the average 5-meter signal the receiver will supply enough power to a loudspeaker to make it *more than uncomfortable* for the listener and for this reason an audio gain control is incorporated in the output stage. It is surprising the tremendous wallop obtainable with this very simple set! The 6J7 detector, as mentioned before, is one having Isolantite insulation around the grid cap, while the conventional 6J7 with the standard phenolic insulation will give very good results; a 6J7 having the Isolantite insulation proved quite superior, inasmuch as the regeneration control did not have to be advanced anywhere near as far, which meant that there were less losses in the grid circuit.

Sensitivity

The over-all increase in sensitivity was quickly noticed by all who witnessed the comparison of the two tubes. Probably by the time this appears in print, the 6J7 will be available with an Isolantite base also. However, we do not look forward to any advantage with it in this particular circuit.

Regeneration and oscillation is brought about in the first stage by tapping the cathode on to the grid coil, approximately two turns from the "B" negative side. From this stage we go into the first I.F. unit which is coupled to the 6J7 by two 1/4 meg. resistors and a .0001 mf. condenser. The 1/4 meg. resistor in the plate of the 6J7 proved to be superior to the usual 10,000 to 50,000 ohm resistor, although the *selectivity* of the receiver was apparently *increased* with the higher value. The 6K7 I.F.



The 5-meter superhet pulling in "Ham" phone stations.

amplifiers employ 50,000 ohm plate resistors and 1/4 meg. grid resistors. The other values are clearly shown in the diagram.

The original receiver, using glass tubes, required higher screen voltage and permitted by-pass condensers at points marked "C" in the diagram. However, when the metal tubes were installed, best results were obtained with 1/4 meg. resistance in the screen leads and no by-pass condensers. Experiments showed that .001 mf. condensers in position "C" increased the overall volume of the signal, but with it the tube noises also; thus the net result was just about the same as without the condensers.

However, different constructional layouts might prove to demand changes in this part of the circuit, and we recommend that the builder try condensers up to .1 mf. for *by-passing* screen leads.

The receiver is housed in a 5x9 1/2 x 6 inch metal cabinet and the chassis is 9x4x1 1/2. The photos show top and bottom views and indicate how the parts are placed.

Antenna

Best results were obtained with the antenna connected directly on to the grid coil, at about 1/2 turn from the B negative end. No *dead-spots* were noticed with this rather loose coupling, but should they occur with other types of antennas, it is suggested that a 35 mmf. condenser be connected in series with the antenna.

Parts List

- HAMMARLUND**
1- 20 mmf. midget condenser (one plate removed).
- CORNELL-DUBILIER**
4- .0001 mf. mica condensers.
3- 5 mf. electrolytic condensers.
2- .01 mf. condensers.
2- .1 mf. condensers.
- AEROVOX**
7- 1/4 meg., 1/2 watt resistors.
1- 2 meg., 1/2 watt resistor.
3- 50,000 ohm, 1/2 watt resistors.
2- 400 ohm resistors.
- ELECTRAD**
1- 50,000 ohm potentiometer.
1- 500,000 ohm potentiometer.
- NATIONAL COMPANY**
1- vernier dial.
- MISCELLANEOUS**
5- laminated octal sockets.
1 set of tubes, see diagram and text.



Rear view, showing general construction.

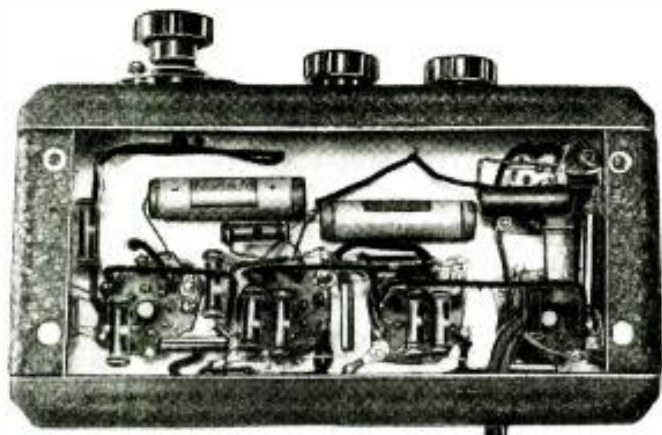

Note the neat wiring and placement of resistors.



This Doerle 6-tube receiver has a very pleasing as well as professional appearance.

DOERLE 6-Tube "Band-Spread" S-W Receiver

By Guy Stokely, E. E.

This 6-tube receiver is one that hundreds of "Fans" have asked data on—forms a complete set, with its own "built-in" rectifier and filter. It features band-spread, powerful audio amplifier, and T.R.F. as well as stage-aligning trimmer.

The Doerle 6-tube receiver from the rear.



● EMBODYING all of those features so essential to the proper reception of those "far-away" and "hard-to-get" stations, the Doerle has proved to be extremely popular among the "old-timers" as well as the "beginner." Europe—Asia—Australia—South America—Africa, roar in with tremendous volume and remarkable regularity at the proper time of day or night for the frequency in question. Only the dyed-in-the-wool "fan" who has experienced this thrill can fully appreciate the significance of this statement.

The high order of sensitivity and selectivity of which this receiver is capable, is due in large part to a careful choice of circuit constants and a well-ordered layout of its components. A simple and highly efficient circuit, free from all "frills" which do not actually contribute to the performance of the entire receiver, is used. No useless gadgets are employed; each and every part has a very definite function to perform and has been carefully chosen so as to do its work in the most efficient manner possible.

Either a standard or doublet type of antenna may be used. Because of their noise-reducing properties, a doublet is preferred by many short-wave fans, and is an absolute necessity in many locations. In the average locality, however, it may be better to use the common single-wire "inverted-L" type of antenna working against ground. However, regardless of the type of antenna preferred by the individual this receiver is designed to accommodate it.

Highly efficient plug-in coils, the most efficient method of band changing ever developed, are incorporated in the design. By their use it is possible to cover all wavelengths from 8½ to 200 meters in only 4 steps. An additional set of coils enables the regular broadcast band (200-550 meters) to be covered. Extra coils extending the range up through

2,000 meters may also be used. All coils are wound with silver-plated wire in order to avoid "skin effect losses" which become of considerable importance at the higher frequencies. Special forms of bakelite, ribbed so as to remove most of the dielectric from the field of the coil are specified. The careful choice of the proper "form factor" for these coils, and by paying careful attention to the proportions assigned to the coupling winding on each coil, results in an order of efficiency which in the opinion of the author is essential in order to obtain the maximum possible gain from a good short-wave receiver.

Band-Spread Dial Used

Another extremely attractive feature of this Doerle 6-tube receiver is the use of a specially designed band-spread type of dial. This dial is positively free from all traces of backlash and enables one to readily (Continued on page 430)

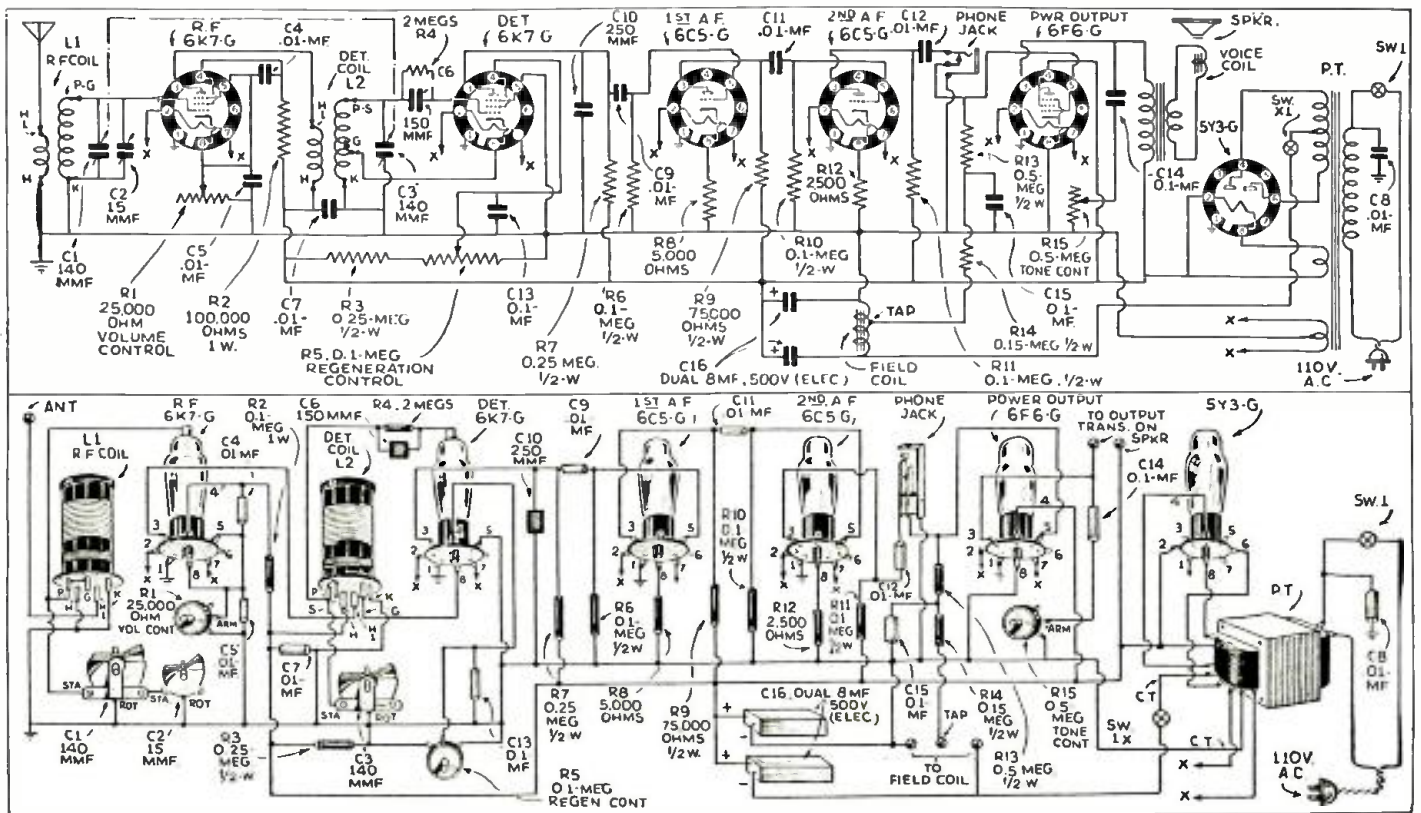

The hookup of this 6-tube "band-spread" receiver is quite simple; the short-wave enthusiast interested in European as well as domestic "broadcast" reception, should find no difficulty in building one of these sets.

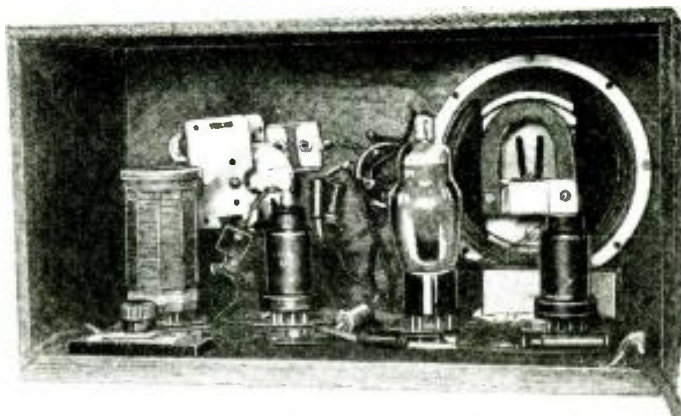

Front and rear views of the Jr. "Space-Explorer." One of its features is the wooden cabinet, which gives an improved sound quality. The outside of the wooden case is finished with the new crystal lacquer.

Junior "SPACE-EXPLORER"

All-Wave 4-

By H. G. Cisin, M.E.

● REALLY excellent performance, unusually attractive appearance and amazingly low cost are the triple features destined to win thousands of loyal friends for the Junior "Space-Explorer" All-Wave 4.

In spite of its Spartan simplicity, this well-designed receiver has "what it takes" to bring in the distant "foreign" short-wave stations. With "professional" case, the Space-Explorer tunes in not only European stations, but also Australian and Asiatic broadcasts.

The performance of a radio receiver depends first upon circuit design and then upon the type of tubes utilized. Many "trick" circuits have come and gone, but the "time-tried" standard regenerative detector used in this receiver remains unsurpassed in its ability to reach out and bring in stations from the far-off corners of the world. At the risk of "gilding the lily" certain refinements have been added. However, these are not experiments, but worthwhile fea-

tures. As far as the metal tubes are concerned, there is no longer any question as to their desirability. From the standpoint of adequate shielding alone, without considering their other obvious advantages, metal tubes have earned

This 4-tube receiver will be found of low construction cost and at the same time it will afford loudspeaker reception of both "Foreign" and Domestic short-wave stations. Plug-in coils are used to cover the various S-W bands. This set works on 110 volts A.C. or D.C. and may be used on 220 volts with a special adapter. A "Ballast" resistor tube is a new feature.

their place in the sun, particularly as regards short-wave reception.

In the Junior Space-Explorer, a 6J7 tube is used as the regenerative detector. Both the suppressor grid and the cathode are grounded directly to the common negative, without the use of

bias resistors. A 1-meg. resistor in the screen circuit reduces the screen voltage to approximately one-third that of the plate. While the screen voltage is not highly critical, it has been found that best results are obtained by maintaining this definite ratio between plate and screen. Naturally, it is necessary to use a by-pass condenser between the screen-grid and the negative return.

Regeneration Control

Several methods of *regeneration control* are available, but the one employed seems to give smoothest results in this particular type of circuit. It consists of a potentiometer shunted across the tickler, with the center arm of the potentiometer connected to one side of a .0005 mf. fixed condenser. The other side of the condenser goes to the common negative.

The Junior Space-Explorer uses a system of *overlapping* plug-in coils. (Continued on page 432)

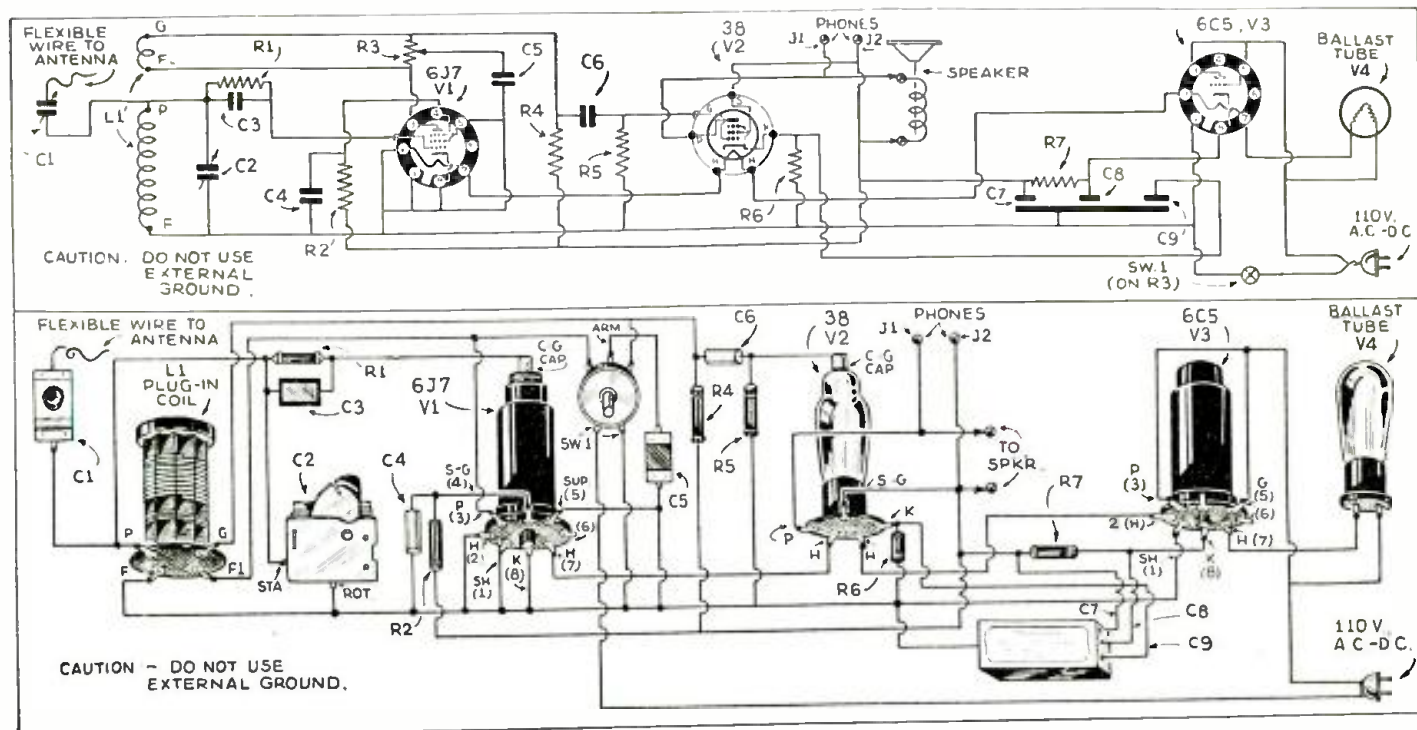

Wiring diagram for the Jr. "Space-Explorer"

SHORT WAVES and Our Readers Forum. LONG RAVES

Dr. Sherman's Dandy "Ham" Rig Wins Prize



Dr. C. A. Sherman, of Kansas City, Mo., has built one of the neatest short-wave transmitting and receiving stations that the editors have ever seen—it all fits into a beautiful hardwood secretary desk. He wins one year's subscription to "Short Wave Craft."

Editor, SHORT WAVE CRAFT:

Herewith a picture of my "rig"—a rather unusual layout. I had to build it a little different, as our living room is the only available space I had, and the XYL wouldn't stand for the ordinary "haywire layout."

The cabinet is an all walnut veneer; the removable front hides and protects the transmitter from dust accumulations and mal-adjustments by curious meddlers and visitors, and complies with the F.C.C. regulations regarding "lock and key" protection, in the absence of the operator.

The entire "rig" is a "bread-board" layout. Each unit is instantly removable from the front, leads and power supplies being coupled by plug-in sockets.

Below are all the power-packs. On the shelf, or table top, as you will, is an A.C.R. No. 136 "Magic Eye," modulation unit, switch controls, and key. On first shelf above, is the speech input, amplifier and Class B modulator. On the middle shelf, a 59 crystal-controlled oscillator, and 841 buffer or doubler.

The final amplifier is a pair of 10s in push-pull, modulated by 10s, Class B. Keying is done in the buffer stage.

While no unusual claims are made for D.X., many hours of pleasure are had both on CW and fone.

C. A. Sherman, M.D., W9SVC,
3300 Virginia Avenue,
Kansas City, Missouri.

(Congratulations, Doc. on your very fine idea of building the complete "Ham" transmitting and receiving equipment into a desk. We hope that other readers with similar ideas will take a photo of their "rig" and send it along.—Editor)

A Greenville, S. C., Amateur "Hot-Spot"!

Editor, SHORT WAVE CRAFT:

I am a constant reader of your F.B. magazine and have watched with interest the pictures of the amateur radio transmitters and believe I have a chance to win one of your free subscriptions. So here is the dope on the "rig."

46 crystal oscillator, 46 first buffer, (2) 210's second buffer and 511 final amplifier, 200 watts input speech amp. and modulator as follows: double-button mike, 56 first speech, 56 second speech, (2) 45's "drivers" driving (2) 210's in Class "B", using 5 separate power-supplies and battery bias on the Class "B" 210's. Work on 160 meter phone only. I have worked all districts in U. S. and VE 1-3-5; worked 37 states. The meter at top is R.F. meter in antenna (0-5 amp.). My set shows 2 amp. and current most of the time. The others are milliammeters, except the one at bottom, which is a filament voltmeter. I shall be glad to answer any questions about the "rig." to any reader of your magazine.

Roy W. Bomar, W4CWT,
14 A St. Woodside,
Greenville, S.C.

(Well, Roy, it looks as though you had been "around the world," judging by the grand display of QSL cards. That husky transmitter certainly looks like business. Congrats. on the excellent results you have obtained with this "rig" and don't forget that the editors are interested in obtaining descriptions and constructional data on any new transmitter or receiver stunts that you develop.—Editor)

(Continued on page 449)



W4CWT—operated by Roy W. Bomar, of Greenville, S.C., cuts a wide swath in the ether waves when he cuts loose down in his "neck of the woods."

SHORT WAVE . SCOUTS

THIRTY-SECOND TROPHY CUP

Presented to

SHORT WAVE SCOUT
MILBURNE O. SHARPE
P. O. Box 25,
Knoxville, Tenn.

For his contribution toward the
advancement of the art of Radio
by



Magazine

32nd TROPHY WINNER 72 Stations—51 Foreign

● AGAIN we take pleasure in presenting another of our Short Wave Scout Trophies. This is the thirty-second to be awarded, and it goes to Mr. Milburne Sharpe. Congratulations, Milburne, and don't forget to send us a picture of yourself and that Trophy.

Mr. Sharpe informs us that he uses a G.E. M-81 receiver with ordinary horizontal antenna approximately 85 feet long, and all stations were heard on the loudspeaker. The stations were received during the latter part of 1935, so in reading the list you will find that the present wavelengths and call letters of some of the stations may differ considerably. A correct list appears elsewhere in the magazine.

We might offer a suggestion to the other contestants that they have their entries in order. For instance, the cards should be stacked in the same order that they appear on the list. This greatly facilitates checking by the judges and naturally saves considerable time.

List of Verified American Stations (Mr. Sharpe's "Log")

Call	Frequency	Location
W1XAL	6040	Boston, Mass.
W1XB	6040	Miami, Florida.
W3XAL	6060	Cincinnati, Ohio.
W3XAU	6060	Philadelphia, Pa.
W9XAA	6080	Chicago, Ill.

Honorable Mention

Dwight L. Brown, Mt. Sterling,
Ky.

Frank Fontella, P.O.B. 178, Wil-
merding, Pa.

● ON this page is illustrated the handsome trophy which was designed by one of New York's leading silversmiths. It is made of metal throughout, except the base, which is made of handsome black Bakelite. The metal itself is quadruple silver-plated, in the usual manner of all trophies today.

It is a most imposing piece of work, and stands from tip to base 22½". The diameter of the base is 7¾". The diameter of the globe is 5¼". The work throughout is first-class, and no money has been spared in its execution. It will enhance any home, and will be admired by everyone who sees it.

The trophy will be awarded every month, and the winner will be announced in the following issue of SHORT WAVE CRAFT. The winner's name will be hand engraved on the trophy.

The purpose of this contest is to advance the art of radio by "logging" as many short-wave phone stations, amateurs excluded, in a period not exceeding 30 days, as possible by any one contestant. The trophy will be awarded to that SHORT WAVE SCOUT who has logged the greatest number of short-wave stations during any 30-day period.

W3XAL—6100—Bound Brook, N.J.
W9XF—6100—Chicago, Ill.
W2NE—6120—New York, N.Y.
W8XK—6140—Pittsburgh, Pa.
W2XAF—9530—Schenectady, N.Y.
W1XK—9570—Springfield, Mass.
W3XAU—9590—Philadelphia, Pa.
W1XAL—11790—Boston, Mass.
W2NE—11830—New York, N.Y.
W8XK—11870—Pittsburgh, Pa.
W8XK—15210—Pittsburgh, Pa.
W2NE—15270—New York, N.Y.
W2XAD—15330—Schenectady, N.Y.
W3XAL—16300—Bound Brook, N.J.
W2NE—17760—New York, N.Y.
W3XAL—17780—Bound Brook, N.J.

List of Verified "Foreign" Stations
YV1ORSC—5720—San Cristobal, Venezuela.
YV2RC—5800—Caracas, Venezuela.
TG2X—5940—Guatemala City, Guatemala.
H1X—5980—Santo Domingo, D. R.
XEFT—6000—Mexico, D. F.

(Continued on page 444)



Trophy Contest Entry Rules

● THE rules for entries in the SHORT WAVE SCOUT Trophy Contest have been amended and 50 per cent of your list of stations submitted must be "foreign." The trophy will be awarded to the SHORT WAVE SCOUT who has logged the greatest number of short-wave stations during any 30 day period; (he must have at least 50 per cent "foreign" stations). This period need not be for the immediate month preceding the closing date. The complete list of rules appeared in the September 1935 issue.

In the event of a tie between two or more contestants, each logging the same number of stations (each accompanied by the required minimum of 50 per cent "foreigns") the judges will award a similar trophy to each contestant so tying. Each list of stations heard and submitted in the contest must be sworn to before a Notary Public and testify to the fact that the list of stations heard were "logged" over a given 30 day period, that reception was verified and that the contestant personally listened to the station announcements as given in the list.

Only commercial "phone," Experimental or Broadcast stations should be entered in your list, no "amateur transmitters" or "commercial code" stations. This contest will close every month on

the 25th day of the month, by which time all entries must be in the editors' hands in New York City. Entries received after this date will be held over for the next month's contest. The next contest will close in New York City October 25th; any entries received after that date will be held over till the next month.

The winner each month will be the person sending in the greatest number of verifications. Unverified stations should not be sent in, as they will not count in the selection of the winner. At least 50 percent of the verifications sent in by each listener must be for stations located outside of the country in which he resides! In other words, if the contestant lives in the United States at least 50 percent of his "veries" must be from stations outside of the United States. Letters or cards which do not specifically verify reception, such as those sent by the Daventry stations and, also by commercial telephone stations, will not be accepted as verifications. Only letters or cards which "specifically" verify reception of a "given station," on a given wave length and on a given day, will be accepted! In other words it is useless to send in cards from commercial telephone stations or the Daventry stations, which state that specific verifications will not be given. Therefore do not put such

stations on your list for entry in the trophy contest!

SHORT WAVE SCOUTS are allowed the use of any receiving set, from a one-tuber up to one of sixteen tubes or upwards, if they so desire.

When sending in entries, note the following few simple instructions: Type your list, or write in ink, pencilled matter is not allowed. Send verification cards, letters and the list all in one package, either by mail or by express prepaid; do not split up the package. Verification cards and letters will be returned, at the end of the contest, to their owners; the expense to be borne by SHORT WAVE CRAFT magazine.

In order to have uniformity of the entries, when writing or typing your list, observe the following routine: USE A SINGLE LINE FOR EACH STATION; type or write the entries IN THE FOLLOWING ORDER: Station call letters; frequency station transmits at; schedule of transmission, if known (all time should be reduced to Eastern Standard which is five hours behind Greenwich Meridian Time); name of station, city, country; identification signal if any. Sign your name at the bottom of the list and furthermore state the type of set used by you to receive these stations. State total No. stations.

\$5.00 Prize

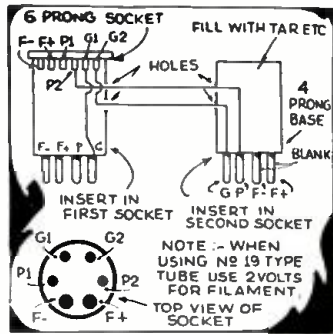

USING 19 IN PLACE OF TWO 30'S

In the drawing I have endeavored to clearly show just how I used a single 19 to replace two type 30 tubes without changing any wiring in the receiver. A 1-prong tube base is cemented to a socket into which the 19 sits. This serves as one triode connector. Then two wires are connected to another 4-prong tube base connecting the grid and plates to the grid and plates of the second triode. The second socket is plugged into the audio stage of the receiver.—Edwin Stollhorn

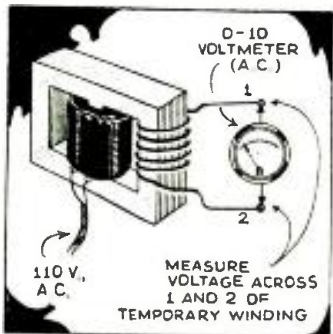

REVAMPING POWER TRANSFORMER

To determine the number of turns required for a new winding, use a small A.C. voltmeter of about 0-110 volts. Wind about 15 or 20 turns of thin enameled or cotton-covered wire around one leg of the core, as shown, and count the turns carefully as they are put on. Now connect the primary of the transformer to the 110-volt A.C. line and with the A.C. voltmeter measure as accurately as possible the voltage developed in the temporary 15 or 20 turn winding. Suppose our winding consists of 21 turns and the voltage as read on the voltmeter is 7, then the turns per volt would be 3. Thus for a 63 volt winding in the same place on the transformer core, approximately 18.9 turns will be required.—Harry D. Hooton, W8KFX.

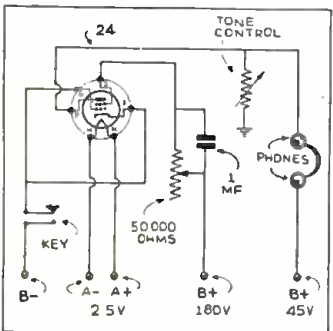

CHANGING PITCH OF A.F. OSCILLATOR

The use of a single audio frequency tone when practicing code is extremely tiresome to say the least. A simple method of varying the tone of the code oscillator over two octaves of the musical scale is illustrated. The exact tone will depend upon the voltage applied across the potentiometer and the adjustment of the arm. The pitch increases at low voltage and decreases when the arm is turned toward the positive side of the circuit. A 45-volt "B" battery and a good quality transformer will give 1000 cycle note when the control is "full-on." This arrangement can be used with either an ordinary hand-key or a code machine. A calibrated dial plate under the knob will enable any desired tone to be selected at will.—Harry D. Hooton, W8KFX.

\$5.00 FOR BEST SHORT-WAVE KINK

The Editor will award a five dollar prize each month for the best short-wave kink submitted by our readers. All other kinks accepted and published will be awarded eight months' subscription to **SHORT WAVE CRAFT**. Look over these "kinks" and they will give you some idea of what the editors are looking for. Send a typewritten or ink description, with sketch, of your favorite short-wave kink to the "Kink" Editor, **SHORT WAVE CRAFT**.

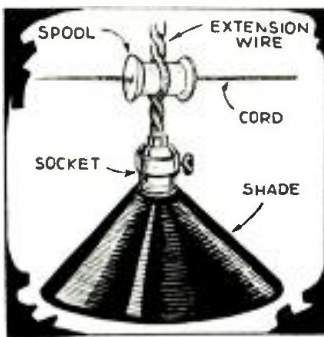

LIGHT WHERE WANTED

If you wish to have light over your entire work-bench and you can only burn one light, you will find the following kink very practical. All that is needed is a piece of cord, which is fastened between two walls over the work-bench, a spool which is slipped over this cord, and an extension wire which is fastened to the spool. This illustration will give you some idea of how it is constructed.—Carl Schwarzenburg.

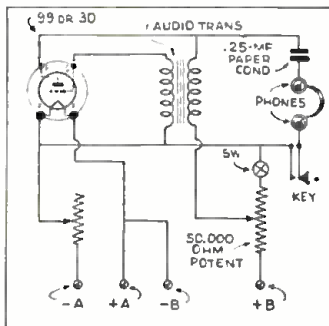

F.B. OSCILLATOR

Herewith you will find the circuit of a code practice oscillator which I have used for quite some time. The tube used is a type 24 with the grid and cathode tied together. Different tubes may have to be tried. I used a "B" eliminator on this oscillator, with about 45 volts on the plate and 180 volts on the screen. The tone control is a 7 point octave control or a fixed condenser may be used; with the control the pitch can be varied over a wide range. The control in the screen voltage is not absolutely necessary, but I used it to control the volume.—William Felix.

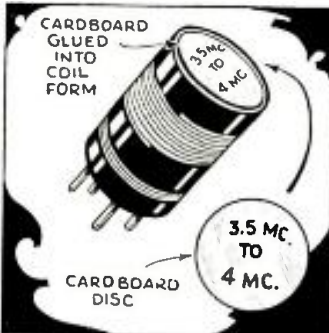

COIL MARKER

The kink which I am submitting comes in handy with tube-base coils which are not color-coded. Simply cut a circular piece of white cardboard to fit the inside diameter of the coil, or slightly larger. Print the frequency range on the cardboard and glue it to the coil, as indicated in the drawing.—L. Rodney Bradshaw.

HOME-MADE HIGH-FREQUENCY BUZZER

A high-frequency buzzer can be easily made from an old earphone and a few cheap parts. The earphone is mounted in a vertical position with a very heavy magnet. A contact point is soldered to the diaphragm. The other contact point is mounted on another bracket in front of the earphone. Directly behind this bracket is another, in which there is a slit to adjust the pitch of the buzzer. To insure the best results the buzzer must be made very substantially and the diaphragm kept as light as possible. The tone closely resembles that of the buzzers on the market.—Gerald Huntzinger.

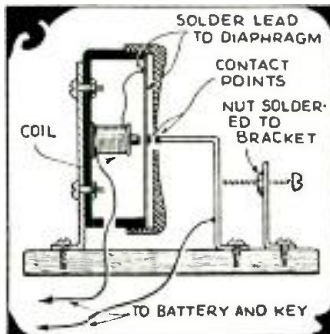

ASHTRAY HOLDER

I believe this kink will solve the amateurs' problem as far as holders for soldering irons are concerned. I just rest my iron on an ashtray as the illustration indicates. Needless to say a glass or metal ashtray should be used; composition rubber and other inflammable materials will not stand the heat of the iron.—Sanford Hershfield.

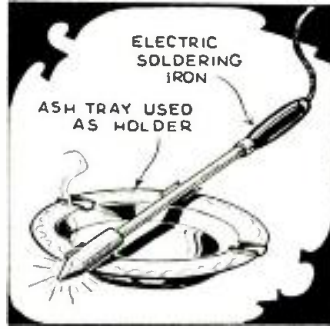

BIAS FOR TRANSMITTER

By adding an extra tube and filter system to the power-supply, a source of "D" bias can be had and still retain full-wave rectification for the "B" supply. Resistor "R" will determine the amount of "C" voltage.—Morton Benson

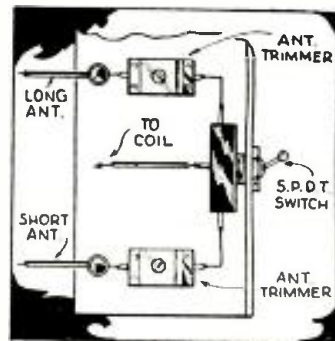
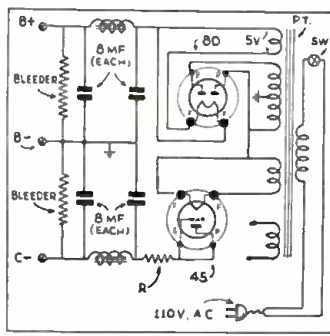

ANTENNA SWITCH

I have found this system to be one of the best when using two antennas of different lengths. The switch is a single-pole, double-throw toggle type. The center connection goes to where the antenna condenser is connected on your set. When tuning, switch on one antenna and tune its condenser for best reception, and then do likewise with the other antenna.

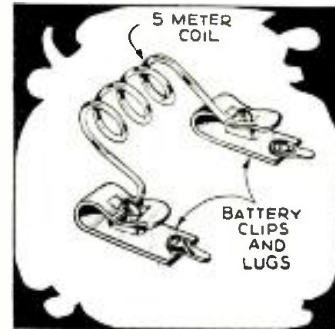

A GOOD IDEA

By this method differing types of coils may be used, simply by clipping them into the battery clips. This same method can be used for the split type coils by employing four clips.—Edward Mineika, W9WIG.

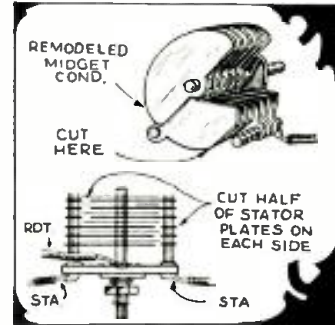

SPLITTING CONDENSER STATOR

I am submitting a kink which shows how to make a split stator trimmer condenser from single bearing midget 8-W condensers. Simply alter the stator plates by cutting as indicated in the illustration, and grounding the rotor plate.—Bruce Long.

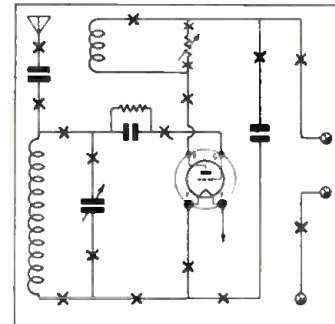

KINK FOR SET-BUILDERS

Many beginners in building radio sets misplace wires or leave them out entirely. It is this difficulty which has prompted me to submit the "Kink" which is illustrated. By drawing the diagram on a piece of paper and checking the lines as you place the wires in their proper places, this trouble will be very easily overcome.—Alfred Steekleviz.

WHAT'S NEW In Short-Wave Apparatus

A New Sargent Receiver for the Ham and Fan



Above—Front and chassis views of the Sargent Model 11 T.R.F. receiver, available in ranges as great as 9.5 to 20,000 meters. (No. 584)

The new Model 11 receiver here described is available in different frequency ranges and employs a time-tried circuit. Band-spread is provided and the A.C. model has its own hum-less power supply built in.

and keeps the coil shield currents almost entirely out of the receiver chassis. A glance at the rear and bottom views of the receiver will show the care with which it is built.

Tuning Ranges—The set is available in three tuning ranges, as follows:

Amateur Tuning Range—9.5 to 550 meters.

Marine Tuning Range—9.5 to 3750 meters.

Universal Tuning Range—9.5 to 20,000 meters.

The receiver is exactly the same for all tuning ranges, the only difference being in the coil units.

The Coil Units—Until recently it was impossible to build a receiver having the wave coverage of the Marine or Universal model without introducing serious losses on the short wave band. Difficulties in the way of doing this have been completely overcome and it is now possible to build a multi-band coil unit having losses as low as or lower than those of any other type. The Model 11 uses separate coils for each wave-band. Antenna coil, secondary, and tickler have all been designed for best results on each band.

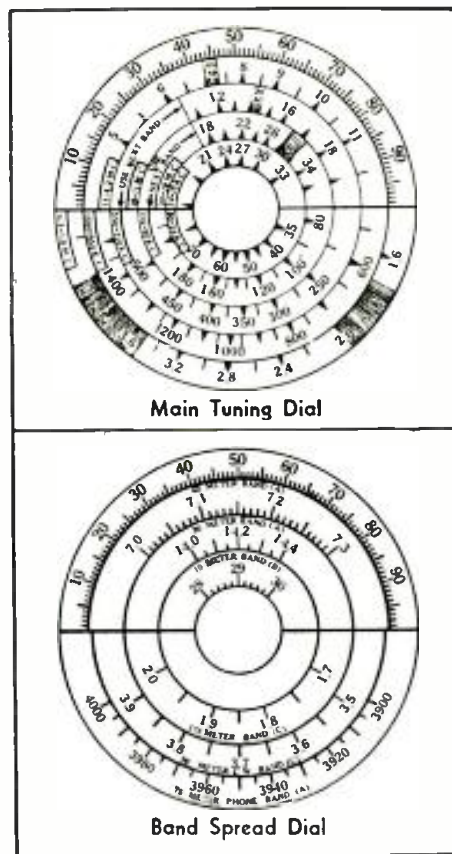

Typical band-spread dial and also main tuning dial calibrations as supplied with the Model 11 Sargent receiver. These sets are available to cover the amateur, marine, or universal tuning range.

Coils are well spaced and the wave-change switch has an extra section to short-circuit (Continued on page 425)

● THE tuned radio frequency receiver, by virtue of years of satisfactory service under all conditions, occupies a place of highest esteem among radio operators. Many commercial and experienced amateur radiomen regard it as an old friend, and these in particular will be glad to know of the new standard of performance established by the Model 11 Sargent—a new achievement in a tuned radio frequency receiver. The extreme sensitivity, quietness and flexibility for which these receivers are noted have been retained in full, and the selectivity has been improved to such a point that it is matched only by the most expensive multi-tube receivers of other types. For code work in particular, it has a world-wide range on short waves, and the operator who understands the handling of regeneration can also pick up many short-wave broadcast stations that are lost in the background noise on many larger sets. Due to its all-wave coverage it is excellent for reception of time-signals, weather reports, ship and airplane beacons, ship-to-shore telegraph, broadcast band, police, airplane and amateur signals of all kinds.

Selectivity—The unusual selectivity may be attributed to the scrupulous care that has been used in the design and layout. Plenty of space has been allotted for all parts. Everything is placed in position to assure shortest leads and most efficient wiring. Coil units, both short and long wave, are completely shielded within themselves, and are then set into the receiver on studs arranged to give a six-point grounding to the receiver chassis. This is mechanically sufficient for firm anchorage

been completely overcome and it is now possible to build a multi-band coil unit having losses as low as or lower than those of any other type. The Model 11 uses separate coils for each wave-band. Antenna coil, secondary, and tickler have all been designed for best results on each band.

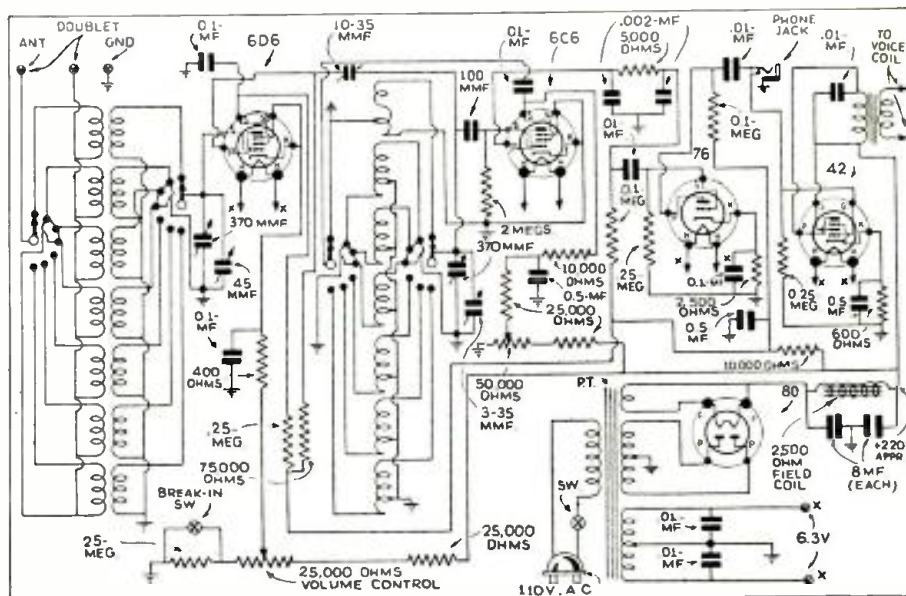

Circuit of the Sargent Model 11 A.C. receiver, with power-supply built in.

Names and addresses of manufacturers of apparatus described on this and following pages furnished upon receipt of post-card request: mention No. of article.

New Apparatus for the "Ham"



Tuning Wand, H67.



Neutralizing Condenser, H66.

NEUTRALIZING CONDENSER—H66

● A NEW neutralizing condenser for high-powered amplifiers has recently been introduced by the National Company. This is a heavy-duty affair especially designed for neutralizing the HK-345 and 852 or

single high-voltage tubes. It is constructed of 3/16 in. aluminum plates with rounded and polished edges and these are insulated from the mounting foot by glazed Isolantite columns. The upper arm and mounting base are ridged cast aluminum. The adjustment screw is slotted and may be locked in any position by tightening a small lock-screw.

TUNING WAND—H67

● AMATEURS who have been using a neon bulb for aiding in tuning transmitters will find this instrument exceptionally useful. It's a long tubular affair filled with a special gas. At each end of the glass tube specially constructed end-pieces permit determining whether or not the tuning circuit of your transmitter requires more or less inductance, merely by placing the wand near the coil. When placed relatively near an R.F. field, the entire tube does not light up. It starts from one end and the length of the glow increases as the R.F. field increases in intensity. Its action is quite similar to the familiar neon tuning indicators formerly employed with broadcast sets, although there are no metal electrodes used in this instrument.

MODULATION MONITOR—H68

● HERE is something every phone "Ham" should own—a "modulation monitor," manufactured by Triplett. It indicates the actual percentage of modulation on a direct-reading scale in a range of from 40 to 120 per cent. All readings are in peaks. The meter is the well-known dual type Triplett. One shows the carrier level and also may be used for checking carrier shift during modulation. These instruments are calibrated at the factory and no further adjustment or calibration is necessary. Its neat construction is illustrated in the photo.



Modulation Monitor, H68.

TRANSMITTING INDUCTANCE—H69

● THE transmitting inductance shown in the photograph is designed for maximum efficiency and durability. It is constructed of heavy enameled copper-clad steel wire and supported by narrow celluloid strips. The one shown in the photo is a 20-meter inductance with a two-turn link coil which is easily slid over the outside where link-coupling is desired. So mechanically rigid is this inductance (Continued on page 422)



Transmitting Inductance, H69.



This view clearly shows the excellent design and professional appearance of the "Ultra Sky rider." (No. 575)

De-Luxe U. H. F. Receiver

● WITH the constantly increasing development of the ultra high frequency spectrum and the certain possibility that it will continue to increase, makes the new "Ultra Sky rider," an exceptionally interesting and valuable receiver. This new Hallcrafters product is designed along ultra modern lines. It covers a frequency range of from 6 mc. to 78 mc. in four steps. It is designed along the lines of the standard communication type receiver and embodies all of the latest outstanding developments. Among these are: Metal tubes, a *Noise Silencer* and a special Band-Switching arrangement, eliminating the use of plug-in coils. Sensitivity in microvolts at 50 milliwatts output with a 30 per cent modulated 400 cycle signal is exceptionally attractive. For instance, at 6 mc. it is .566; at 11 mc. .323; at 18 mc. .24; at 30 mc. .366; at 68 mc. .333; and at 78 mc. 1.866.

Manufacturers claim these values are the result made of a test by a disinterested laboratory.

The tube line-up is as follows: 6K7, R.F. amplifier; 6C5, oscillator; 6L7, first detector; 6K6, first I.F.; 6L7, second I.F.; 6J7, noise silencer amplifier; 6Q7, noise silencer and first A.F.; 6R7, second detector and beat oscillator; 6F6, power amplifier; and (Continued on page 437)

New Code-Teaching Machine Works from Lamp Socket

● CONTRARY to popular conception, learning to send is much more difficult than learning to receive. Sending is very similar to handwriting. Every sender has his own peculiar characteristics, just as in handwriting.

This new *master teleplex* is a real contribution to those aspiring to master the code, because it offers a practical way whereby one can see and hear his own signals. If some of the "Hams" who are now on the air could use this instrument for a few minutes, they would realize what poor "fists" they have. No operator can send perfect signals. Granting that to be a fact, it is still astounding how many "hams," who confidently and honestly believe they are good senders (not merely good senders, but fine senders!) would be gravely disappointed if they could hear some of their own signals.

The new code-teaching machine works from any A.C. lamp socket. An electric motor pulls the special wax paper tape through the perforating die. When the sending key is closed a hole is perforated in the tape, and when the sending key is opened another hole is punched in the tape. As the tape is moving forward at a steady rate of speed the distance between the two holes will represent exactly the duration of time the key was held closed. Two holes are perforated in the tape for each dot and two holes for each dash. After the tape has been recorded it is again passed through the instrument, the first hole will cause the oscillator circuit to be closed, so that the signal is heard in the headset; the second hole will open the oscillator circuit. Thus it will be seen that the signals will be recorded and repeated back exactly as made.

After the tape has been recorded, the signals are, of course,

(Continued on page 437)



New A.C. operated Teleplex code-teaching machine. (No. 576)

"AIR-TESTING" the NC-100

By H. Edwin Ruth, 3rd, W2GYL



Here we see Ed. Ruth, W2GYL, tuning in a DX station on the new National "NC-100X." Mr. Ruth was snapped by Stanley P. McMinn, W2WD, Sec'y of the Garden City Radio Club.

The Editors of *Short Wave Craft* have been much impressed by the claims made for the three new National receivers, which are characterized as the NC-100 series. In order to avoid drawing any conclusions of our own, regarding the performance of these units, we have, in this instance asked Mr. Edwin Ruth, to prepare a report on his findings. Mr. Ruth is one of the most successful Radio Servicemen on Long Island and is Chairman of the Technical Committee of the now-famous Garden City Radio Club.

● FOR the past several years I have had an opportunity to use various types of modern radio receivers over long enough periods to become very thoroughly acquainted with the performance of most of the important units. At the time that the first descriptive matter concerning the NC-100 appeared, I was intrigued by the apparent high degree of engineering, both mechanical and electrical, which this new receiver was said to incorporate. At that time I was operating a National FBXA Receiver and National Preselctor. I had made quite a number of changes in both of these units, providing automatic volume control and audio tone control for the receiver itself as well as regeneration in the radio frequency unit.

From the descriptive matter which began to appear in radio publications as well as from advance information, secured from my local National dealer, it seemed to me that all of the desirable features, incorporated in my own receiver—and many more—were to be found

in this latest achievement of the National Company.

I have used and sold a number of these receivers since that time, and, therefore, my experience covers not only the NC-100 but also the NC-100X and the NC-100XS. The first, of

The accompanying reproduction of a page torn at random from Mr. Ruth's station log (W2GYL), made during the annual A.R.R.L. "DX" Contest, is worthy of attention. All the stations listed were heard (on NC-100X) during DAYLIGHT, and those with which actual "two-way contact" was made, are indicated by the numerals in the right-hand column. These numerals are special code numbers used during the contest for cross-checking purposes, to prevent erroneous reporting of stations which were not actually "worked."

course, is identical to the other two, except for the elimination of the Crystal Filter Circuit and the use of a different type of loud speaker. It has seemed to me that the overall performance, as far as the receiver's ability to pick up stations a long distance away and reproduce them with satisfaction, in my station is about the same for all three models. Of course an improvement in tone quality is found when the special high fidelity loud speaker is employed

A study of the charts shown at left, and also at right, indicate the generous amount of "handspread" which is provided for all services between 10 and 550 meters.

and this improvement is true on all models. On the other hand, the reproduction from the standard model is so much better than the reproduction from any other communications type receiver that we have used as to make the high fidelity speaker unnecessary, in our opinion. The simplicity with which we have been able to swing from one group of frequencies to another, without in any way introducing losses which have made it necessary to readjust the controlling units of the circuit, has appealed very strongly to us. Our transmitter is reasonably high-powered and we operate on several of the amateur bands. The

DATE	STATION CALLED	CALLER	TIME	MODE	RESULTS	REMARKS
AM						
9 17	CQ					
9 40	Z51M		36	5 7 9		
9 50	Z51M		"	5 7 9		
9 57	Z51M		"	5 7 9	5 6 9 10 95	AFRICA 444
10 06	CQ					
11 12	K4OH		36	5 7 9	5 8 9 11 40	PORTO RICO 175
P 12 10	XE1AA		42	5 7 9		
12 20	CP1AC		50	4 4 7		
12 23	H15X		39	5 9 9		
12 30	CP1AC		51	3 3 7		
P 2 37	G5KG		77	5 8 9	5 6 9 2 43	ENGLAND 777
2 44	YL2BB		85	5 7 8		
2 50	D46AD		98	5 9 9		
2 59	D40YL		67	5 7 9	5 7 9 3 10	GERMANY 111
3 13	PA0HT		69	5 7 6		
3 17	EA1AB		68	5 7 9	5 8 9 3 21	SPAIN 118
3 24	ON4NC		81	5 8 9		
3 32	OK2DP		74	5 6 8	5 7 9 3 43	CZECHOSLOVAKIA 777
3 44	PA0LF		73	5 7 7	5 6 9 3 47	HOLLAND 555
3 50	D4BIU		72	5 8 8		
3 55	EA4AD		89	5 9 9		
4 00	ON4NC		81	5 8 9	4 6 9 4 08	BELGIUM 444
4 11	G2KM		72	5 6 9	5 6 9 4 19	ENGLAND 321
4 28	SU5MK		82	5 6 9	5 6 9 4 35	EGYPT 593
5 05	FM8D		85	5 6 9		
5 18	CM2AD		78	5 9 9		
5 25	PA0WH		90	5 5 7	5 5 8 5 37	HOLLAND 138
6 20	K5AV		93	4 4 4		
6 25	FBXW		95	5 6 4	5 7 9 6 31	FRANCE 157
6 40	F8OK		71	5 6 9		
6 45	CK2AK		73	5 8 9	5 7 9 6 49	URUGUAY 337
6 55	FM8D		85	5 7 9	5 7 9 6 59	FRENCH MOROCCO 210
7 05	EA4AD		88	5 8 9		
7 10	EA4AD		"	"	5 7 9 7 16	SPAIN 485
7 17	VU3AT		81	4 5 9	5 6 9 7 27	INDIA 171



rapidity with which we can now switch from one band to another has proved to be a convenience which we thought would never be possible in a commercial type of communications receiver. Then, (Continued on page 438)

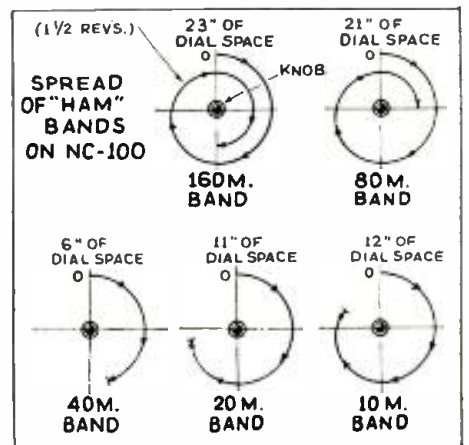

The "Ham" bands are well spread out, as shown.

New 6-Tube "Rack-Mounting" Set Has Many Features



Front view:—Note its professional appearance. (No. 573).

● THE receiver shown in the photograph is of the regenerative type and includes many novel features. It employs a tuned R.F. stage, a regenerative detector with a special compensating regeneration control, and three stages of audio amplification. In the R.F. stage we find a 6K7 inductively coupled to the 6K7 detector. In the detector circuit we find an arrangement somewhat out of the ordinary, in so far as the control and adjustment of regeneration is concerned.

The circuit is of the electron-coupled type, wherein the cathode is tapped on the grid coil. In order to make regeneration more constant over the tuning range of the grid circuit a special condenser is employed in the plate circuit and ganged with that of the grid circuit. The actual regeneration control is the variable resistor

denser and a switch. When the switch is closed, putting the condenser across the grid and "B" negative circuits, there is a tendency to attenuate the higher frequencies and thus reduce somewhat the general background noises. However, this arrangement only works when the speaker is being used and in no way affects operation during the use of headphones.

Referring to the diagram, one might be somewhat dismayed at the peculiar connections in the grid circuit of the R.F. stage. The coils are arranged in such a manner that if you are working

connected across the cathode portion of the grid coil.

The manufacturers claim that this unique method of controlling regeneration permits more stable operation and the regeneration control requires less attention by the operator.

In the diagram we see that a headphone jack is connected between the first two amplifier tubes which are 76's. This jack is so connected that when the earphones are plugged in, no signal is permitted to pass through the last two audio tubes. The 42 power pentode amplifier provides sufficient output to operate a dynamic speaker to full volume.

In the grid circuit of the pentode we find a .008 mf. condenser and a switch. When the switch is

closed, putting the condenser across the grid and "B" negative circuits, there is a tendency to attenuate the higher frequencies and thus reduce somewhat the general background noises. However, this arrangement only works when the speaker is being used and in no way affects operation during the use of headphones.

Looking at the photograph we find that separate dials are used for the R.F. and detector stages and are mounted on either side of the speaker, which is in the center of the panel. Below the speaker we find a chart of tuning curves for the various bands which this receiver covers.

The dials have a special vernier knob which means that for slow tuning one uses the knob; while in passing from one end of the scale to the other, it is only necessary to grasp the dial by its outer edges, thus saving considerable time.

These rack-mounting types of receivers are coming more and more into favor with the advanced short-wave listener.

This article has been prepared from data supplied by courtesy of Ace Radio Laboratories.

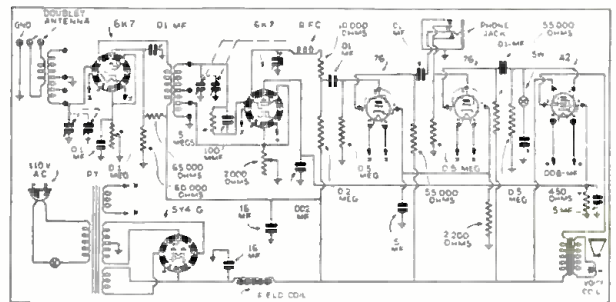

Diagram showing the values of the various parts.

New 18-Tube Receiver Has Range 4.5 to 2400 Meters

● THE new 1937 Midwest panel as used on their 18-tube, 6-band receiver, marks a new style in dials and escutcheons. The unusually large and beautifully colored dial is surrounded by a large chrome escutcheon in a new design motif, which moves sideways from the center. It contains all of the controls necessary in handling this set, which tunes from 4.5 meters to 2400 meters in 6 bands.

There are no external controls on the back of the receiver and no unnecessary motions are required. Wave-band selection is made by means of the stream-lined lever just below the center of the escutcheon. This lever controls all of the eight switches which connect the proper coils into their circuits, and adjusts the sensitivity of the I.F. to the proper value for every band. It also mechanically controls a band-indicating device which shows, at a glance, the band that is being tuned so that one is never lost or in doubt as to what to expect.

The extreme left-hand knob-like "housing" contains a Push-Button Silencer which is used to eliminate all extraneous noises while tuning between stations. The three actual control knobs are used for Volume Control, Dual Channel Audio Program Expander and Power Control Switch. All tuning is done by means of a very large central knob, which permits fast tuning between

stations and also final micro-metric adjustment on the station.

The Dual Channel Audio Program Expander is more than a tone control and is worthy of its name, inasmuch as it actually controls a dual-channel audio amplifier. This second, super-power audio channel selects and greatly amplifies the low frequency audio tones, which are quite impossible of reproduction by ordinary methods. These lower tones are brought back to their original power and vigor.

Thus, it restores to the music, the full measure of rhythm that is so beautiful in the original orchestration and so sadly lacking in the usual radio reproduction. The reproduction by the loud-speaker of this 18-tube dual-channel "bass expander," sets a new standard of tonal values, the manufacturers state. Some sets accentuate a few bass notes falsely and effect an artificial booming, barrel-like tone that is very unpleasant; all bass notes are equally amplified in this new dual channel super amplifier, it is claimed.

The final control brings a new development to radio, that has been sadly needed for a long time. It is a means of turning down the power consumption. It seems so unnecessary to use the full power of the electric lighting lines when only a soft musical background is desired for conversation, bridge games and other home activities. By means of a very clever arrangement of windings and switches, controlled by the final-control knob, the cost of operating the radio is cut to less than 50% of normal. This reduction in power consumption is accomplished without in any way decreasing the enjoyment to be secured from powerful stations, regardless of their locations.

The dial disc, itself, contains several radio innovations. As a companion for the Silencing Push-Button, a visual means of determining proper tuning is provided. (Continued on page 439)

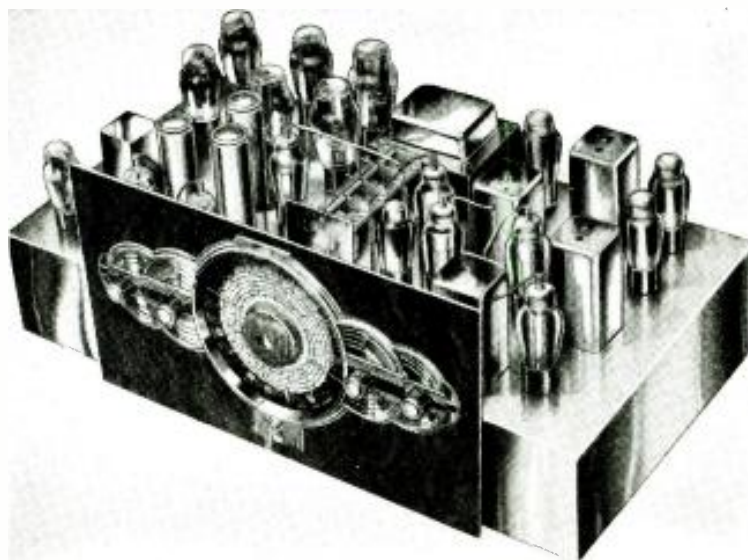

The new "Midwest" 18-Tube, 6-band Receiver. It tunes from 4.5 to 2400 meters! (No. 574)

Names and addresses of manufacturers of apparatus described on this and following pages furnished upon receipt of "post-card" request; mention No. of article.

Small-size Radio-Phonograph Set



Attractive radio-phonograph combination fitted with 5-tube A.C. superhet and covering the American, Foreign, and Police bands. (No. 579)

● THERE has been a demand for a small size combination radio and phonograph, and the one shown in the accompanying illustration fulfills these requirements in an up-to-date manner. It tunes in the short waves as well as the regular "broadcast" band.

The radio receiver incorporated in this set is a 5-tube A.C. superheterodyne, and domestic programs, police calls, and foreign programs can be tuned in. The set tunes in the following bands: 172-555 meters, and 40-136 meters. The set is designed for operation on 110-120 volt, 60 cycle A.C. circuits, and is also available with a special transformer for operation on 150 volt, 230, and 250 volt A.C. circuits, and frequencies of 25 or 60 cycles.

The dimensions of the cabinet are interesting—it stands only 16 inches high by 17 inches wide and is 14½ inches deep. The phonograph has an A.C. motor and is fitted with a high fidelity pickup. It will play 10 inch as well as 12 inch records. The volume control functions for both the phonograph and the radio set. The cabinet is made of figured striped Oriental and burl walnut in contrasting design.

The radio set is fitted with a tone control, new type micro-selector indirectly lighted dial, 6½ inch dynamic speaker, and has a power line noise filter. The net weight of the set is 34 pounds.

Our Information Bureau will gladly supply manufacturers' names and addresses of any items mentioned in *Short Wave Craft*. Please enclose stamped return envelope.

Condenser Bridge-Analyzer

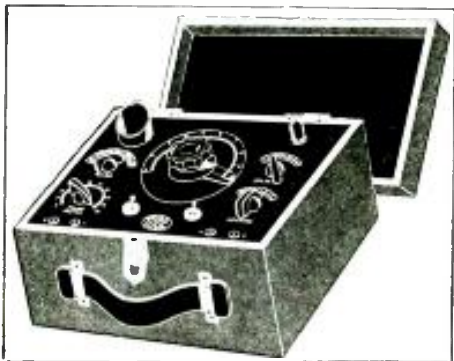

The latest A.C. bridge and condenser analyzer. (No. 578)

● AN a-c bridge and condenser analyzer combination for the radio serviceman and S-W experimenter has been announced

New Short-Wave Sets and Devices

by the Tobe Deutschmann Corporation, Canton, Mass. The particular features of the instrument are the points—that in addition to the usual dynamic tests for "shorts," "opens," and intermittent condenser conditions—power-factor can be read directly, and capacities measured with greater precision than on ordinary capacity meters. It also functions as a resistance-bridge. The instrument has a built-in neon tube for direct condenser check, with 6E5 electric eye "null-indicator" for bridge balance. The test set also uses one O1A tube. Resistance range: 1 ohm to 1 megohm. Capacity range 10 mmf. to 100 mf.

This article has been prepared from data supplied by courtesy of Tobe Deutschmann Corp.

The Lowest-Priced S-W Receiver

● MODERN research has resulted in the development of a really efficient line of radio receivers, which can be built by any-

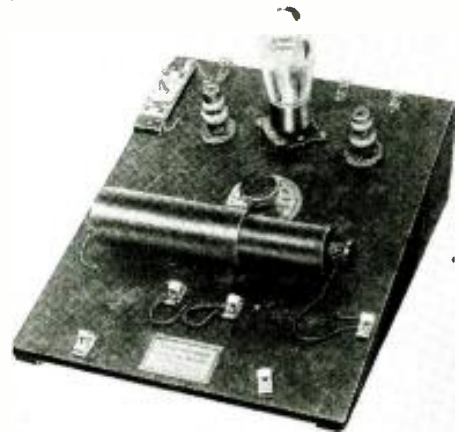

Appearance of low-cost, easily-built S-W 1-tube receiver. (No. 577)

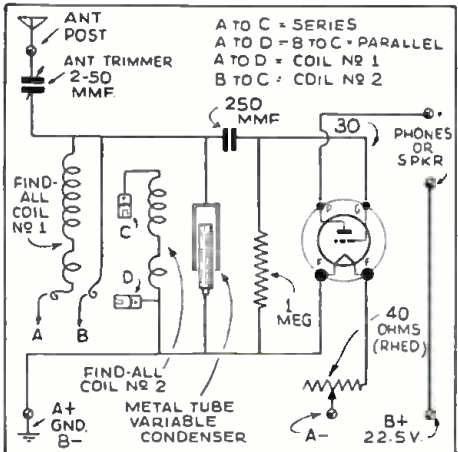

Diagram of the Air Scout Junior 1-tube receiver.

one at a cost in the neighborhood of one dollar, including the vacuum tube. These new sets have been designed by H. G. Cisin, M.E. Chief Engineer of the Allied Engineering Institute and inventor of the well-known a.c.-d.c. circuit.

The set illustrated is known as the Air Scout Junior. It was designed with the express purpose of bringing the benefits of radio within the reach of everyone. This radio is assembled on an attractive sloping panel, 8½" by 11", with earphone terminals at the front and battery terminals conveniently located at the rear. It uses a low-drain 30-type tube, requiring only one 22½-volt "B" battery and two flashlight cells for the "A" battery.

This receiver is equipped with two lat-

Head-phone Attachment—Fits Any Set

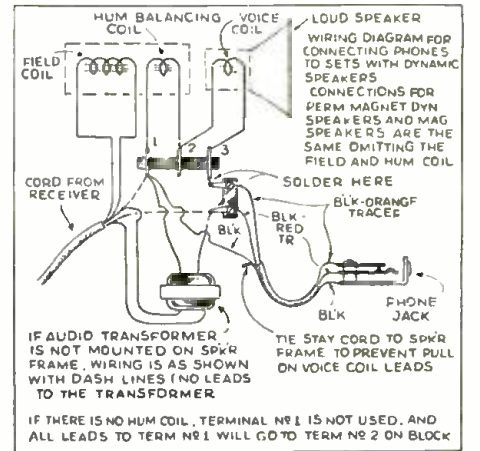

The simple attachment shown enables you to fit head-phones to practically any receiver. (No. 582)

● MANY short wave "Fans," and amateurs for that matter, have need for applying earphones to a receiver not already so equipped. Recently there was announced the introduction of a simple device which may be used to convert any set to earphone operation. The important part of the assembly is clearly shown in the photograph. Here we have switch which will permit either loud-speaker or phone operation, separately, or at the same time. If you wish to use earphones and not disturb other members of the family the speaker may be silenced by merely throwing a switch. It would seem that the "wee small hours" of the mornings would require an arrangement of this sort, if you are after some of those "DX" stations.

This article has been prepared from data supplied by courtesy of the C. F. Cannon Co.

NEW MULTI-WAVE COIL ASSEMBLY

● Short-wave "Fans" and amateurs interested in constructing all-wave receivers will find this new Meissner multi-wave, 5-band unit of exceptional utility. It is a 3 section affair, composed of coils and switches for the R.F. detector and oscillator stages of the superheterodyne. Five stages are used to cover a band of 42,500 kc. to 140 kc., and any of the bands may be dropped or eliminated at will. Separate coils are employed for every band. All leads are kept very short and the majority of the coils mount directly

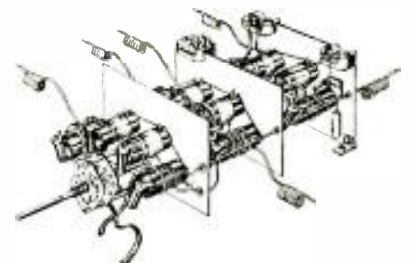

New Multi-wave Coil Assembly.

on the switch, with their terminal leads serving as the connection and mounting support.

Grounds or negative returns are not common, inasmuch as they are connected

THE RADIO AMATEUR

Conducted by Geo. W. Shuart

Radio Amateur Course

● IN this lesson of the *Course* we will consider various types of ultra high frequency transmitters, not including, of course, the well-known *transceiver*. Fundamental circuits of the more important and efficient transmitters are shown and will be discussed.

In Fig. 1. we have the unity-coupled circuit using two triodes in push-pull. Either two separate tubes may be employed or the dual triode tubes, such as the 53, 6A6, and others. For those desiring a compact oscillator circuit of simplicity this one is recommended. Its inherent stability is no better than the usual tuned oscillator, although it is more easily controlled and usually better results are obtained because no critical adjustment of grid circuit tuning is necessary.

The inductance consists of a fairly heavy piece of copper tubing, through which a finer insulated wire is run. The inside wire is the grid coil, while the copper tubing is in the plate circuit. It will be noticed that the grid of one triode enters the copper tubing at the plate end of the other triode. This is necessary to obtain a *feed-back*. In the center of the copper tubing opposite to the tubes the grid return lead is brought out. In a sketch in Fig. 1 we have shown just how this coil is constructed.

The antenna may be coupled to the plate coil at points "A", that is on either side of the "B" plus lead, or another single-turn "loop" the same size as the plate coil may be employed for antenna coupling.

In Fig. 2, we have the very popular *long-line* oscillator, sometimes called a linear oscillator. Here we have extended the tuned circuits by employing two heavy copper rods or pipes in each circuit. The tuning is accomplished by sliding the bars marked "S" either toward or away from the tubes, making the circuits shorter or longer. As they become shorter of course, they resonate at a higher frequency. Theoretically, these lines should be approximately $\frac{1}{4}$ wavelength long, but due to the internal capacities of the tubes and the inductance of the tube leads and connecting leads from the copper pipes to the tubes, the length of the line will be somewhat shorter than $\frac{1}{4}$ wavelength.

For the special ultra high frequency tube, such as the 800 or 304A and 304B, the lines will be longer than if 210's or 801's are employed. A good length would be somewhere around 46 inches. This would serve for any type of tube in the 5-meter band. Best results have been obtained when the spacing between the two rods is equal to the diameter of one of the rods. In other words, if $\frac{1}{2}$ inch rods are used the spacing between them would be $\frac{1}{2}$ inch. Complete information on this is shown in

FIFTEENTH LESSON U. H. F. Transmitters

Fig. 2. When operating on wavelengths shorter than 5 meters the lines of this system become uncomfortably short. In Fig. 3, we show the *open-end* line which theoretically at resonance would be $\frac{1}{2}$ wavelength long used in conjunction with a single tube. Here,

also, the line will be somewhat shorter than $\frac{1}{2}$ wavelength because of the losses introduced by the tube. The "B" plus and the grid lead are tapped on to the rods $\frac{1}{4}$ wavelength from the open end or the end opposite to the tube. This is the point marked "X" in the diagram and at which no R.F. voltage will appear. This system works exceptionally well on wavelengths as low as $1\frac{1}{2}$ meters and exceptionally well on $2\frac{1}{2}$ meters with the average present-day tube.

Special tubes, such as the new WE-316A will give more satisfactory results, of course, and may be employed in the *push-pull* arrangement of the same circuit shown in Fig. 4. While the oscillator circuits, already explained and shown in the diagrams, are efficient and have served the purpose for the past four or five years, during which the ultra high frequency region has been most popular, they eventually will have to be dispensed with and replaced by the more modern type of transmitter, such as used on the lower frequency amateur band.

The master-oscillator, power-amplifier (MOPA), is unquestionably the most satisfactory on frequencies as high as 60 megacycles. However, as we approach higher frequencies, the circuits become more unwieldy and very difficult to manage. On the 5-meter (56 to 60 mc.) band, the MOPA should be adopted by every "Ham" who is seriously interested in the betterment of conditions now existing.

In Fig. 5, we have shown the MOPA which uses the type 89 receiving tubes. One is used as an oscillator in the *tritet* circuit with its grid circuit tuned to 10 meters and the plate circuit to 5. This is followed by two 89's employed as screen-grid amplifiers in push-pull. This is very much superior to the previously described circuits inasmuch while the amplifier is being modulated there is no appreciable frequency shift, due to the fact that there is considerable isolation between the actual signal generator and the modulated amplifier. The amplifier being removed by 30 megacycles from the frequency of the oscillator accounts for its excellent stability during modulation. While in the previously explained circuits the oscillator will change frequency as much as 100 kc. during modulation.

In Fig. 6 we have the new 6L6 Beam tube used in the MOPA circuit. This is unquestionably the most superior arrangement up to the time of this writing. Due to the construction of the tube excellent efficiency may be obtained in the 5-meter band even with a single-ended-amplifier. The circuit line-up is essentially the same as the 89 transmitter shown in Fig. 5. The oscillator is tuned to 10 meters and "doubling"

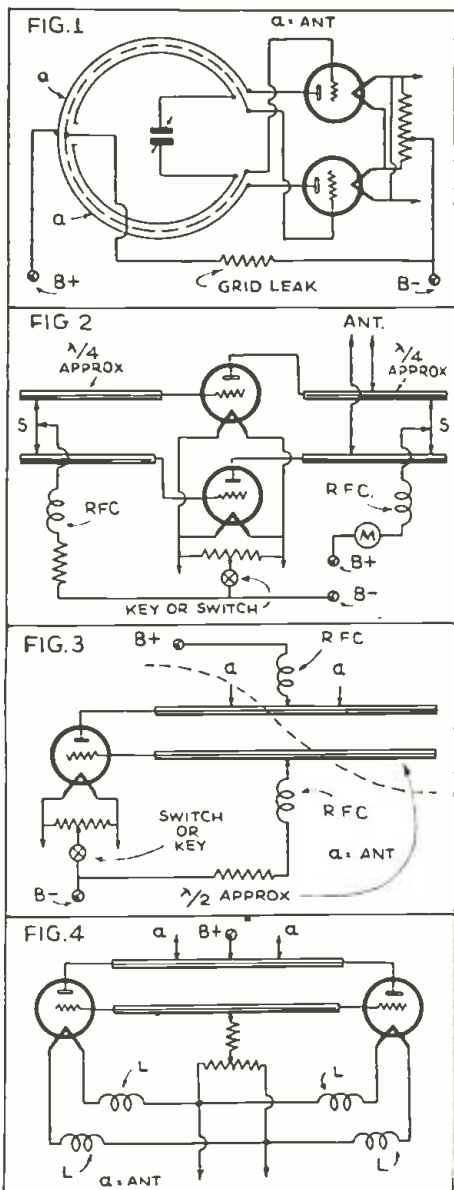

The simplest of all ultra-high frequency transmitters is shown in Fig. 1. Figs. 2, 3, and 4 show "long lines" or linear oscillator.

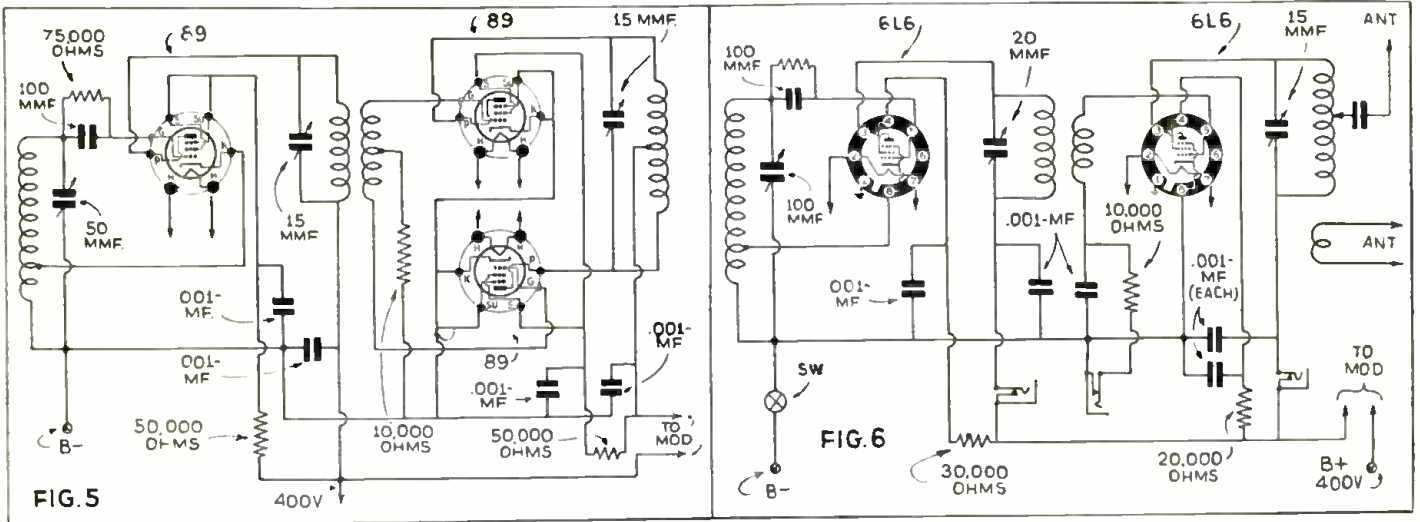

Two very popular 5-meter MOPA's; one uses type 89's, while the other uses type 6L6's.

takes place in the plate circuit, while the second 6L6 operates as a screen-grid amplifier. With 400 volts on the plate, it is possible to obtain 20 watts of R.F. output from the 6L6 amplifier. It may be advisable to include a word of warning at this point that the 6L6's are made in two types; one with a glass envelope and another with a metal envelope. For 5 meters, the metal tube is recommended, inasmuch as a number of extensive tests have proven that it is more stable and far superior in operation, requiring no neutralizing while the excitation voltage is being applied.

No intricate shielding was found necessary with these tubes while the glass tubes required considerable shielding to

All of the popular ultra high frequency transmitters are described in this article. The MOPA's are especially recommended for 5-meter operation.

gether with neutralizing and were no more efficient.

If one is not satisfied with the 20

watts output from the circuit shown in Fig. 6, two 6L6 amplifiers may be added and the diagram is shown in Fig. 7. The amplifier in Fig. 7 added to the two tube transmitter in Fig. 6 will provide some 50 watts output. Here also the metal tubes should be used. For best results with the 6L6, by-passing should be done right at the tube socket! In Fig. 7A we have shown how the metal shell, the cathode, and one side of the heater are all connected right at the socket and grounded to the metal chassis, (a metal chassis is recommended in all (Continued on page 436)

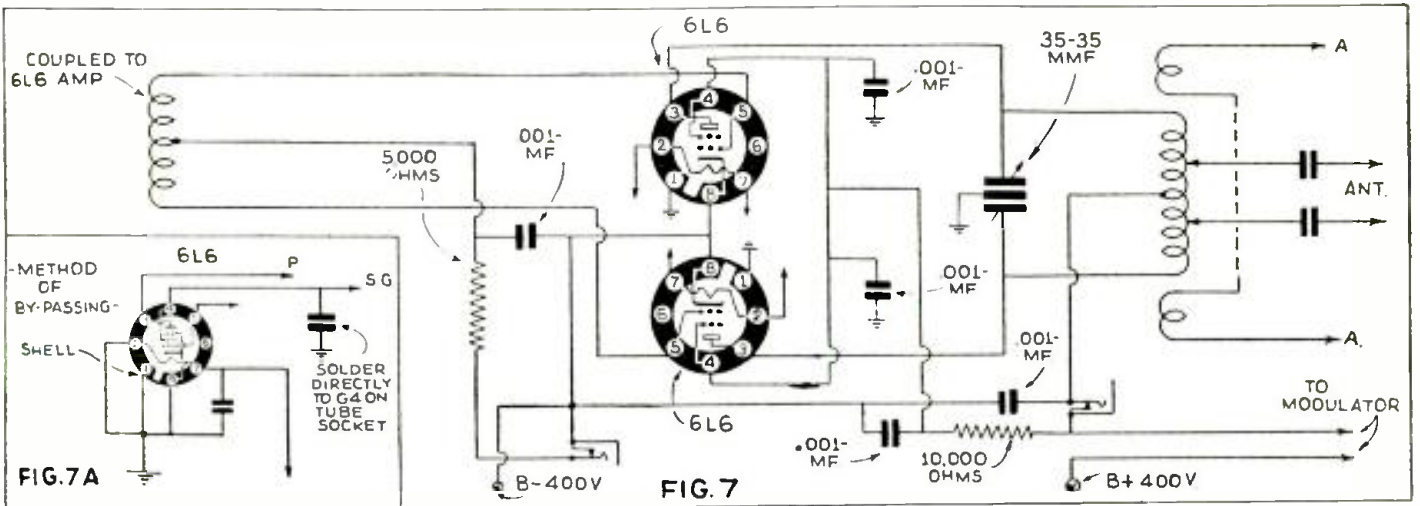

A push-pull amplifier using 6L6's for the 2-tube 6L6 MOPA.

Audio Oscillator and Amplifier

● ONE of the handiest apparatus to have around a radio shack is an extra stage of audio-frequency amplification, one that can be hung on any receiver without the bother of having to tap into the receiver's power-pack. If this audio amplifier can be converted into an audio oscillator without the delay of waiting for a soldering iron to heat up, one indeed has a piece of equipment that has many applications.

The accompanying diagram shows the simple hook-up of such a stage. All one needs to build it is:

- 1 baseboard, 6"x8"
- 1 seven-prong tube socket (small)
- 6 binding posts
- 1 screen-grid clip
- 1 small battery clip
- 1 high-quality audio transformer

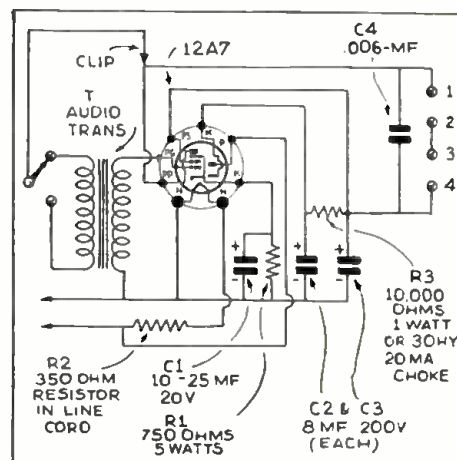

- 1 12A7 vacuum tube.
- 1 10 to 25 mfd., 20 volt electrolytic condenser
- 2 8 mfd., 200 volt electrolytic condensers
- 1 .006 mfd., 200 volt paper or mica condenser

Left—Novel audio oscillator.

- 1 750 ohm, 5 watt resistor
 - 1 350 ohm line cord
 - 1 10,000 ohm, 1 watt resistor (or a 30 henry, 20 m.a. choke)
- The parts are mounted in the conventional layout.

To use as an audio amplifier, dis-

(Continued on page 441)



Joe Miller in his short-wave "Listening Den." In the background the "Short Wave Scout" Trophy. Note the receiver which has borne the hunt of Joe's "world-girdling" ether wave journeys—it's a National SW-58. (List. post in Brooklyn, N.Y.)

LET'S "LISTEN IN"

With

Joe Miller

"King of DX-ers"

ALL
TIMES
E.S.T.

Winner of Thirtieth "Short Wave Scout" Trophy

● WELCOME to our DX page, all of you OMs of the DX fraternity!

In attempting this DX column, we are "breaking the ice" for a feature which, if enough favorable response is received from you DXing OMs, will be continued as a regular monthly DX review.

We'll start with a review of last month's (Aug.) DX. Due to the rather high noise-level prevailing throughout the month, DX was almost always limited to frequencies above 7 megacycles.

China

XOJ, Shanghai, China, 15.80 mc. continues to be one of the steadiest Asiatic phones, being heard in communication with either JVD or JVF at all hours, seemingly, having been logged from as early as 8 p.m., to midnight, at 3:50 a.m. and agn at 6:25 a.m., when a YL at the Mike was heard calling San Francisco, XOJ having a very good R6-7 signal at this time. However, XOJ hasn't a very strong signal in the evenings, so we suggest careful tuning, else you may pass right over them! Check JVD, the usual contact, or JVF,



Mozambique Verifies!!! The most beautiful veri card from the rarest of catches! Coloring all red with black bands next to the call letters.. The DX-er's dream: CR7AA.

and if either is heard, then the chances are that XOJ is on too!

Then there is JIB, in Formosa, or Taiwan, as it is now called, on 28.49 meters. JIB, usually heard around 5 a.m., has been heard as late as 5:45 a.m., transmitting musical programs, with an average R6 signal. JIB can easily be "spotted," as they are just on the HIGH FREQUENCY side of VLK, 10:52 mc., which station is on almost daily between 1-6 a.m. JIB has been verified here on the regular "J" QSL,

received from the "J's" Tokio address, as has JIC.

Sumatra

YBG, Medan, Sumatra, on 10.43 mc. is another "easy" Asiatic DX catch. This DX ace is being heard very often of late, always phoning PLV, 9.415 mc. The regular daily schedule of YBG, in a letter received from the station, is given as from 5:30-6:30 a.m. We will guarantee that if you real DXers will set ur alarms a bit earlier for a week, you'll be the proud owner of logs on both of these FB Asiatics. Always

BANDOENG, June 4th, 1936.

Dear Mr. Miller,

Your report on station P N I 8775 kc/sec. dated September 5th, 1935, checks correctly with the station log.

Thank you.

J. Sanders
J SANDERS
Engineer in-Charge
Java Wireless Stations
Bandung Java

PNI—This rare catch is located at Makassar in Celebes Island, Netherland Indies. Well worth logging!

check YBG by tuning for PLV, and if PLV is heard then that 10.43 mc. sig you're hearing is very likely YBG!

PNI, located at Makassar, Celebes, also in the Dutch East Indies, on 8.775 mc., is another DX ace which may sometimes join up with above stations to make a trio. PNI was heard phoning PLV at 5:45 a.m. just after YBG had dropped out of the trio. PNI is most often heard on Mondays from 4-5 a.m., and puts in a really good signal at this time usually contacting PLV. If you have logged ZBW on 8.75 mc., at Hong Kong, you will know where to look for PNI, just on the HIGH FREQUENCY side of ZBW.

Africa

Algiers, on 8.96 mc., an African and an easy one at that, is heard here dly, in contact with TYA2, Paris, 9.037 mc., between 12:30-1:30 a.m., and also quite

regularly between 4-5:30 p.m. Side band secrecy is used, whereby only one side of the modulated carrier wave is used to transmit the voice. Upon tuning in Algier's carrier, most of

EASAB — This hard-to-get African sends a fine card with printing in light blue. Best heard in U.S.A. in midwinter.

We take pleasure in presenting the first of a brand new series on "DX" hunting by Joseph H. Miller. Mr. Miller is well-known as an accurate "live-wire" short-wave "listener." He won our *Short Wave Scout* silver trophy as announced in the September number. Let us know if you like this new feature—a post-card will do. *But send it!* —Editor.

the time an R9, one should tune to the LOW FREQ side of the carrier, near oscillation, and if traffic is in operation, a voice will be heard, quite distorted, but plain enough to log.

This nice DX catch will usually verify in one month, and all reports should be addressed to: Service Algerien des P.T.T., Direction des Services Techniques Regionaux et Speciaux, 137 Rue de Constantine, Alger, Algeria.

Japan

JVQ, Japan, on 7.47 mc. was heard one morning at 5:50 a.m., with a FB signal, phoning some unknown. Having to "shove off" for work, we were unable to pursue the other side of this distant contact.

EHZ, another "easy" African located at "El Tablero," Tenerife, Canary Islands, on 10.37 mc., is being heard daily between the hours of 5 to 6:30 a.m., phoning EDN, Madrid, on 10.07 mc., though both signals are generally heard "standing by." These stations may be "spotted" by their "bumpy" carriers, and always heard with a good signal here. These are always on together, so if you hear one sig, check it by tuning for the other. Then when one is heard phoning, by quickly tuning to the other you will have logged both, and added a new African phone to your DX record.

Both EHZ and EDN can be verified by sending reports to the following QRA: Companhia Telefonica Nacional de Espana, S.A., Piy Margall 2, Madrid, Spain, and, from present indications, you'd better send ur reports in a

(Continued on page 440)





World S-W Station List

Complete List of Broadcast, and Telephone Stations

All the stations in this list use telephone transmission of some kind. Note: Stations marked with a star ★ are the most active and easily heard stations and transmit at fairly regular times. Please write to us about any new sta-

tions or other important data that you learn through announcements over the air or correspondence with the stations. Stations are classified as follows: C—Commercial phone. B—Broadcast service. X—Experimental transmissions.

Around-the-Clock Listening Guide

It is a good idea to follow a general schedule as far as wavelength in relation to the time of the day is concerned. The observance of these simple rules will save time.

during bright daylight, listen between 13 and 19 meters (21540 to 15800 kc.) To the east of the listener, from about 4 p.m.-5 a.m., the 19-35 meter will be found very productive. To the west of the listener this same

band is generally found best from about 12 m. until 7 a.m. (After dark, results above 35 meters are usually much better than during daylight.) These general rules hold for any location in the Northern Hemisphere.

Short-Wave Broadcasting, Experimental and Commercial Radiophone Stations

NOTE: To convert kc. to megacycles (mc.) shift decimal point 3 places to left: Thus, read 21540 kc. as 21.540 mc.

<p>31600 kc. W2XDU -BX. 9.494 meters ATLANTIC BROADCASTING CO. 485 MADISON AVE., N.Y.C. Relays WABC daily 5-10 p.m., Sat., Sun. 12:30-5, 6-9 p.m.</p> <p>31600 kc. W4XCA -BX. 9.494 meters MEMPHIS, TENN. Relays WMC daily</p> <p>31600 kc. W8XAI -BX. 9.494 meters STROMBERG CARLSON CO. ROCHESTER, N.Y. Relays WHAM daily 7:30 a.m.-12.05 a.m.</p> <p>31600 kc. W8XWJ -BX. 9.494 meters PENOBSCOT TOWER DETROIT, MICH. Daily 6 a.m.-12:30 a.m. Sun. 8 a.m.-12 M.</p> <p>21540 kc. W8XK -B. 13.93 meters WESTINGHOUSE ELECTRIC PITTSBURGH, PA. 7-9 a.m.; relays KDKA</p> <p>21530 kc. GSJ -B. 13.93 meters DAVENTRY B.B.C., BROADCASTING HOUSE, LONDON, ENGLAND</p> <p>21520 kc. W2XE -B. 13.94 meters ATLANTIC BROADCASTING CORP. 485 Madison Ave., N.Y.C. Relays WABC 7:30 a.m.-1 p.m.</p> <p>21470 kc. GSH 13.97 meters DAVENTRY B.B.C., BROADCASTING HOUSE, LONDON, ENGLAND 6-8:45 a.m.</p> <p>21420 kc. WKK -C. 14.01 meters AMER. TEL. & TEL. CO., LAWRENCEVILLE, N. J. Calls S. America 8 a.m.-4 p.m.</p> <p>21080 kc. PSA -C. 14.23 meters RIO DE JANEIRO, BRAZIL Works WKK Daytime</p> <p>21060 kc. WKA -C. 14.25 meters LAWRENCEVILLE, N. J. Calls England noon</p> <p>21020 kc. LSN6 -C. 14.27 meters HURLINGHAM, ARG. Calls N. Y. C. 8 a.m.-5 p.m.</p> <p>20860 kc. EHY-EDM -C. 14.38 meters MADRID, SPAIN Works S. America, mornings.</p> <p>20700 kc. LSY -C. 14.49 meters MONTE GRANDE ARGENTINA Tests irregularly</p> <p>20380 kc. GAA -C. 14.72 meters RUGBY, ENGLAND Calls Argentina, Brazil, mornings</p>	<p>20040 kc. OPL -C. 14.97 meters LEOPOLDVILLE, BELGIAN CONGO Works with ORG in morning</p> <p>20020 kc. DHO -C. 14.99 meters NAUEN, GERMANY Works S. America, mornings</p> <p>19900 kc. LSG -C. 15.08 meters MONTE GRANDE, ARGENTINA Tests irregularly, daytime</p> <p>19820 kc. WKN -C. 15.14 meters LAWRENCEVILLE, N. J. Calls England, daytime</p> <p>19680 kc. CEC -C. 15.24 meters SANTIAGO, CHILE Works Buenos Aires and Colombia daytime</p> <p>19650 kc. LSN5 -C. 15.27 meters HURLINGHAM, ARGENTINA Calls Europe, daytime</p> <p>19600 kc. LSF -C. 15.31 meters MONTE GRANDE, ARGENTINA Tests irregularly, daytime</p> <p>19480 kc. GAD -C. 15.4 meters RUGBY, ENGLAND Works with Kenya, Africa, early morning</p> <p>19355 kc. FTM -C. 15.50 meters ST. ABBISE, FRANCE Calls Argentine, mornings</p> <p>19345 kc. PMA -B-C. 15.51 meters BANDONG, JAVA Calls Holland, early a.m. Broadcasts Tues., Thur., Sat., 10:00-10:30 a.m. Irregular</p> <p>19260 kc. PPU -C. 15.58 meters RIO DE JANEIRO, BRAZIL Works with France mornings</p> <p>19220 kc. WKF -C. 15.60 meters LAWRENCEVILLE, N. J. Calls England, daytime</p> <p>19200 kc. ORG -C. 15.62 meters RUYSELEDE, BELGIUM Works with OPL mornings</p> <p>19160 kc. GAP -C. 15.66 meters RUGBY, ENGLAND Calls Australia, early a.m.</p> <p>18970 kc. GAQ -C. 15.81 meters RUGBY, ENGLAND Calls S. Africa, mornings</p> <p>18890 kc. ZSS -C. 15.88 meters KLIPHEUVEL, S. AFRICA Works Rugby 6:30 a.m.-12 n</p> <p>18830 kc. PLE -C. 15.93 meters BANDONG, JAVA Calls Holland, early a. m.</p>	<p>18680 kc. OCI -C. 16.06 meters LIMA, PERU Works various S.A. stations daytime</p> <p>18620 kc. GAU -C. 16.11 meters RUGBY, ENGLAND Calls N. Y., daytime</p> <p>18345 kc. FZS -C. 16.35 meters SAIGON, INDO-CHINA Phones Paris, early morning</p> <p>18340 kc. WLA -C. 16.38 meters LAWRENCEVILLE, N. J. Calls England, daytime</p> <p>18310 kc. GAS -C. 16.38 meters RUGBY, ENGLAND Calls N. Y., daytime</p> <p>18299 kc. YVR -C. 16.39 meters MARACAY, VENEZUELA Works Germany, mornings</p> <p>18250 kc. FTO -C. 16.43 meters ST. ABBISE, FRANCE Calls S. America, daytime</p> <p>18200 kc. GAW -C. 16.48 meters RUGBY, ENGLAND Calls N. Y., daytime</p> <p>18135 kc. PMC -C. 16.54 meters BANDONG, JAVA Phones Holland, early a. m.</p> <p>18115 kc. LSY3 -C. 16.56 meters MONTE GRANDE, ARGENTINA Tests irregularly</p> <p>18040 kc. GAB -C. 16.63 meters RUGBY, ENGLAND Calls Canada morn. and early aftn.</p> <p>17810 kc. PCV -C. 16.84 meters KOOTWIJK, HOLLAND Calls Java, 6-9 a. m.</p> <p>17790 kc. GSG -B. 16.86 meters DAVENTRY B.B.C., BROADCASTING HOUSE, LONDON, ENGLAND 6-8:45 a.m., 9-10:30 a.m.</p> <p>17780 kc. W3XAL -B. 16.87 meters NATIONAL BROAD. CO. BOUND BROOK, N. J. Relays WJZ, Daily exc. Sun. 8 a.m.-4 p.m.</p> <p>17775 kc. PHI -B. 16.88 meters HUIZEN, HOLLAND 8-10 a.m. daily except Tue. and Wed.</p> <p>17760 kc. W2XE -B. 16.89 meters ATLANTIC BROADCASTING CORP. 485 Madison Ave., N.Y.C.</p>	<p>17760 kc. DJE -B. 16.89 meters BROADCASTING HOUSE BERLIN, GERMANY 12:05-5:15; 5:55-11 a.m.</p> <p>17760 kc. IAC -C. 16.89 meters PISA, ITALY Calls ships, 6:30-7:30 a. m.</p> <p>17741 kc. HSP -C. 16.91 meters BANGKOK, SIAM Works Germany 4-7 a.m.</p> <p>17650 kc. XGM -C. 17 meters SHANGHAI, CHINA Works London 7-9 a.m.</p> <p>17520 kc. DFB -C. 17.12 meters NAUEN, GERMANY Works S. America near 9:15 a.m.</p> <p>17510 kc. VWY2 -C. 17.13 meters KIRKEE, INDIA Works Rugby 2-7 a.m.</p> <p>17310 kc. W3XL -X. 17.33 meters NATIONAL BROAD. CO. BOUND BROOK, N. J. Tests irregularly</p> <p>17120 kc. WOO -C. 17.52 meters A. T. & T. CO., OCEAN GATE, N. J. Calls ships</p> <p>17080 kc. GBC -C. 17.58 meters RUGBY, ENGLAND Calls Ships</p> <p>16270 kc. WLK -C. 18.44 meters LAWRENCEVILLE, N. J. Phones Arg., Braz., Peru, daytime</p> <p>16270 kc. WOG -C. 18.44 meters OCEAN GATE, N. J. Calls England, morning and early afternoon</p> <p>16240 kc. KTO -C. 18.47 meters MANILA, P. I. Calls Cal., Tokio and ships 8-11:30 a.m.</p> <p>16233 kc. FZR3 -C. 18.48 meters SAIGON, INDO-CHINA Calls Paris and Pacific Isles</p> <p>15880 kc. FTK -C. 18.90 meters ST. ABBISE, FRANCE Phones Saigon, morning</p> <p>15865 kc. CEC -C. 18.91 meters SANTIAGO, CHILE Works other S.A. stations afternoons</p> <p>15810 kc. LSL -C. 18.98 meters HURLINGHAM, ARGENTINA Calls Brazil and Europe, daytime</p> <p>15760 kc. JYT -X. 19.04 meters KEMIKWA-CHO, CHIBA-KEN, JAPAN Irregular in late afternoon and early morning</p>	<p>15660 kc. JVE -C. 19.16 meters NAZAKI, JAPAN Phones Java 3-5 a.m.</p> <p>15620 kc. JVF -C. 19.2 meters NAZAKI, JAPAN Phones U.S., 5 a.m. & 4 p.m.</p> <p>15460 kc. KKR -C. 19.4 meters RCA COMMUNICATIONS, BOLINAS, CAL. Tests irregularly</p> <p>15415 kc. KWO -C. 19.48 meters DIXON, CAL. Phones Hawaii 2-7 p.m.</p> <p>15370 kc. HAS3 -B. 19.52 meters BUDAPEST, HUNGARY Broadcasts Sundays, 9-10 a.m.</p> <p>15360 kc. DZG -X.C. 19.53 meters REICHSPOTZENSTRALAMT, ZEESEN, GERMANY Tests irregularly</p> <p>15355 kc. KWU -C. 19.53 meters DIXON, CAL. Phones Pacific Isles and Japan</p> <p>15340 kc. DJR -B. 19.56 meters BROADCASTING HOUSE, BERLIN, GERMANY 8-10 a.m.</p> <p>15330kc. W2XAD -B. 19.56 meters GENERAL ELECTRIC CO. SCHENECTADY, N. Y. Relays WGY 10 a.m.-4:30 p.m.</p> <p>15310 kc. GSP -B. 19.6 meters DAVENTRY B.B.C., BROADCASTING HOUSE, LONDON, ENGLAND 6-8 p.m.</p> <p>15290 kc. LRU -B. 19.62 meters "EL MUNDO" BUENOS AIRES, ARGENTINA, S. A. Daily 7 a.m.-3:45 p.m.</p> <p>15280 kc. DJQ -B. 19.63 meters BROADCASTING HOUSE BERLIN, GERMANY 5-7:15-11 a.m., 4:50-10:45 p.m.</p> <p>15270 kc. W2XE -B. 19.65 meters ATLANTIC BROADCASTING CORP., 485 Madison Ave., N.Y.C. WABC daily, 1-5 p.m.</p> <p>15260 kc. GSI -B. 19.65 meters DAVENTRY B.B.C., BROADCASTING HOUSE, LONDON, ENGLAND 12:15-3:30 p.m.</p> <p>15252 kc. RIM -C. 19.67 meters TACHKENT, U.S.S.R. Phones RK1 near 7 a.m.</p> <p>15250 kc. W1XAL -B. 19.67 meters BOSTON, MASS. Irregular, in morning</p>
--	---	---	--	--

(All Schedules Eastern Standard Time)

15245 kc. TPA2

-B- 18.88 meters "RADIO COLONIAL" PARIS, FRANCE Service de la Radiodiffusion 98, bis, Blvd. Haussmann 2-3, 5:55-11 a.m.

15230 kc.

-B- 19.70 meters "RADIO PODEBRADY," CZECHOSLOVAKIA Testing at 4 a.m., 10 a.m., and 2 p.m.

15220 kc. PCJ

-B- 19.71 meters N.V. PHILIPS RADIO EINDHOVEN, HOLLAND Tues. 4:30-6 a.m. Wed. 8-11 a.m. Sun. 6-7 a.m.

15210 kc. W8XK

-B- 19.72 meters WESTINGHOUSE ELECTRIC & MFG. CO. PITTSBURGH, PA. 9 a.m.-7 p.m. Relays KDKA

15200 kc. DJB

-B- 19.74 meters BROADCASTING HOUSE BERLIN, GERMANY 12:05-5:15, 5:55-11 a.m., 4:50-10:55 p.m. Sun. also 11:10 a.m.-12:20 p.m.

15180 kc. GSO

-B- 19.76 meters B.B.C. BROADCASTING HOUSE, LONDON, ENGLAND 12:15-3:40 p.m.

15180 kc. RAN

-B- 19.76 meters MOSCOW, U.S.S.R. Sun. 1-2 p.m.

15140 kc. GSF

-B- 19.82 meters DAVENTRY, B.B.C. BROADCASTING HOUSE, LONDON, ENGLAND 9 a.m.-12 n., 3:40-5:45 p.m.

15130 kc.

-B- 19.82 meters NIROM BANDONG, JAVA 3:30-11 a.m.

15120 kc. HVJ

-B- 19.83 meters VATICAN CITY 10:30 to 10:45 a.m., except Sunday Sat. 10-10:45 a.m.

15110 kc. DJL

-B- 19.85 meters BROADCASTING HOUSE, BERLIN, GERMANY 12-2, 8-10 a.m., 11:35 a.m.-4:30 p.m. Irregular 4:50-10:45 p.m. Also 6-8 a.m. Sun.

15090 kc. RKI

-B-C- 19.88 meters MOSCOW, U.S.S.R. Phones Tashkent near 7 a.m. and relays RNE on Sundays 10-11 a.m.

15070 kc. PSD

-C- 19.91 meters RIO DE JANEIRO, BRAZIL Calls N.Y. Buenos Aires and Europe, daytime

15055 kc. WNC

-C- 19.92 meters HIALEAH, FLORIDA Calls Central America, daytime

14980 kc. KAY

-C- 20.03 meters MANILA, P. I. Phones Pacific Isles

14970 kc. LZA

-B-C- 20.04 meters RADIO GARATA, SOFIA, BULGARIA Broadcasts Sun. 12:30-8 a.m., 10 a.m.-4:30 p.m., Daily 5-7 a.m., Tues. and Thurs., 1-3 p.m.

14960 kc. PSF

-C- 20.43 meters RIO DE JANEIRO, BRAZIL Works with Buenos Aires daytime

14950 kc. HJB

-C- 20.07 meters BOGOTA, COL. Calls WNC, daytime

14940 kc. HII

-C- 20.08 meters CIUDAD TRUJILLO, D.R. Phones WNC daytime

14940 kc. HJA3

-C- 20.08 meters BARRANQUILLA, COL. Works WNC daytime

14845 kc. OCJ2

-C- 20.21 meters LIMA, PERU Works other S.A. stations daytime

14653 kc. GBL

-C- 20.47 meters RUGBY, ENGLAND Works JWH 1-7 a.m.

14640 kc. TYF

-C- 20.49 meters PARIS, FRANCE Works Saigon and Cairo 3-7 a.m., 12 n.-2:30 p.m.

14600 kc. JVH

-B-C- 20.55 meters. NAZAKI, JAPAN Phones Hiroo 4-8 a.m. Broadcasts 12 m-l a.m. Tues. and Fri. 2-3 p.m. Mon. and Thurs. 4-5 p.m.

14590 kc. WMN

-C- 20.56 meters LAWRENCEVILLE, N. J. Phones England morning and afternoon

14535 kc. HBJ

-B- 20.64 meters RADIO NATIONS, GENEVA, SWITZERLAND Broadcasts irregularly

14530 kc. LSN

-C- 20.65 meters HURLINGHAM, ARGENTINA Calls N.Y.C. afternoons

14500 kc. LSM2

-C- 20.69 meters HURLINGHAM, ARGENTINA Calls Rio and Europe daytime

14485 kc. TIR

-C- 20.71 meters CARTAGO, COSTA RICA Phones Cen. Amer. & U.S.A. Daytime

14485 kc. HPF

-C- 20.71 meters PANAMA CITY, PAN. Phones WNC daytime

14485 kc. TGF

-C- 20.71 meters GUATEMALA CITY, GUAT. Phones WNC daytime

14485 kc. YNA

-C- 20.71 meters MANAGUA, NICARAGUA Phones WNC daytime

14485 kc. HRL5

-C- 20.71 meters NACAOME, HONDURAS Works WNC daytime

14485 kc. HRF

-C- 20.71 meters TEGUCIGALPA, HONDURAS Works WNC daytime

14470 kc. WMF

-C- 20.73 meters LAWRENCEVILLE, N. J. Phones England morning and afternoon

14460 kc. DZH

-C-X- 20.75 meters REICHSPOSTZENSTRALMT. ZEESEN, GERMANY Irregular

14440 kc. GBW

-C- 20.78 meters RUGBY, ENGLAND Calls U.S.A., afternoon

13990 kc. GBA

-C- 21.44 meters RUGBY, ENGLAND Calls Buenos Aires, late afternoon

13820 kc. SUZ

-C- 21.71 meters ABDO ZABAL, EGYPT Works with Europe 11 a.m.-2 p.m.

13690 kc. KKZ

-C- 21.91 meters RCA COMMUNICATIONS, BOLINAS, CAL. Tests irregularly

13635 kc. SPW

-B- 22 meters WARSAW, POLAND Mon., Wed., Fri. 11:30 a.m.-12:30 p.m. Irregular at other times

13610 kc. JYK

-C- 22.04 meters KEMIKAWA-CHO, CHIBA-KEN, JAPAN Phone California till 11 p. m.

13585 kc. GBB

-C- 22.08 meters RUGBY, ENGLAND Calls Egypt & Canada, afternoons

13415 kc. GCJ

-C- 22.36 meters RUGBY, ENGLAND Calls Japan & China early morning

13390 kc. WMA

-C- 22.40 meters LAWRENCEVILLE, N. J. Phones England morning and afternoon

13380 kc. IDU

-C- 22.42 meters ASMARA, ERITREA, AFRICA Works with Rome daytime

13345 kc. YVQ

-C- 22.46 meters MARACAY, VENEZUELA Calls Hialeah daytime

13285 kc. CGA3

-C- 22.58 meters DRUMMONDVILLE, QUE., CAN. Works London and Ships afternoons

13075 kc. VPD

-X- 22.84 meters SUVA, FIJI ISLANDS Daily exc. Sun. 12:30-1:30 a.m.

12840 kc. WOO

-C- 23.36 meters OCEAN GATE, N. J. Calls ships

12825 k. CNR

-B-C- 23.39 meters DIRECTOR GENERAL Telegraph and Telephone Stations, Rabat, Morocco Broadcasts, Sunday, 7:30-9 a. m.

12800 kc. IAC

-C- 23.45 meters PISA, ITALY Calls Italian ships, mornings

12780 kc. GBC

-C- 23.47 meters RUGBY, ENGLAND Calls ships

12396 kc. CT1GO

-B- 24.2 meters PAREDE, PORTUGAL Sun. 10-11:30 a.m., Tues., Thur., Fri. 1:00-2:15 p.m.

12325 kc. DAF

-C- 24.34 meters NORDDEICH, GERMANY Works German ships daytime

12290 kc. GBU

-C- 24.41 meters RUGBY, ENGLAND Calls N.Y.C., afternoon

12250 kc. TYB

-C- 24.49 meters PARIS, FRANCE Irregular

12235 kc. TFI

-B-C- 24.52 meters REYKJAVIK, ICELAND Phones England mornings, Broadcasts Sun. 1:40-2:30 p.m.

12215 kc. TYA

-C- 24.56 meters PARIS, FRANCE Works French Ships in morning and afternoon

12150 kc. GBS

-C- 24.69 meters RUGBY, ENGLAND Calls N.Y.C., afternoon

12130 kc. DZE

-C- 24.73 meters REICHSPOSTZENSTRALMT. ZEESEN, GERMANY Tests irregularly

12060 kc. PDV

-C- 24.88 meters KOOTWIJK, HOLLAND Tests irregularly

12000 kc. RNE

-B- 25 meters MOSCOW, U. S. S. R. Sun. 6-9, 10-11 a.m., 12:30-6 p.m. Wed. 6-7 a.m. Daily 12:30-6 p.m.

11991 kc. FZS2

-C- 25.02 meters SAIGON, INDO-CHINA Phones Paris, morning

11950 kc. KKQ

-X- 25.10 meters BOLINAS, CALIF. Tests, irregularly, evenings

11940 kc. FTA

-C- 25.13 meters STE. ASSISE, FRANCE Phones CNR morning, Hurlingham, Arac., nights

11880 kc. TPA3

-B- 25.23 meters "RADIO COLONIAL" PARIS, FRANCE 2-5 a.m., 12:15-6 p.m.

11870 kc. W8XK

-B- 25.26 meters WESTINGHOUSE ELECTRIC & MFG. CO. PITTSBURGH, PA. 5-10:30 p.m. Fri. till 12 m Relays KDKA

11860 kc. YDB

-B- 25.29 meters N.I.R.O.M., SOERABAJA, JAVA Sat. 7:30 p.m.-2 a.m. (Sun.) Daily 10:30 p.m.-2 a.m.

11860 kc. GSE

-B- 25.29 meters DAVENTRY, B.B.C. BROADCASTING HOUSE, LONDON, ENGLAND

11855 kc. DJP

-B-X- 25.31 meters BROADCASTING HOUSE, BERLIN, GERMANY Irregular

11830 kc. W9XAA

-B- 25.36 meters CHICAGO FEDERATION OF LABOR LABOR CHICAGO, ILL. Relays WCFL 6:30 a.m.-4 p.m., 9 p.m.-12 m.

11830 kc. W2XE

-B- 25.36 meters ATLANTIC BROADCASTING CORP. 485 MADISON AVE., N. Y. C. Relays WABC 5-11 p.m.

11820 kc. GSN

-B- 25.38 meters DAVENTRY, B.B.C. BROADCASTING HOUSE, LONDON, ENGLAND 2:15-4:15 a.m., Irregular

11810 kc. HJ4ABA

-B- 25.4 meters P. O. BOX 50, MEDELLIN, COLOMBIA 11:30 a.m.-1 p.m., 6:30-10:30 p.m.

11810 kc. 2RO

-B- 25.4 meters E.I.A.R. Via Montello 5 ROME, ITALY Daily 6:43-10:30, 11:30 a.m.-5:30 p.m., 6-6:20 p.m.; Sun. 6:43-9, 11:30 a.m.-5:30 p.m. Also Mon., Wed., Fri., 6:20-7:30 p.m.

11795 kc. DJO

-B-X- 25.43 meters BROADCASTING HOUSE, BERLIN, GERMANY Irregular

11790 kc. W1XAL

-B- 25.45 meters BOSTON, MASS. Daily 5:15-6:15 p.m. Sun. 5-7 p.m.

11770 kc. DJD

-B- 25.49 meters BROADCASTING HOUSE, BERLIN, GERMANY 11:35 a.m.-4:30 p.m.; 4:50-10:55 p.m.

11760 kc.

-B- 25.51 meters "RADIO PODEBRADY" CZECHOSLOVAKIA Testing at 4 a.m., 10 a.m., 2 p.m. Broadcasts 9-11 p.m. Mon. and Thur.

11750 kc. GSD

-B- 25.53 meters DAVENTRY, B.B.C. BROADCASTING HOUSE, LONDON, ENGLAND 12:15-5:45 p.m., 6-8, 9-11 p.m., 2:15-4:15 a.m.

11730 kc. PHI

-B- 25.57 meters HUIZEN, HOLLAND Irregular

11720 kc. CJRX

-B- 25.6 meters WINNIPEG, CANADA Daily, 8 p. m.-12 m.

11715 kc. TPA4

-B- 25.61 meters "RADIO COLONIAL" PARIS, FRANCE 6:15-10:15 p.m. 10:45 p.m.-1 a.m.

11680 kc. KIO

-X- 25.68 meters KAHUKU, HAWAII Tests in the evening

11595 kc. VRR4

-C- 25.87 meters STONY HILL, JAMAICA, B.W.I. Works WNC daytime.

11560 kc. VIZ3

-X- 25.95 meters AMALGAMATED WIRELESS OF AUSTRALASIA FISKVILLE, AUSTRALIA Calls Canada evening and early a.m.

11500 kc. PMR

-B-C- 26.09 meters BANDOENG, JAVA Broadcasts Daily exc. Sat. 5:30-10:30 or 11 a.m., 6-7:30 p.m. 10:30 p.m.-2 a.m., Sat. 5:30-11:30 a.m., 7:30 p.m.-2 a.m. (Sun.)

11413 kc. CJA4

-C- 26.28 meters DRUMMONDVILLE, QUE., CAN. Tests with Australia irregularly in evening

11200 kc. XBJQ

-X- 26.79 meters BOX 2825, MEXICO CITY, MEX. Irregular

11050 kc. ZLT4

-C- 27.15 meters WELLINGTON, N. ZEALAND Phones Australia and England early a.m.

10970 kc. OCI

-C- 27.35 meters LIMA, PERU Works with Bogota, Col., evenings

10955 kc. HS8PJ

-B-X- 27.38 meters BANGKOK, SIAM Broadcasts 8-10 a.m. Mondays

10840 kc. KWW

-C- 27.68 meters DIXON, CAL. Works with Hawaii evenings.

10770 kc. GBP

-C- 27.85 meters RUGBY, ENGLAND Calls Sydney, Austral. early a. m.

10740 kc. JVM

-B-C- 27.93 meters NAZAKI, JAPAN Broadcasts Tues. and Fri. 2-3 p.m., Phones U.S. 2-7 a.m.

10675 kc. WNB

-C- 28.1 meters LAWRENCEVILLE, N. J. Calls Bermuda, daytime

10670 kc. CEC

-C- 28.12 meters SANTIAGO, CHILE Broadcasts Thurs. Sun. 8:30-9 p.m., Daily 7-7:15 p.m.

10660 kc. JVN

-B-C- 28.14 meters NAZAKI, JAPAN Phones Europe 3-8 a.m. Broadcasts daily 12 m-l a.m., 2-8 a.m. Mon. and Thurs. 4-5 p.m.

10550 kc. WOK

-C- 28.44 meters LAWRENCEVILLE, N. J. Phones Arge., Braz., Peru, nights

10520 kc. VLK

-C- 28.51 meters SYDNEY, AUSTRALIA Calls Rugby, early a.m.

10430 kc. YBG

-C- 28.76 meters MEDAN, SUMATRA 5:30-6:30 a. m., 7:30-8:30 p. m.

10420 kc. XGW

-C- 28.79 meters SHANGHAI, CHINA Calls Manila and England, 6-9 a. m. and California late evening

10410 kc. PDK

-C- 28.80 meters KOOTWIJK, HOLLAND Calls Java 7:30-9:40 a. m.

10410 kc. KES

-X- 28.80 meters BOLINAS, CALIF. Tests evenings

10350 kc. LSX

-C- 28.98 meters MONTE GRANDE, ARGENTINA Tests irregularly 8 p.m.-12 mid-night.

10330 kc. ORK

-B-C- 29.04 meters RUYSSSELEDE, BELGIUM Broadcasts 1:30-3 p.m.

<p>10300 kc. LSL2 -C- 29.13 meters HURLINGHAM, ARGENTINA Calls Europe, evenings</p> <p>10290 kc. DZC -X- 29.16 meters REICHSPOSTZENSTRA- LAMPT, ZEESEN, GERMANY Broadcasts irregularly</p> <p>10260 kc. PMN -B-C- 29.74 meters BANDOENG, JAVA Calls Australia 5 a.m. Broadcasts Daily exc. Sat. 6-7:30 p.m., 10:30 p.m.-2 a.m., 5:30- 10:30 or 11 a.m., Sat. 5:30-11:30 a.m., 7:30 p.m.-2 a.m. (Sun.)</p> <p>10250 kc. LSK3 -C- 29.27 meters HURLINGHAM, ARGENTINA Calls Europe and U. S., after- noon and evening</p> <p>10220 kc. PSH -C- 29.35 meters RIO DE JANEIRO, BRAZIL</p> <p>10170 kc. RIO -C- 29.5 meters BAKOU, U.S.S.R. Works with Moscow 10 p.m.-5 a.m.</p> <p>10169 kc. HSJ -CX- 29.5 meters BANGKOK, SIAM Tests 9-10 a.m. Mon., Wed., Thur.</p> <p>10140 kc. OPM -C- 29.55 meters LEOPOLDVILLE, BELGIAN CONGO Phones around 3 a.m. and 1- 4 p.m.</p> <p>10080 kc. RIR -C- 29.76 meters TIFLIS, U.S.S.R. Works with Moscow early morning.</p> <p>10070 kc. EDM-EHY -C- 29.79 meters MADRID, SPAIN Works with S. America evenings</p> <p>10055 kc. ZFB -C- 29.84 meters HAMILTON, BERMUDA Phones N. Y. C. daytime</p> <p>10055 kc. SUV -C- 29.84 meters ABOU ZABAL, EGYPT Works with Europe 1-6 p.m.</p> <p>10042 kc. DZB -X- 29.87 meters ZEESEN, GERMANY Works with Central America and tests 7-9 p.m.</p> <p>9990 kc. KAZ -C- 30.03 meters MANILLA, P.I. Works with Java, Cal. and ships early morning</p> <p>9950 kc. GCU -C- 30.15 meters RUGBY, ENGLAND Calls N.Y.C. evening</p> <p>9930 kc. HKB -C- 30.21 meters BOGOTA, COL. Phones Rio de Janeiro evenings</p> <p>9890 kc. LSN -C- 30.33 meters HURLINGHAM, ARGENTINA Calls New York, evenings</p> <p>9870 kc. WON -C- 30.4 meters LAWRENCEVILLE, N. J. Phones England, evening</p> <p>9860 kc. EAQ -B- 30.43 meters P. O. Box 951 MADRID, SPAIN Daily 5:15-9:30 p.m.; Saturday also 12 n.-2 p.m.</p> <p>9840 kc. JYS -X- 30.49 meters KEMIKAWA-CHO, CHIBA- KEN, JAPAN Irregular, 11:30 p.m.-3 a.m.</p> <p>9840 kc. TI4NRH -B- 30.5 meters AMANDO CEPEDAS MARIN, APARTADO 40, HEREDIA, COSTA RICA Daily 8:30-10, 11:30 p.m.-12 m.</p> <p>9830 kc. COCQ -B- 30.55 meters HAVANA, CUBA Evenings</p>	<p>9800 kc. LSI -C- 30.61 meters MONTE GRANDE, ARGENTINA Tests irregularly</p> <p>9790 kc. GCW -C- 30.64 meters RUGBY, ENGLAND Calls N.Y.C., evening</p> <p>9760 kc. VLJ-VLZ2 -C- 30.74 meters AMALGAMATED WIRELESS OF AUSTRALIA SYDNEY, AUSTRALIA Phones Java and N. Zealand early a.m.</p> <p>9750 kc. WOF -C- 30.77 meters LAWRENCEVILLE, N. J. Phones England, evening</p> <p>9710 kc. GCA -C- 30.89 meters RUGBY, ENGLAND Calls Arg. & Brazil, evenings</p> <p>9675 kc. DZA -C- 31.01 meters ZEESEN, GERMANY Works with Africa and broad- casts 5-7 p.m.</p> <p>9650 kc. YDB -B- 31.09 meters N.I.R.O.M., SOERABAJA, JAVA Daily exc. Sat. 6-7:30 p.m., 5:30- 10:30 or 11 a.m., Sat. 5:30-11:30 a.m.</p> <p>9650 kc. CT1AA -B- 31.09 meters "RADIO COLONIAL" LISBON, PORTUGAL Tues., Thurs., Sat. 3-6 p.m.</p> <p>9650 kc. DGU -C- 31.09 meters NAUEN, GERMANY Works with Egypt in afternoon</p> <p>9645 kc. YNLF -B- 31.1 meters MANAGUA, NICARAGUA 8-9 a.m., 12:30-2:30, 6:30- 10 p.m.</p> <p>9640 kc. LRX -B- 31.12 meters "EL MUNDO" BUENOS AIRES, ARGENTINA 5-9 p.m.</p> <p>9635 kc. 2BRO -B- 31.13 meters E.I.A.R., ROME, ITALY Tues., Thurs., Sat. 6:30-8 p.m.</p> <p>9615 kc. HJ1ABP -B- 31.2 meters P.O. BOX 37, CARTAGENA, COL. 11 a.m.-1 p.m., 5-11 p.m., Sun. 10 a.m.-1 p.m., 3-6 p.m.</p> <p>9605 kc. HP5J -B- 31.24 meters APARTADO 867, PANAMA CITY, PANAMA 11:45 a.m.-1 p.m., 7:30-10 p.m.</p> <p>9600 kc. RAN -B- 31.25 meters MOSCOW, U.S.S.R. Daily 7-7:30 p.m., Sun., Wed. and Fri. 6-8 p.m.</p> <p>9600 kc. CB960 -B- 31.25 meters SANTIAGO CHILE 9:30 p.m. on</p> <p>9595 kc. HBL -B- 31.27 meters LEAGUE OF NATIONS GENEVA, SWITZERLAND Saturdays, 5:30-8:15 p. m. Mon. at 1:45 a.m.</p> <p>9595 kc. HH3W -B- 31.27 meters P.O. BOX A117, PORT-AU-PRINCE, HAITI 1-2, 7-8:30 p.m.</p> <p>9590 kc. PCJ -B- 31.28 meters N. V. PHILIPS RADIO EINDHOVEN, HOLLAND Sun. 2-3, 7-8 p.m. Tues. 1:30-3 p.m. Wed. 7-10 p.m.</p> <p>9590 kc. VK2ME -B- 31.28 meters AMALGAMATED WIRELESS, LTD., 47 YORK ST. SYDNEY, AUSTRALIA Sun. 12:30-2:30 a.m., 4:30-8:30 a.m., 9:30-11:30 a.m.</p> <p>9590 kc. W3XAU -B- 31.28 meters PHILADELPHIA, PA. Relays WCAU Daily 12n-8 p.m.</p>	<p>9585 kc. CQN -B- 31.30 meters MACAO, PORTUGUESE CHINA Mon. and Fri. 7-8:30 a.m.</p> <p>9580 kc. GSC -B- 31.32 meters DAVENTRY, B.B.C., BROADCASTING HOUSE, LONDON, ENGLAND 6-8, 9-11 p.m.</p> <p>9580 kc. VK3LR -B- 31.32 meters Research Section, Postmaster Gen'l's. Dept., 61 Little Collins St., MELBOURNE, AUSTRALIA 3:15-7:30 a.m., except Sun. also Fr. 10 p.m.-2 a.m.</p> <p>9570 kc. W1XK -B- 31.35 meters WESTINGHOUSE ELECTRIC & MFG. CO., SPRINGFIELD, MASS. Relays WBZ, 7 a.m.-1 a.m. Sun. 8 a.m.-1 a.m.</p> <p>9565 kc. VUB -B- 31.36 meters BOMBAY, INDIA 11 a.m.-12:30 p.m., Wed., Thurs., Sat.</p> <p>9560 kc. DJA -B- 31.38 meters BROADCASTING HOUSE, BERLIN 12:05-5:15 a.m., 4:50-10:45 p.m.</p> <p>9555 kc. HJ1ABB -B- 31.38 meters BARRANQUILLA, COL., S.A. P. O. BOX 715 11:30 a.m.-1 p.m., 4:30-10 p.m.</p> <p>9550 kc. HJ1ABE -B- 31.41 meters P.O. BOX 31, CARTAGENA, COLOMBIA Daily 7:30-9 p.m., Mon. also 10 p.m.-12 p.m.</p> <p>9540 kc. DJN -B- 31.42 meters BROADCASTING HOUSE BERLIN, GERMANY 12:05-5:15 a.m., 4:50-10:45 p.m.</p> <p>9530 kc. W2XAF -B- 31.48 meters GENERAL ELECTRIC CO., SCHENECTADY, N. Y. Relays WGY 4 p.m.-12 p.m.</p> <p>9525 kc. LKJ1 -B- 31.49 meters JELOY, NORWAY 5-8 a.m., 11 a.m.-6 p.m.</p> <p>9510 kc. VK3ME -B- 31.55 meters AMALGAMATED WIRELESS, LTD., 167 Queen St., MELBOURNE, AUSTRALIA Daily exc. Sun. 4-7 a.m.</p> <p>9510 kc. GSB -B- 31.55 meters DAVENTRY, B.B.C., BROADCASTING HOUSE, LONDON, ENGLAND 2:15-4:15 a.m., 12:15-5:45 p.m.</p> <p>9500 kc. HJU -B- 31.58 meters NATIONAL RAILWAYS BUENAVENTURA, COLOM- BIA Mon., Wed., Fri. 8-11 p.m.</p> <p>9500 kc. PRF5 -B- 31.58 meters RIO DE JANEIRO, BRAZIL Irregularly 4:45-5:45 p.m.</p> <p>9450 kc. TGW -B- 31.75 meters MINISTRE DE FOMENTO GUATEMALA CITY, GUATEMALA Daily 11 a.m.-1 p.m., 7-8, 9-11 p.m., Sat. 9 p.m.-5 a.m. (Sun.)</p> <p>9428 kc. COCH -B- 31.8 meters 2 B ST., VEDADO, HAVANA, CUBA Daily 8 a.m.-7 p.m., Sun. 11 a.m.-12 n., 8:30-9:30 p.m.</p> <p>9415 kc. PLV -C- 31.87 meters BANDOENG, JAVA Phones Holland around 9:45 a.m.</p> <p>9330 kc. CGA4 -C- 32.15 meters DRUMMONDVILLE, CANADA Phones England irregularly</p> <p>9280 kc. GCB -C- 32.33 meters RUGBY, ENGLAND Calls Can. & Egypt, evenings</p>	<p>9170 kc. WNA -C- 32.72 meters LAWRENCEVILLE, N. J. Phones England, evening</p> <p>9150 kc. YVR -C- 32.79 meters MARACAY, VENEZUELA Works with Europe afternoons.</p> <p>9125 kc. HAT4 -B- 32.88 meters "RADIOLABOR," GYALI-UT, 22 BUDAPEST, HUNGARY Sunday 6-7 p.m.</p> <p>9060 kc. TFK -C- 33.11 meters REYKJAVIK, ICELAND Phones London afternoons. Broadcasts irregularly.</p> <p>9020 kc. GCS -C- 33.26 meters RUGBY, ENGLAND Calls N.Y.C., evenings</p> <p>9010 kc. KEJ -C- 33.3 meters BOLINAS, CAL. Relays NBC & CBS Programs in evening irregularly</p> <p>8975 kc. VWY -C- 33.43 meters KIRKEE INDIA Works with England in morning</p> <p>8950 kc. HCJB -B- 33.5 meters QUITO, ECUADOR 7:30-9:30 p.m., except Monday Sun. 11 a.m.-12 n., 4-10 p.m.</p> <p>8795 kc. HKV -B- 34.09 meters BOGOTA, COLOMBIA Irregular; 6:30 p.m.-12 m.</p> <p>8775 kc. PNI -C- 34.19 meters MAKASSER, CELEBES, N.I. Phones Java around 4 a. m.</p> <p>8765 kc. DAF -C- 34.23 meters NORDEICH, GERMANY Works German Ships irregularly</p> <p>8760 kc. GCQ -C- 34.25 meters RUGBY, ENGLAND Calls S. Africa, afternoon</p> <p>8750 kc. ZCK -B- 34.29 meters HONGKONG, CHINA Relays ZBW Daily 11:30 p.m.-1:15 a.m., Mon. and Thurs. 3-7 a.m., Tues., Wed., Fri. 6-10 a.m., Sat. 6-11 a.m.</p> <p>8730 kc. GCI -C- 34.36 meters RUGBY, ENGLAND Calls India, 8 a. m.</p> <p>8680 kc. GBC -C- 34.56 meters RUGBY, ENGLAND Calls ships</p> <p>8665 kc. CO9JQ -X- 34.62 meters 4 GENERAL GOMEZ CAMAGUEY, CUBA 5:30-6:30, 8-9 p.m. daily except Sat. and Sun.</p> <p>8590 kc. YNVA -B- 34.92 meters MANAGUA, NICARAGUA 7:30-9:30 p. m.</p> <p>8560 kc. WOO -C- 35.05 meters OCEAN GATE, N. J. Calls ships irregular</p> <p>8400 kc. HC2AT -B- 35.71 meters CASSILLA 877 GUAYAQUIL, ECUADOR 8-11 p.m.</p> <p>8380 kc. IAC -C- 35.8 meters Pisa, Italy</p> <p>8190 kc. XEME -B- 36.63 meters CALLE 59, No. 517 MERIDA, YUCATAN "LA VOZ de YUCATAN desde MERIDA 10 a.m.-12 n., 6 p.m.-12 m.</p> <p>8185 kc. PSK -C- 38.65 meters RIO DE JANEIRO, BRAZIL Irregularly</p> <p>8036 kc. CNR -B- 37.33 meters RABAT, MOROCCO Sunday, 2:30-5 p. m.</p>	<p>7975 kc. HC2TC -B- 37.62 meters QUITO, ECUADOR Thurs., Sun. at 8 p.m.</p> <p>7901 kc. LSL -C- 37.87 meters HURLINGHAM, ARGENTINA Calls Brazil, night</p> <p>7880 kc. JYR -B- 38.07 meters KEMIKAWA-CHO, CHIBA- KEN, JAPAN 4-7:40 a. m.</p> <p>7860 kc. SUX -C- 38.17 meters ABOU ZABAL, EGYPT Works with Europe 4-6 p.m.</p> <p>7854 kc. HC2JSB -B- 38.2 meters GUAYAQUIL, ECUADOR 8:15-11:15 p.m.</p> <p>7799 kc. HBP -B- 38.47 meters LEAGUE OF NATIONS, GENEVA, SWITZERLAND 5:30-6:15 p. m., Saturday</p> <p>7715 kc. KEE -C- 38.89 meters BOLINAS, CAL. Relays NBC & CBS Programs in evening irregularly</p> <p>7630 kc. ZHJ -B- 39.32 meters PENANG, MALAYA Daily 7-9 a.m., also Sat. 11 p.m.-1 A.M. (Sun.)</p> <p>7626 kc. RIM -C- 39.34 meters TACHKENT, U.S.S.R. Works with Moscow early morning</p> <p>7610 kc. KWX -C- 39.42 meters DIXON, CAL. Works with Hawaii, Philip- pines, Java and Japan nights.</p> <p>7550 kc. T18WS -B- 39.74 meters "ECOS DEL PACIFICO" P. O. BOX 75 PUNTA ARENAS, COSTA RICA 6 p.m.-12 m.</p> <p>7520 kc. KKH -C- 39.89 meters KAHUKU, HAWAII Works with Dixon and broad- casts irregularly nights</p> <p>7510 kc. JVP -B,C- 39.95 meters NAZAKI, JAPAN</p> <p>7500 kc. RKI -C- 40 meters MOSCOW, U.S.S.R. Works RIM early a.m.</p> <p>7390 kc. ZLT2 -C- 40.6 meters WELLINGTON, N.Z. Works with Sydney 3-7 a.m.</p> <p>7380 kc. XECR -B- 40.65 meters FREIGHT OFFICE, MEXICO CITY, MEX. Sun. 6-7 p.m.</p> <p>7281 kc. HJ1ABD -B- 41.04 meters CARTAGENA, COLO. Irregularly, evenings</p> <p>7100 kc. HKE -B- 42.25 meters BOGOTA, COL., S. A. Tue. and Sat. 8-9 p. m.; Men. & Thurs. 6:30-7 p. m.</p> <p>7080 kc. VP3MR -B- 42.68 meters GEORGETOWN, BRI. GUI- ANA, S.A. Sun. 7:45-10:15 a.m. Daily 4:45-8:45 p.m.</p> <p>7074 kc. HJ1ABK -B- 42.69 meters CALLE, BOLIVIA, PROGRESO-IGUALDAD BARRANQUILLA, COLOMBIA Sun. 3-6 p.m.</p> <p>7030 kc. HRP1 -B- 42.67 meters SAN PEDRO SULA, HONDURAS Reported on this and other waves irregularly in evening</p> <p>6996 kc. PZH -B- 42.88 meters P. O. BOX 18, PARAMIRABO, DUTCH GUIANA Sun. 9:36-11:36 a.m. Mon. and Fri. 5:36-9:36 p.m., Tues. and Thur. 8:36-10:36 a.m., 2:36-4:36 p.m. Wed. 3:36-4:36, 5:36-9:36 p.m. Sat. 2:36-4:36 p.m.</p>
--	---	--	---	---

(All Schedules Eastern Standard Time)

6976 kc. HCETC
-B- 43 meters
TEATRO BOLIVAR
QUITO, ECUADOR
Thurs. 11:30-9:30 p.m.

6905 kc. GDS
-C- 45.45 meters
RUGBY, ENGLAND
Calls N.Y.C. evening

6860 kc. KEL
-X- 43.70 meters
BOLINAS, CALIF.
Tests irregularly
11 a.m.-12 n.; 6-9 p.m.

6850 kc. TI6OW
-B- 43.8 meters
DNDA del CARIBE
PUERTO LIMON, COSTA
RICA
Irregularly 8-9:30 p.m.

6800 kc. HI7P
-B- 44.12 meters
EMISDRIA DIARIA de COM-
ERCIO, CIUDAD TRUJILLO,
DOM. REP.
Daily exc. Sat. and Sun. 12:40-
1:40, 6:40-8:40 p.m.; Sat. 12:40-
1:40 p.m.; Sun. 10:40 a.m.-
11:40 a.m.

6780 kc. HIH
-B- 44.25 meters
SAN PEDRO de MACORIS
DOMINICAN REP.
12:10-1:40 p.m., 7:30-9 p.m.,
Sun. 3-4 a.m., 4:15-6 p.m.

6755 kc. WOA
-C- 44.41 meters
LAWRENCEVILLE, N. J.
Phones England, evening

6750 kc. JVT
-B.C. 44.44 meters
NAZAKI, JAPAN
KOKUSAI DENWA KAISHA,
LTD., TOKIO

6730 kc. HI3C
-B- 44.58 meters
"LA VOZ DE LA FERIA"
LA ROMANA, DOM. REP.
11:55 a.m.-1:25 p.m.,
6:10 p.m.-12 M.

6710 kc. TIEP
-B- 44.71 meters
LAVOZ DEL TROPICO
SAN JOSE, COSTA RICA
APARTADO 257, Daily 7-10
p.m.

6690 kc. XGOX
-B- 44.84 meters
NANKING, CHINA
6:30-9 a.m.

6672 kc. YVQ
-C- 44.95 meters
MARACAY, VENEZUELA
Broadcasts Sat. 8-9 p.m.

6650 kc. IAC
-C- 45.11 meters
PISA, ITALY
Cable ships, evenings

6635 kc. HC2RL
-B- 45.21 meters
P. O. BOX 759, GUAYAQUIL,
ECUADOR, S. A.
Sunday, 5:45-7:45 p. m.
Tues., 9:15-11:15 p. m.

6630 kc. HIT
-B- 45.25 meters
"LA VOZ DE LA RCA VICTOR."
APARTADO 1105, CIUDAD
TRUJILLO, D.R.
Daily exc. Sun. 12:10-1:40 p.m.,
5:40-8:40 p.m., also Sat. 10:40
p.m.-12:40 a.m. (Sun.)

6625 kc. PRADO
-B- 45.28 meters
RIOBAMBA, ECUADOR
Thurs. 9-11:45 p.m.

6600 kc. HI8A
-B- 45.45 meters
CIUDAD TRUJILLO, DOM.
REP.
Irregular

6558 kc. HI4D
-B- 45.74 meters
CIUDAD TRUJILLO, DOM-
INICAN REPUBLIC
Except Sun. 11:55 a.m.-1:40
p.m.; 4:40-7:40 p.m.

6550 kc. TIRCC
-B- 45.8 meters
RADIOEMISORA CATOLICA
COSTARRICENSE
SAN JOSE, COSTA RICA
Sun. 11 a.m.-2 p.m., 6-7, 8-9
p.m., Daily 12 n.-2 p.m., 6-7
p.m., Thurs. 6-11 p.m.

6545 kc. YV11RB
-B- 45.84 meters
"ECOS de ORINOCO",
BOLIVAR, VENEZUELA
6-10:30 p.m.

6520 kc. YV6RV
-B- 46.01 meters
VALENCIA, VENEZUELA
11 a.m.-2 p.m., 5-10 p.m.

6500 kc. HIL
-B- 46.15 meters
APARTADO 623
CIUDAD TRUJILLO, D.R.
12:10-1:40 p.m., 5:40-
7:40 p.m.

6477 kc. HI4V
-B- 46.32 meters
CIUDAD TRUJILLO, D.R.
LA VDZ de LA MARINA
11:40 a.m.-1:40 p.m., 5:10-9:40
p.m.

6450 kc. HJ4ABC
-B- 46.51 meters
APARTADO 39
IBAQUE, COLOMBIA
11 a.m.-12 n., 8-11 p.m.

6425 kc. W9XBS
-X- 46.7 meters
NATL. BRDAO. CO.
CHICAGO, ILL.
Relays WMAQ, Irregular

6420 kc. HI1S
-B- 46.73 meters
PUERTO PLATA, DOM. REP.
11:40 a.m.-1:40 p.m., 5:40-
7:40, 9:40-11:40 p.m.

6410 kc. TIPG
-B- 46.8 meters
APARTADO 225,
SAN JOSE, COSTA RICA
"LA VOZ DE LA VICTOR"
12 n.-2 p.m., 6-11:30 p.m.

6400 kc. YV9RC
-B- 46.88 meters
CARACAS, VENEZUELA
7-11 p.m.

6380 kc. YV4RC
-B- 47.02 meters
CARACAS, VENEZUELA
5:30-9:30 p.m.

6316 kc. HIZ
-B- 47.5 meters
CIUDAD TRUJILLO
DOMINICAN REPUBLIC
Daily except Sat. and Sun.
11:10 a.m.-2:25 p.m., 5:10-8:40
p.m.; Sat. 5:10-11:10 p.m.;
Sun., 11:40 a.m.-1:40 p.m.

6300 kc. YV12RM
-B- 47.62 meters
MARACAY, VENEZUELA
8-10:30 p.m.

6282 kc. CO9WR
-B- 47.76 meters
P.O. BOX 85,
SANCTI SPIRITUS, CUBA
4-6, 9-11 p.m.

6280 kc. HIG
-B- 47.77 meters
CIUDAD TRUJILLO, D.R.
7:10-8:40 a.m., 12:40-2:10,
8:10-9:40 p.m.

6235 kc. HRD
-B- 48.12 meters
LA VOZ DE ATLANTIDA
LA CEIBA, HONDURAS
8-11 p.m., Sat. 8 p.m.-1 a.m.
(Sun.); Sun. 4-6 p.m.

6230 kc. OAX4G
-B- 48.15 meters
Apartado 1242
LIMA, PERU
Daily 7-10:30 p.m.
Wed. 6-10:30 p.m.

6185 kc. HI1A
-B- 48.5 meters
P. O. BOX 423, SANTIAGO,
DOMINICAN REP.
11:40 a. m.-1:40 p. m.
7:40-9:40 p. m.

6175 kc. HJ2ABA
-B- 48.58 meters
TUNJA, COLOMBIA
1-2; 7:30-9:30 p.m.

6171 kc. XEXA
-B- 48.61 meters
DEPT. OF EDUCATION
MEXICO CITY, MEX.
7-11 p.m.

6170 kc. HJ3ABF
-B- 48.62 meters
BOGOTA, COLOMBIA
7-11:15 p. m.

6160 kc. YV3RC
-B- 48.7 meters
CARACAS, VENEZUELA
11 a.m.-2 p.m., 4-10:30 p.m.

6150 kc. CSL
-B- 48.78 meters
LISBON, PORTUGAL
7-8:30 a.m., 2-7 p.m.

6150 kc. CJRO
-B- 48.78 meters
WINNIPEG, MAN., CANADA
8 p. m.-12 m.
Sun. 3-10:30 p. m.

6147 kc. COKG
-B- 48.8 meters
BOX 137, SANTIAGO, CUBA
9-10 a.m., 11:30 a.m.-1:30 p.m.,
3-4:30 p.m., 10-11 p.m., 12 m.-
2 a.m.

6140 kc. W8XK
-B- 48.86 meters
WESTINGHOUSE ELECTRIC
& MFG. CO.,
PITTSBURGH, PA.
Relays KDKA
9 p.m.-1 a.m.

6135 kc. HJ1ABB
-B- 48.9 meters
BARRANQUILLA, COL., S. A.
P. O. BOX 715,
11:30 a.m.-1 p.m.; 4:30-10 p.m.

6135 kc. HI5N
-B- 48.95 meters
SANTIAGO, D.R.
6:40-9:10 p.m.

6135 kc. HJ4ABP
-B- 48.9 meters
MEDELLIN, COL.
Relays HJ4ABQ 8-11 p.m.

6132 kc. HIX
-B- 48.93 meters
CIUDAD TRUJILLO,
DOMINICAN REP.
Sun. 7:40-10:10; Daily 12:40
1:10 p.m., 4:40-5:40 p.m.;
Tues. and Fri. 8:10-10:10 p.m.

6130 kc. TGXA
-B- 48.94 meters
GIORNAL LIBERAL PRO-
GRESSISTA, GAUTEMALA
CITY, GUAT.
Heard in the evening.

6130 kc. COCD
-B- 48.94 meters
"LA VOZ DEL AIRE"
CALLE G Y 25, MEDADO,
HAVANA, CUBA
Relays CMCD 11 a.m.-12 n., 7-
10 p.m., Sun. 12 n.-4 p.m.

6130 kc. ZGE
-B- 48.94 meters
KUALA LUMPUR,
FED. MALAY STATES
Sun., Tue. and Fri.,
6:40-8:40 a. m.

6130 kc. VE9HX
-B- 48.94 meters
P.O. BOX 998
HALIFAX, N.S., CANADA
Mon.-Fri., 9 a.m.-1 p.m.,
5-11 p.m.
Fri. 1-3 p.m.; Sat., Sun. 9 a.m.-
1 p.m., 2-11 p.m.
Relays CHNS

6122 kc. HJ3ABX
-B- 49 meters
LA VOZ DE COLOMBIA
CALLE 14, No. 738,
BOGOTA, COLOMBIA
5:45-11:30 p.m.

6120 kc. W2XE
-B- 49.02 meters
ATLANTIC BROADCASTING
CORP.
485 MADISON AVE., N. Y. C.
Relays WABC, 11 p.m.-12 m.

6120 kc. XEFT
-B- 49.02 meters
AV. INDEPENDENCIA 28,
VERA CRUZ, MEX. 7:30-12 m.
11 a.m.-4 p.m., 7:30 p.m.-12 m.
Sat. also 6:30-7:30 p.m.
Sun. 11 a.m.-4 p.m., 9 p.m.-12
m.
Relays XETF

6115 kc.
-B- 49.05 meters
"RADIO PODEBRADY,"
CZECHOSLOVAKIA
Testing 2 p.m.-2 a.m.

6110 kc. VUC
-B- 49.1 meters
CALCUTTA INDIA
Daily except Sat. 3-5:30 a. m.,
9:30 a. m.-noon;
Sat., 11:45 a. m.-3 p. m.

6105 kc. HJ4ABB
-B- 49.14 meters
MANIZALES, COL., S. A.
P. O. Box 175
Mon. to Fri. 12:15-1 p. m.;
Tues. & Fri. 7:30-10 p. m.;
Sun. 2:30-5 p. m.

6100 kc. W3XAL
-B- 49.18 meters
NATIONAL BROADCASTING
CO.
BOUND BROOK, N. J.
Relays WJZ
Monday, Wednesday, Saturday,
5-6 p.m., Sun. 12 m.-1 a.m.

6100 kc. W9XF
-B- 49.18 meters
NATL. BROAD. CO.
CHICAGO, ILL.
Tues., Thurs., Fri. 12 m.-
1 a.m., 8 p.m.-11:35 p.m.,
M., W., Sat., 12 m.-1 a.m.
Relays WENR

6097 kc. ZTJ
-B- 49.2 meters
AFRICAN BROADCASTING
CO.
JOHANNESBURG, SOUTH
AFRICA.
Sun.-Fri. 11:45 p.m.
12:30 a.m. (incl. day)
Mon.-Sat. 3:30-7 a.m.,
9 a.m.-4 p.m.
Sun. 8-10:15 a.m.; 12:30-3 p.m.

6092 kc. HJ4ABE
-B- 49.25 meters
MEDELLIN, COLO.
Daily 11 a.m.-12 n., 6-10:30
p.m.

6090 kc. CRCX
-B- 49.26 meters
TORONTO, CANADA
Daily 6:30 p.m.-12:30 a.m.
Sun. 12:45 p.m.-12:45 a.m.

6090 kc. VE9BJ
-B- 49.26 meters
SAINT JOHN, N. B., CAN.
7-8:30 p. m.

6085 kc. HJ5ABD
-B- 49.3 meters
"LA VOZ DE VALLE"
CALI, COLOMBIA
12 n.-1:30 p.m., 5:10-8:40 p.m.

6083 kc. VQ7LO
-B- 49.31 meters
NAIROBI, KENYA, AFRICA
Mon.-Fri. 5:45-6:15 a.m., 11:30
a.m.-2:30 p.m. Also 9:30-9:30
a.m. on Tues. and Thurs.; Sat.
11:30 a.m.-3:30 p.m.; Sun. 11
a.m.-2 p.m.

6080 kc. CP5
-B- 49.34 meters
LAPAZ, BOLIVIA
7-10:30 p. m.

6080 kc. HP5F
-B- 49.34 meters
CARLTON HOTEL
CDLON, PANAMA
11:45 a.m.-1:15 p.m., 7:45-10
p.m.

6080 kc. W9XAA
-B- 49.34 meters
CHICAGO FEDERATION OF
LABOR
CHICAGO, ILL.
Relays WCFL
Sunday 11:30 a. m.-9 p. m. and
Tues., Thurs., Sat., 4 p. m.-12 m.

6079 kc. DJM
-B.X- 49.34 meters
BROADCASTING HOUSE,
BERLIN, GERMANY

6072 kc. OER2
-B- 49.41 meters
VIENNA, AUSTRIA
9 a. m.-5 p.m., Sat. to 6 p.m.

6070 kc. YV7RMO
-B- 49.42 meters
MARACAIBO, VENEZUELA
6 p.m.-12 m.

6070 kc. HJ4ABC
-B- 49.42 meters
PERIERA, COL.
9-11 a.m., 7-8 or 9 p. m.

6070 kc. VE9CS
-B- 49.42 meters
VANCOUVER, B. C., CANADA
Sun. 1:45-9 p.m., 10:30 p.m.,
1 a.m.-8 p.m.; Tues. 6-7:30 p.m.,
11:30 p.m.-1:30 a. m. Daily
6-7:30 p. m.

6065 kc. HJ4ABL
-B- 49.46 meters
MANIZALES, COL.
Daily 11 a.m.-12 n., 5:30-7:30
p.m. Sat. 5:30-10:30 p.m.

6060 kc. W8XAL
-B- 49.50 meters
CROSLY RADIO CORP.
CINCINNATI, OHIO
5:30 a.m.-8 p.m.; 11 p.m.-1 a.m.
Relays WLW

6060 kc. W3XAU
-B- 49.50 meters
PHILADELPHIA, PA.
Relays WCAU
8 p.m.-11 p.m.

6060 kc. OXY
-B- 49.50 meters
SKAMLEBOAEK, DENMARK
1-6:30 p.m.

6050 kc. HJ3ABD
-B- 49.59 meters
COLOMBIA BROADCASTING
BDX 509, BOGOTA, COL.
12 n.-2 p.m., 7-11 p.m., Sun.
5-9 p.m.

6045 kc. HI9B
-B- 49.63 meters
SANTIAGO
DOM. REP.
Irregular 6 p.m.-11 p.m.

6042 kc. HJ1ABG
-B- 49.65 meters
EMISORA ATLANTICO
BARRANQUILLA, COLO.
11 a.m.- 11 p.m.
Sun. 11 a.m.- 8 p.m.

6040 kc. W4XB
-B- 49.67 meters
MIAMI BEACH, FLA.
Relays WIOD 12 n.-2 p.m.,
5:30 p.m.-12 m.

6040 kc. PRA8
-B- 49.67 meters
RADIO CLUB OF
PERNAMBUCO
PERNAMBUCO, BRAZIL
1-3 p.m., 4-7:30 p.m. daily

6040 kc. W1XAL
-B- 49.67 meters
BOSTON, MASS.
Tues., Thurs. 7:15-9:15 p.m.
Sun 5-7 p.m.

6040 kc. YDA
-B- 49.67 meters
N.I.R.O.M.
TANDJONGPRIK, JAVA
10:30 p.m.-2 a.m. Sat. 7:30 p.m.,
2 a.m. (Sun.)

6030 kc. HP5B
-B- 49.75 meters
P. O. BOX 910
PANAMA CITY, PAN.
12 n.-1 p.m., 7-10:30 p.m.

6030 kc. VE9CA
-B- 49.75 meters
CALGARY, ALBERTA, CAN.
Thurs. 9 a.m.-2 a.m. (Fri.);
Sun. 12 n.-12 m.
Irregularly on other days from
9 a.m.-12 m.

6025 kc. HJ1ABJ
-B- 49.79 meters
SANTA MARTA, COLO.
6:30-10:30 p.m. except Wed.

6020 kc. DJC
-B- 49.83 meters
BROADCASTING HOUSE,
BERLIN

6020 kc. XEUW
-B- 49.82 meters
AV. INDEPENDENCIA 98,
VERA CRUZ, MEX.
8 p.m.-12:30 a.m.

6018 kc. ZHI
-B- 49.85 meters
RADIO SERVICE CO.,
20 ORCHARD RD.,
SINGAPORE, MALAYA
Mon., Wed. and Thurs 5:40-8:10
a.m. Sat. 10:40 p.m.-1:10 a.m.
(Sun.) Every other Sunday 5:10-
6:40 a.m.

6015 kc. HI3U
-B- 49.88 meters
SANTIAGO de los CABAL-
LEROS, DOM. REP.
10:40 a.m.-1:40 p.m., 4:40-
9:40 a.m.

6012 kc. HJ3ABH
-B- 49.91 meters
BOGOTA COLO.
APARTADO 565
6-11 p.m.
Sun. 12 n.-2 p.m., 4-11 p.m.

6010 kc. COCO
-B- 49.92 meters
P.O. BOX 98
HAVANA, CUBA
Daily 9:30 a.m.-1 p.m., 4-7 p.m.,
8-10 p.m.
Sat. also 11:30 p.m.-2 a.m.

6005 kc. HP5K
-B- 49.96 meters
BOX 33,
COLON, PANAMA
7:30-9 a.m., 12 n.-1 p.m.,
6-9 p.m.

6005 kc. CFCX
-B- 49.96 meters
CANADIAN MARCONI CO.,
MONTREAL, QUE.
CAN.
Relays CFCF 7 a.m.-12:15 a.m.
Sun. 10 a.m.-11:15 p.m.

6000 kc. HJ1ABC
-B- 50 meters
QUIBDO, COLOMBIA
5-6 p.m., Sun. 9-11 p.m.

5990 kc. XEBT
-B- 50.08 meters
MEXICO CITY, MEX.
P. O. Box 79-44
8 a.m.-1 a.m.

5988 kc. HJ2ABD
-B- 50.10 meters
BUARAMANGA, COL.
11:30 a.m.-12:30 p.m., 5:30-
6:30, 7:30-10:30 p.m.

<p>5980 kc. XEWI -B- 50.17 meters MEXICO CITY, MEX. Mon., Wed., Fri., 3-4 p.m. Tues., Fri. 7:30-8:45, 10 p.m.-12 m.; Sat. 9-10 p.m.; Sun. 1-2:15 p.m.</p> <p>5976 kc. HJ2ABC -B- 50.2 meters CUCUTA, COLOMBIA 6-9:30 p.m.</p> <p>5968 kc. HVJ -B- 50.27 meters VATICAN CITY 2-2:15 p. m., daily, Sun., 5-5:30 a. m.</p> <p>5950 kc. HJN -B- 50.42 meters BOGOTA, COL. 6-11 p.m.</p> <p>5940 kc. TG2X -B- 50.5 meters GUATEMALA CITY, GUAT. 4-6, 9-11 p.m.; Sun. 2-5 a.m.</p> <p>5915 kc. HH2S -B- 50.72 meters PORT-au-PRINCE, HAITI BOX A103. 7:30-10:30 p.m.</p> <p>5898 kc. YV8RB -B- 50.86 meters "LA VOZ de LARA" BARQUISIMETO, VENEZUELA 12 n. 1p.m., 6-10 p.m.</p>	<p>5885 kc. HCK -B- 50.98 meters QUITO, ECUADOR. S. A. 8-11 p.m.</p> <p>5875 kc. HRN -B- 51.06 meters TEGUCIGALPA, HONDURAS 1:15-2:15, 8:30-10 p.m., Sun. 3:30-5:30, 8:30-9:30 p.m.</p> <p>5865 kc. HI1J -B- 51.15 meters BOX 204, SAN PEDRO de MACORIS, DOM. REP. 12 n.-2, 6:30-9 p.m.</p> <p>5853 kc. WOB -C- 51.26 meters LAWRENCEVILLE, N. J. Calls Bermuda, nights</p> <p>5850 kc. YV5RMO -B- 51.28 meters CALLE REGISTRADO, LAS DE- LICIAS APARTADO de COR- RES 214 MARACAIBO, VENEZUELA 8:45-9:45 a.m., 11:15 a.m.-12:15 p.m., 4:45-9:45 p.m., Sun. 11:45 a.m.-12:45 p.m.</p> <p>5830 kc. TIGPH -B- 51.5 meters ALMA TICA, APARTADO 800, SAN JOSE, COSTA RICA 11 a.m.-1 p.m., 6-10 p.m., Relays TIX 9-10 p.m.</p>	<p>5800 kc. YV2RC -B- 51.72 meters RADIO CARACAS CARACAS, VENEZUELA Sun. 8:30 a.m.-10:30 p.m. Daily 11 a.m.-1:30 p.m., 4-9:30 p.m.</p> <p>5790 kc. JUV -C- 51.81 meters NAZAKI, JAPAN</p> <p>5780 kc. OAX4D -B- 51.9 meters P.O. Box 853 LIMA, PERU Mon., Wed. & Sat. 9-11:30 p.m.</p> <p>5770 kc. HJ4ABD -B- 51.99 meters LA VOZ CATIA, MEDELLIN, COLOMBIA 8-11:30 p.m.</p> <p>5720 kc. YV10RSC -B- 52.45 meters "LA VOZ de TACHIRA," SAN CRISTOBAL, VENEZUELA 6-11:30 p.m.</p> <p>5713 kc. TGS -B- 52.51 meters GUATEMALA CITY, GUAT. Wed., Thurs. and Sun. 6-9 p.m.</p> <p>5500 kc. TI5HH -B- 54.55 meters SAN RAMON, COSTA RICA Irregularly 3:30-4, 8-11:30 p.m.</p>	<p>5145 kc. PMY -B- 58.31 meters BANDOENG, JAVA 5:30-11 a.m.</p> <p>5077 kc. WCN -C- 59.08 meters LAWRENCEVILLE, N. J. Phones England irregularly</p> <p>5025 kc. ZFA -C- 59.7 meters HAMILTON, BERMUDA Calls U.S.A., nights</p> <p>5000 kc. TFL -C- 60 meters REYKJAVIK, ICELAND Calls London at night, Also broadcasts irregularly</p> <p>4975 kc. GBC -C- 60.30 meters RUGBY, ENGLAND Calls Ships, late at night</p> <p>4820 kc. GDW -C- 62.24 meters RUGBY, ENGLAND Calls N.Y.C., late at night</p> <p>4790 kc. VE9BK -BX- 62.63 meters RADIO SALES SERVICE, LTD., 780 BEATTY ST., VAN- COUVER, B.C., CAN. Daily exe. Sun. 11:30-11:45 a. m., 3-3:15, 8-8:15 p.m.</p> <p>4752 kc. WOO -C- 63.1 meters OCEAN GATE, N. J. Calls ships irregularly</p>	<p>4600 kc. HC2ET -B- 65.22 meters Apartado 249 GUAYAQUIL, ECUADOR Wed., Sat., 9:15-11 p.m.</p> <p>4320 kc. GDB -C- 69.44 meters RUGBY, ENGLAND Tests, 8-11 p. m.</p> <p>4273 kc. RV15 -B- 70.20 meters KHABAROVSK, SIBERIA, U. S. S. R. Daily, 3-9 a.m.</p> <p>4272 kc. WOO -C- 70.22 meters OCEAN GATE, N. J. Calls ships irregularly</p> <p>4098 kc. WND -C- 73.21 meters HIALEAH, FLORIDA Calls Bahama Isles</p> <p>4002 kc. CT2AJ -B- 74.95 meters PONTA DELGADA, SAO MIGUEL, AZORES Wed. and Sat. 5-7 p. m.</p> <p>3040 kc. YDA -B- 98.68 meters N. R. O. M. TANDJONGPURIK, JAVA Daily exe. Sat. 6-7:30 p.m., 5:30-10:30 or 11 a.m., Sat. 5:30- 11:30 a.m.</p>
--	--	---	---	---

Alphabetical List of S-W Stations

By Call-Letter and Frequency

(Frequency in Megacycles)

CALL	FREQ.	CALL	FREQ.	CALL	FREQ.	CALL	FREQ.	CALL	FREQ.	CALL	FREQ.	CALL	FREQ.
CB960	9.06 mc.	GAB	18.04	HIT	6.63	IAC	17.76 mc.	ORG	19.20 mc.	TYA	12.22 mc.	W3XAL	17.78 mc.
CEC	19.68	GAO	19.48 mc.	HIX	6.13	IAC	12.80	ORK	10.33	TYB	12.25	W3XAL	6.10
CEC	15.87	GAP	19.16	HIZ	6.32	IAC	8.38	OXY	6.06	TYF	14.64	W3XAU	9.59
CEC	10.67	GAQ	18.97	HI1A	6.19	IAC	6.65	PCJ	15.22	VE9BJ	6.09	W3XAU	6.08
CGA3	13.29	GAS	18.31	HI1J	5.86	IDU	13.39	PCJ	9.59	VE9BK	4.79	W3XL	17.31
CGA4	9.33	GAU	18.62	HI1S	6.42	(I)2RO	11.81	PCV	17.81	VE9CA	6.03	W4XB	6.04
CJA3	11.41	GAW	18.20	HI1C	6.10	2RO	9.64	POK	10.41	VE9CS	6.07	W4XC	31.60
VCJRO	6.15	GBA	13.99	HI1U	6.02	JVE	15.66	PDV	12.06	VE9DR	6.01	W4XAL	6.08
VCJRX	11.72	GBB	13.59	HI1D	6.56	JVF	15.62	PHI	17.78	VE9HX	6.13	W5XK	21.54
CNR	12.83	GBC	17.08	HI1V	6.48	JVH	14.60	PHI	11.73	VIZ3	11.56	W5XK	15.21
CNR	8.04	GBC	12.78	HI1N	6.14	JVM	10.74	PLE	18.83	VK2ME	9.59	W5XK	11.87
COCD	6.13	GBC	8.68	HI1P	6.80	JVN	10.66	PLO	11.50	VK3LR	9.58	W5XK	6.14
COCH	9.43	GBC	4.98	H18A	6.60	JVP	7.51	PLV	9.42	VK3ME	9.51	W5XWJ	31.60
COCO	6.01	GBL	14.65	H19B	6.05	JVT	6.75	PMA	19.35	VLJ	9.76	W9XAA	11.83
COCQ	9.42	GBP	10.77	HJA3	14.94	JVU	5.79	PMC	18.14	VLK	10.52	W9XAA	6.08
COGK	6.15	GBS	12.15	HJB	14.95	JYK	13.61	PMN	10.26	VLZ2	9.76	W9XBS	6.43
COJQ	8.67	GBU	12.29	HJN	5.95	JYR	7.88	PMY	5.15	VPD	13.08	W9XF	6.10
COJWR	6.28	GBW	14.44	HJU	9.50	JYS	9.84	PNI	8.78	VP3MR	7.08	XB1Q	11.20
CP5	6.08	GCA	9.71	HJ1ABB	9.56	JYT	15.76	PPU	19.26	VQ7LO	6.08	XEBT	5.99
CP5	9.59	GCB	9.28	HJ1ABC	6.0	KAY	14.98	PRADO	6.63	VR4	11.60	XECR	7.38
CQX	6.09	GCI	8.73	HJ1ABD	7.28	KAZ	9.99	PRAS	6.04	VUB	9.57	XEFT	6.12
CSL	6.15	GCJ	13.42	HJ1ABE	9.55	KEE	7.72	PRF5	9.50	VUC	6.11	XEME	8.19
CT1AA	9.65	GCQ	8.76	HJ1ABG	6.04	KEJ	9.01	PSA	21.08	VWY	8.98	XEUW	6.02
CTIGO	12.40	GCS	9.02	HJ1ABJ	6.03	KEL	6.86	PSD	15.07	VWY2	17.51	XEVI	5.98
CT2AJ	4.0	GCU	9.95	HJ1ABK	7.07	KES	10.41	PSF	14.96	WCN	5.08	XEXA	6.17
DAF	12.33	GCW	9.79	HJ1ABP	9.62	KIO	11.68	PSH	10.22	WKA	21.06	XGM	17.65
DAF	8.77	GDB	4.32	HJ2ABA	6.18	KKH	7.52	PSK	8.19	WKF	19.22	XGOX	6.69
DFB	17.52	GDS	6.91	HJ2ABC	5.98	KKR	15.46	RIM	15.25	WKK	21.42	XGW	10.42
DGU	9.650	GDW	4.82	HJ2ABD	5.98	KKZ	13.69	RIM	7.63	WKN	19.82	YBG	10.43
DJA	9.560	GEB	9.51	HJ3ABO	6.05	KTO	16.24	RIO	10.17	WLA	18.34	YDA	6.04
DJB	15.20	GSC	9.58	HJ3ABF	6.17	KWO	15.42	RIR	10.08	WLK	16.27	YDA	3.04
DJC	6.02	GSD	11.75	HJ3ABH	6.01	KWU	15.36	RKI	15.09	WMA	13.39	YDB	9.65
DJD	11.77	GSE	11.86	HJ3ABX	6.12	KWV	10.84	RKI	7.50	WMF	14.47	YDB	11.86
DJE	17.76	GSF	15.14	HJ4ABA	11.81	KWX	7.61	RNE	12.0	WMN	14.59	YNA	14.49
DJL	15.11	GSG	17.79	HJ4ABB	6.11	LKJ1	9.53	RV15	4.27	WNA	9.17	YNLF	9.65
DJM	6.08	GSH	21.47	HJ4ABC	6.45	LRU	15.29	RAN	9.60	WNB	10.68	YVC	13.35
DJN	9.54	GSJ	15.26	HJ4ABD	6.07	LRX	9.64	RAN	15.18	WNC	15.06	YVQ	6.67
DJO	11.8	GSJ	21.53	HJ4ABE	5.77	LSF	19.60	SPW	13.64	WND	4.10	YVR	18.30
DJP	11.96	GSN	11.82	HJ4ABF	6.09	LSG	19.90	SUV	10.06	WOA	6.76	YVR	9.15
DJQ	15.28	GSO	15.18	HJ4ABL	6.06	LSI	9.80	SUX	7.86	WOB	5.85	YV2RC	5.80
DJR	15.34	GSP	15.31	HJ4ABP	6.14	LSK3	10.25	SUZ	13.82	WOF	14.47	YV3RC	6.16
DZA	9.68	HAS3	15.37	HJ5ABD	6.09	LSL	15.81	TFJ	12.24	WOG	16.27	YV4RC	6.38
DZB	10.04	HAT4	9.13	HKE	9.93	LSL2	10.30	TFK	9.06	WOK	10.55	YV5RMO	5.85
DZC	10.29	HB1	14.54	HKE	7.10	LSM2	14.50	TFL	5.0	WON	9.87	YV6RV	6.52
DZE	12.13	HBL	9.60	HKV	8.50	LSN	9.89	TGF	14.49	WOO	17.62	YV7RMO	6.07
DZG	15.36	HBP	7.80	HPP	14.49	LSN	14.53	TGS	5.71	WOO	12.84	YV8RB	5.90
DZH	14.46	HCETC	6.98	HPSB	6.03	LSN5	19.65	TGW	9.45	WOO	8.56	YV9RC	6.40
EAQ	9.86	HCJB	8.95	HPSF	6.08	LSN6	21.02	TGX	6.13	WOO	4.75	YV10RSC	5.72
EDM	20.86	HCK	5.89	HPSJ	9.61	LSX	10.35	TGX2	5.94	WOO	4.27	YV11RB	6.55
EOM	10.07	H2AT	8.40	HPSK	6.01	LSY	20.70	TIEP	6.71	W1XAL	15.25	YV12RM	6.30
EHY	20.86	HC2ET	4.60	HRD	6.24	LSY3	18.12	TIGPH	5.83	W1XAL	11.79	ZBW	8.75
EHY	10.07	HC2JSB	7.85	HRF	14.49	LZA	14.97	TIPG	6.41	W1XAL	6.04	ZFA	5.03
FTA	11.94	HC2RL	6.64	HRL5	14.49	OAX4O	5.78	TIR	14.49	W1XK	9.57	ZFB	10.06
FTK	15.88	HC2RTC	7.98	HRN	5.88	OAX4G	6.23	TIRCC	6.55	W2XAD	15.33	ZGE	6.13
FTM	19.36	HH2S	5.92	HRP1	7.03	OCI	18.68	TIANRH	9.4	W2XAF	9.53	ZHI	6.02
FTO	18.25	HH3W	9.60	HS8PJ	10.96	OCI	10.97	TI5HH	5.50	W2XE	21.52	ZHJ	7.63
FZR3	16.23	HIG	6.28	HSJ	10.17	OCJ2	14.85	TIGOW	6.85	W2XE	17.76	ZLT2	7.39
FZS	14.35	HIH	6.78	HSP	17.74	OER2	6.07	TIBWS	7.55	W2XE	15.27	ZLT4	11.05
FZS2	11.99	HIJ	14.94	HVJ	15.12	OPL	20.04	TPA2	15.25	W2XE	11.83	ZSS	18.89
GAA	20.38	HIL	6.50	HVJ	5.97	OPM	10.14	TPA3	11.88	W2XE	6.12	ZTJ	6.10

"WHEN TO LISTEN IN" Appears on Page 445

Short Wave

● Because the amount of work involved in the drawing of diagrams and the compilation of data, we are forced to charge 25c each for letters that are answered directly through the mail. This fee includes only hand-drawn schematic drawings. We cannot furnish "picture-layouts" or "full-sized" working drawings. Letters not accompanied by 25c will be answered in turn on this page. The 25c remittance may be made in

EDITED BY GEORGE
W. SHUART, W2AMN

the form of stamps, coin or money order.

Special problems involving considerable research will be quoted upon request. We cannot offer opinions as to the relative merits of commercial instruments.

Correspondents are requested to write or print their names and addresses clearly. Hundreds of letters remain unanswered because of incomplete or illegible addresses.

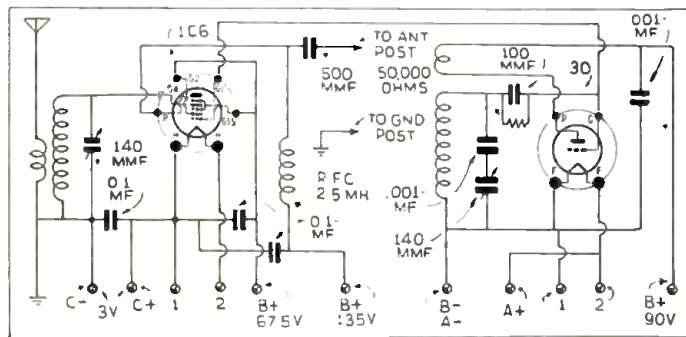

Battery operated converter (1001)

2-TUBE DX'er

Kaye Palmer, New York City.

(Q) Would you please reprint the diagram of the 2-tube DX'er which was described in the July, 1934 issue of *Short Wave Craft*?

(A) The diagram of the "2-tube DX'er" is shown herewith. Regeneration is controlled by a 50,000 ohm variable resistor connected across the tickler winding. It may be well to experiment with the plate voltage applied to the detector inasmuch as some tubes may require different voltages. The voltage giving smoothest control of regeneration should be employed.

(Q) I have a broadcast receiver to which I would like to attach a short-wave converter employing 2-volt battery type tubes. I would very much like to see the diagram printed in *Short Wave Craft*. Kindly give all details showing connections to the broadcast set.

(A) In the diagram we have shown a 1CG as the detector and a type 30 as the oscillator. This combination makes a very stable and efficient converter system and simplifies the matter of injecting the oscillator voltage into the detector circuit. The diagram also shows how the converter is coupled to the receiver.

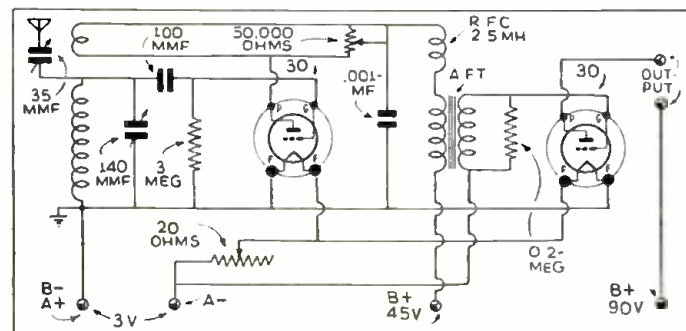

The famous 2-tube DX'er (1002)

BATTERY OPERATED CONVERTER

Leo Knight, W. Union, W. Va.

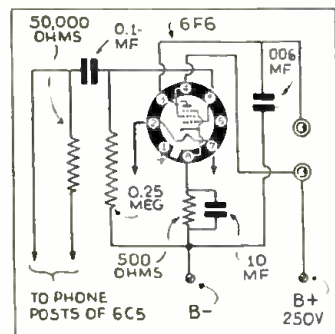

Pentode A.F. Amplifier (1003)

6F6 AMPLIFIER

Edward Ancell, Higbee, Missouri.

(Q) I intend to build the high-gain "Metal 2" receiver described in the August, 1936 issue. Would you please be kind enough to print in the "Question Box" a diagram of a pentode amplifier using a metal tube, which would be added to the above receiver? This must be simple and inexpensive.

(A) The pentode amplifier which may be added to the high-gain "Metal 2" receiver is shown. Resistance coupling is employed. This should permit speaker operation when used with the 2-tube receiver.

RADIO CONTROL

Eugene Sullivan, Fresno, Calif.

(Q) In one of the past issues of *Short Wave Craft* I remember seeing a method described which controlled model boats. Would you please let me know which issue this was?

(A) See page 472, Dec. 1934 issue for details of such a system.

1-TUBE XTAL TRANSMITTER

Bob Langley, Larkspur, Calif.

(Q) I would like to build a 1-tube crystal controlled transmitter using a type 10 tube. Would this be suitable for CW operation on the 80-meter band? Please print the diagram if it will work out o.k.

(A) We recommend that you use a 47 in place of the 10; although this is a receiving tube and considerably lower priced than a 10, it will make a very much better oscillator. The diagram is shown together with all data which are necessary for operation on the 80-meter band. The crystal, of course, would be resonant in that band.

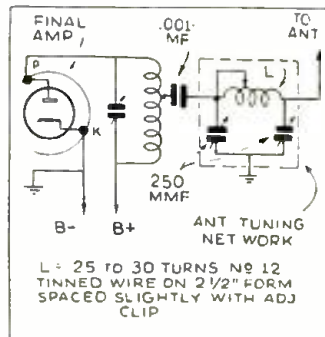

Antenna-tuning "network" for the "Ham." (1006)

ANTENNA NETWORK

Buddy Yerlow, New York, N.Y.

(Q) I would like to have information on an antenna coupling arrangement which may be used to couple any antenna to a transmitter. I understand this eliminates the necessity of putting up a special aerial.

(A) It is quite true that with the impedance matching network, shown in the diagram, any type of antenna may be coupled to a transmitter and a fairly efficient match obtained. However, better results may be experienced if a conventional antenna is used in conjunction with this network.

For push-pull amplifier circuits two coils will be used with the condensers in the same positions. By using the two coil arrangement with the push-pull stage, it is much easier to feed antennas with two wire R.F. transmission lines or feeders such as the Zeppelin or 2-wire matched impedance coil. With the two-coil method, the condensers may have split stators with the rotors grounded.

POWER SUPPLY DIAGRAM

Wm. Ball, Salisbury, Conn.

(Q) I have a 300-volt C.T. power transformer with filament windings as follows: 2.5, 1.5, 5, and 5 volts. Would you print a diagram in the "Question Box" of a suitable power supply using this transformer?

(A) We have printed the diagram as you request and have marked the transformer 150 volts each side of center tap.

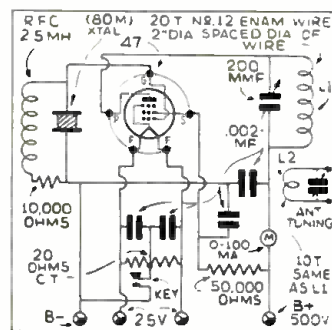

1-Tube xtal transmitter (1004)

NEEDS GOOD ANTENNA

Sidney Hoffman, South Fallsburg, New York.

(Q) I have been looking through many magazines but failed to find an antenna which I felt would be suitable for my particular location. I would like to know if you could provide some information on the subject.

(A) Short Wave Antennas have been discussed frequently in *Short Wave Craft*. Nearly every issue contains information on it. For an especially interesting article we refer you to page 714 of the April, 1935 issue. This article involves a tuned system which gives excellent results.

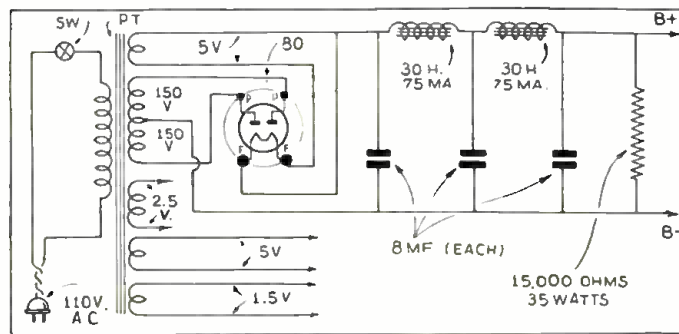

Power-supply for all types of S-W receivers (1005)

QUESTION BOX

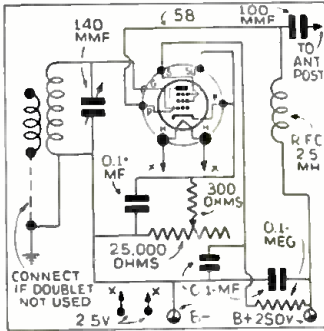

R.F. amplifier diagram (1007)

BOOSTER FOR BATTERY SET

Paul MacArthur, Toledo, Ohio.

(Q) I have a battery type receiver which performs excellently. However, I would like to boost the weaker signals so that they could be more comfortably distinguished. Would you please tell me how this can be done? I have been informed that another tube may be added. Also, will this increase the selectivity?

(A) We have shown a diagram of a type 34. This may be employed as a tuned R.F. booster stage for your receiver. While this will increase the sensitivity considerably, we doubt if it will effect the apparent selectivity. It might be advisable to incorporate a small variable condenser in series with the antenna connected to this stage

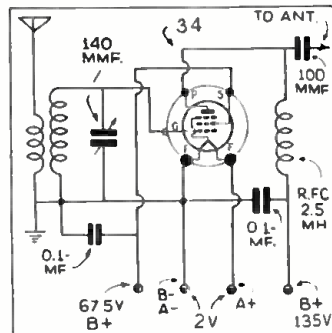

Booster for battery set (1008)

so that coupling could be reduced in order to cope with congested bands.

COMING—3 BIG FEATURES!

A "full-fledged" 5-meter Superheterodyne of improved design.

A 1937 "Desk-Type" Transmitter, covering all bands from 80 to 5 meters.

By George W. Shuart, W2AMN

2 Volt A.V.C. Superhet
By Harry D. Hooton

58 R.F. AMPLIFIER

E. C. Pritchard, Birmingham, Ala.

(Q) Would you please publish in the "Question Box" a diagram of a radio frequency amplifier employing a 58 tube and standard 2-winding coils tuned with a 140 mmf. condenser? Also indicate how this amplifier may be connected to the power supply of my present receiver.

(A) The diagram requested is shown. The B plus and B minus connect to the power supply B plus and B minus terminals and the 212-volt connections go to the filament circuit. Connections are shown for either a doublet or Marconi type antenna system.

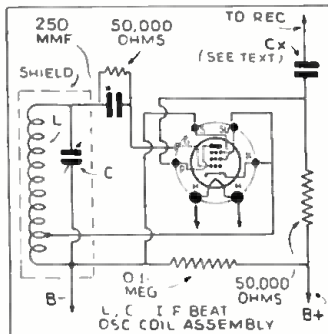

I.F. beat oscillator for superhets (1009)

I. F. BEAT OSCILLATOR

Harry Scott, Dallas, Texas.

(Q) I have a superheterodyne receiver which does not employ a beat oscillator. As such an accessory makes it considerably easier to locate stations and also permits CW reception, I would like to add it to this set. Will you please print a diagram showing the necessary parts?

(A) The diagram of a beat oscillator using a standard coil and condenser assembly is illustrated. The condenser CX depends upon the type of coupling used between the oscillator and the set. If the output of the oscillator is loosely coupled to the grid of either the second detector or the last I.F. stage, then condenser CX should have a capacity of about 100 mmf., and the insulated lead from it should be placed in the vicinity of the grid connected to the tube. By adjusting this spacing between the grid and the coupling wire, proper results will be obtained.

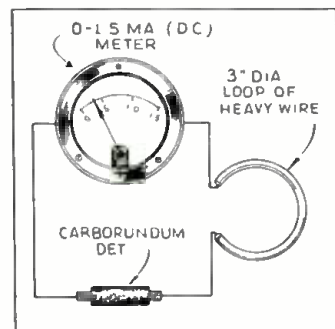

R.F. pickup meter (1010)

TUNING INDICATOR FOR XMITTER

John Richardson, Kansas City, Mo.

(Q) Many times I have heard about using a crystal detector on a milliammeter as an aid in tuning and neutralizing transmitters. Will you be kind enough to illustrate in your Question Box just how this is accomplished?

(A) The diagram shows that the 0 to 1.5 ma. meter is connected in

series with a 3 inch loop of wire and a carborundum detector. Merely couple the loop to the coil in the transmitter which you desire to analyze. Care should be taken not to have the coupling too close, otherwise it is possible for the meter to burn out. A device of this kind is exceptionally valuable when neutralizing various amplifier stages of a transmitter.

POWER SUPPLY PROBLEM

Ed. Beck, Tulsa, Okla.

(Q) I have a power supply which delivers 250 volts, and I would like to know how I might reduce this to various values down to 45. Would you please be kind enough to illustrate the answer in your Question Box?

(A) We presume that your power supply already has a bleeder resistor but it is not used as a voltage divider. What is required is a resistor with various taps on it such as illustrated in the diagram. This is known as a voltage divider and also serves as a bleeder. It may be found necessary in some cases to by-pass each tap on the voltage divider with a .1 mf. condenser. Remove the present resistor from the power supply.

ADDING R.F. STAGE

Ira Mayfield, Baton Rouge, La.

(Q) I've been using a 3-tube receiver which employs two 76's and

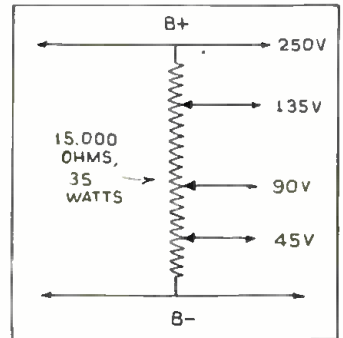

Voltage divider system (1011)

(A) Almost any 4-tube receiver will bring in the stronger stations with sufficient volume to work a speaker. Of course, full speaker volume cannot be expected on these sets.

Only the regenerative short wave receivers employing two stages of A.F. with R.F. amplification ahead of the detector may be expected to provide fair speaker volume. Superheterodynes employing 5 or 6 tubes usually require only one stage of audio. In this case the pentode will provide sufficient volume for the speaker. The average 2 or 3-tube set does not provide satisfactory all-around speaker operation.

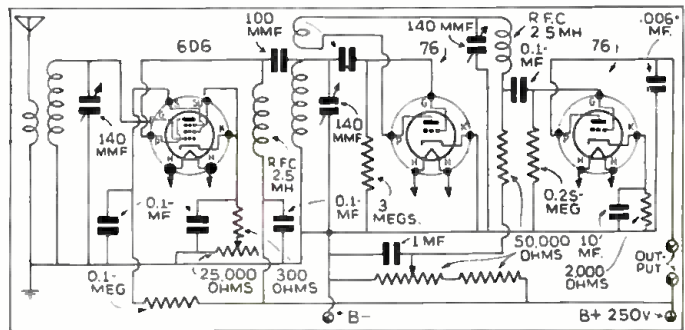

T.R.F., Det., and 1 stage A.F. (1012)

one 80. I would appreciate it very much if you could publish a diagram showing how an R.F. amplifier could be added in order to improve the selectivity and sensitivity.

(A) We are showing the diagram of the two 76's to which has been added a 6D6 R.F. amplifier. This will improve the sensitivity considerably but the apparent selectivity will remain unchanged.

6.3V. 3-TUBER

Ham Reader, New York City.

(Q) Please print a diagram of a 3-tube T.R.F. receiver using a 6D6, 6C6, and 76. This should have electron coupling in both the R.F. and detector stages. Also, what size band-spread condenser should be used for 40-meter amateur work?

(A) We presume that by electron coupling in both stages you mean to employ regeneration in the r.f. stage. The diagram shows how this is accomplished. It will require two regeneration control potentiometers for proper results. We recommend a 20 mmf. condenser shunted across the 140 mmf. condenser. The smaller condensers are used for band spread tuning.

WILL SET WORK SPEAKER?

Robert Dykton, St. Louis, Mo.

(Q) In the August, 1934, issue of Short Wave Craft, you described the "4-tube Spare Explorer." Will this set bring in foreign stations on the loudspeaker?

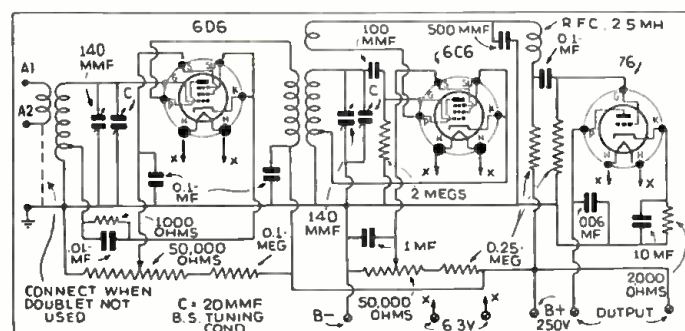

3-tube receiver using 6.3 V. tubes (1013)

SHORT WAVE LEAGUE • • •

HONORARY MEMBERS

- Dr. Lee de Forest
- John L. Reinartz
- D. E. Replogle
- Hollis Baird
- E. T. Somers
- Baron Manfred von Ardenne
- Hugo Gernsback
Executive Secretary



YDB, VK2ABD, VK3MR, VK2NO, VK2A1, VK2LP and PY2BA.

Would like very much to hear from my new friends of *Short Wave Craft*, "foreign" and U. S. Best of luck and lots of rare DX to all my S.W.C. friends.

Samuel Solito,
Leetsdale, Pa.

Official Listening Post Report of
Fletcher W. Hartman, South
Amboy, N. J.

● AMONG the more important stations heard the past month were: (E.S.T. is used throughout.)

LSX—10,350 kc., Buenos Aires, Argentina, S.A., heard at 6:20 p.m. Testing, good.

COCQ—Havana, Cuba, on about 9650 kc. has been heard as early as 7:45 a.m. broadcasting music. It is heard regularly after 6 p.m.

HBJ—14,535 kc., Geneva, Switzerland, was

Short-Wave Scout Reports

Report from Penna. Trophy Winner
● HERE is my report for this month. Reception on the 19, 25, and 31-meter band has improved since the last month. Many new stations are now heard on 31 meters, that previously were tuned in on the 19 meter band. A new station has made its appearance, "Radio Podebrady," QSA5R6 in Prague, Czechoslovakia on 15,230 kc, on July 24th from 11:10 to 11:28 p.m., E.S.T. They have no call, but announce as "Radio Podebrady." They announced that they were also testing on 11,760 kc and 6,115 kc, changing from one frequency to the other every half hour. However, I did not hear them on the other frequency.

German stations have been coming in almost R9 plus: DJB, 15,200 kc; DJQ, 15,280; DJD, 11,770 kc; DZC, 10,290 kc;

DJA on 9,560 kc; and DJN on 9,540 kc can be heard every night from 5:00 to 10:30 p.m. with programs for North and South America.

DJL on 15,110 kc., QSA5R9, testing with New York sent special to N.B.C. Aug. 12th from 4:45 to 5:15 p.m.

LZA on 14,970 kc., Radio Garata, Sofia, Bulgaria, heard Sept. 25th from 1:30 to 2:00 a.m. QSA5R5-6.

I2RO4 on 11,810 kc., Rome, is now heard every night from 6:00 to 7:30 p.m. with excellent signal.

HJ1ABE on 9,500 kc., Cartagena, tests on new frequency from 8:00 to 10:00 p.m. testing new X-mitter.

HJ2ABC on 9,575 kc., Cucuta, heard testing July 28th from 12:00 midnight to 1:00 a.m. QSA5R7.

TIPG has also moved to 9,550 kc., and can be heard testing as late as 11:30 p.m.

TGW on 9,450 kc., Guatemala, again heard broadcasting on Sunday, Aug. 9th from 1:00 to 2:00 a.m. QSA5R8. (They ask for reports and promise to verify all reports.)

YV7RMO on 6,070 kc., Maracaibo, Ven., heard July 30th from 9:46 to 9:53 p.m. QSA5R8.

HP5K on 6,005 kc., Colon, heard July 30th from 9:54 to 10:05 p.m. QSA5R7.

RAN, Moscow, is now on 9,600 kc., having changed from 9,520 kc. Heard Aug. 3rd from 7:00 to 8:00 p.m. and asking for reports. QSA5R7.

T14NRH, on 9,720 kc., Heredia, heard Aug. 3rd from 9:30 to 10:00 p.m. asking for reports. QSA5R7-8.

HBJ on 14,535 kc., Geneva, testing with New York, Aug. 4th, from 6:30 to 7:00 p.m. QSA5R8.

JVE on 15,660 kc., Nazaki, calling Manila, Aug. 8th from 6:15 to 6:39 a.m. QSA5R6-7.

PLP on 11,000 kc., Bandoeng, relaying NIROM program, Aug. 16th, from 7:00 to 7:45 a.m. QSA5R6-8.

New 20-meter phones include, LUSAN, 14,370 kc.; PY2CK, 14,100; PY2EJ, OA4AI, 14,005; CE3AG, 14,320 kc.; CX1AA, 14,270 kc.; VP3BG on 14,370 kc. and YV5AA on 14,090 kc.

Veris received include:

Here's Your Button

The illustration here-with shows the beautiful design of the "Official" Short Wave League button, which is available to everyone who becomes a member of the Short Wave League.



The requirements for joining the League are explained in a booklet, copies of which will be mailed upon request. The button measures 3/4 inch in diameter and is inlaid in enamel—3 colors—red, white, and blue.

Please note that you can order your button AT ONCE—SHORT WAVE LEAGUE supplies it at cost, the price, including the mailing, being 35 cents. A solid gold button is furnished for \$2.00 prepaid. Address all communications to SHORT WAVE LEAGUE, 99-101 Hudson St., New York.

heard on July 21, sending a special program to the U. S. at 2:45 p.m.

DJL—15,110 kc., Berlin, Germany, was heard from August 1st to 16th at 6 p.m. Broadcasting Olympic games reports to the U. S.

Radio Podebrady—6,115 kc., Praha, Czechoslovakia, was heard at 9 p.m. Testing, it had a good signal, but an American station came on at 9:10 and ruined the reception of it. English was used as well as a "foreign" tongue. This station is also supposed to broadcast on 19 meters or 15 meg. band.

HBO—11,390 kc., Geneva, Switzerland, was broadcasting a special program at 8 p.m.

HI1X—San Pedro de Macoris, D.R. on about 6,300 kc., was heard on Aug. 12th at 7:35 p.m. with a fair signal.

HJ1ABE—9,600 kc., Cartagena, Colombia, was heard on Aug. 13th at 7:38 p.m. with a good signal. It announced itself as being on 9,600 kc.

HIN—Ciudad Trujillo, D.R. On about 6,250 kc. was heard on Aug. 13th. Testing, from 8:37 to 9:05 p.m. and announced as "The Voice of the Dominican Republic." It had a very good signal. At 9 p.m. it called a U. S. Amateur phone station.

LRU—15,280 kc., should be addressed as Editorial Haynes Ltd., CALLE MAIPU 555, Buenos Aires, Argentina, S.A. (It uses 5 kw.)

There were about 70 stations heard, but the above were the more important. Veri card received from LRU.

Fletcher W. Hartman,
365 John Street,
South Amboy, N.J.

(Continued on page 442)

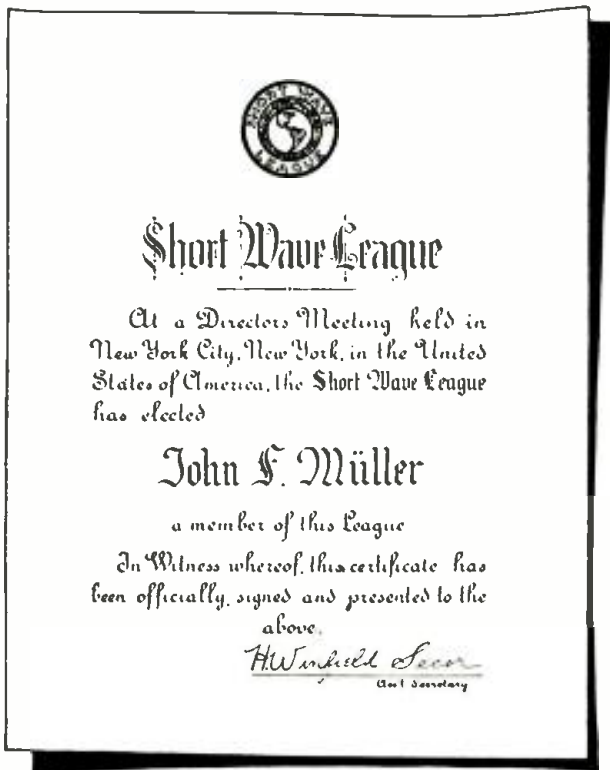

This is the handsome certificate that is presented FREE to all members of the SHORT WAVE LEAGUE. The full size is 7 1/4" x 9 1/2". see page 448 how to obtain certificate.



Eilen "MULTI-WAVE"

DeLuxe 5 Tube Regenerator
2 1/2 to 3,000 Meters

A startling new development in short wave receivers. Now, for the first time, the short wave fan is offered a really efficient, sensitive, and compact receiver covering all wavelengths between 2 1/2 and 3,000 meters, using the highly efficient interchangeable inductor system. **BANDSPREAD TUNING** on all wavelengths.

Signals from all parts of the world—powerful transatlantic and ship long wave stations—regular broadcast land stations—police calls, amateurs, experimental and regular foreign as well as domestic short wave transmissions AND the newly developed 2 1/2 to 10 meter region with its host of amateur, television and experimental stations—all pair in with great loudspeaker volume and remarkable regularity. The multi-wave regenerator has been designed so as to be extremely simple in operation. Even the beginner can operate it to complete satisfaction.

Uses five of the high gain type of tubes—6D6, 76, 76, 42, 6Z4 in hi-gain RF amplifier, electron coupled regenerative detector, **POWERFUL** two stage fidelity audio frequency amplifier with pentode output stage delivering 3 watts of audio power to the built-in hi-fidelity dynamic speaker. Full wave rectifier and built-in HUM-FREE power supply. Operates entirely from your AC 100 to 130 volt AC house current.

On wavelengths below 15 meters. The extremely sensitive super-regenerative principle is automatically employed. All of the five tubes are used at once regardless of the wavelength being used. This unit makes an ideal amateur communications receiver. Entire unit is finished in beautiful chrome plated chassis and black shirvel finished metal cabinet. Illuminated airplane type vernier dial.

EILEN "MULTI-WAVE" REGENERATOR, wired, COMPLETE, READY TO USE, including cabinet, 5 matched RCA tubes & coils for 2 1/2 to 3,000 meters, and simple instructions, less extra coils. **\$19.95**

- (2) Broadcast band coils, 200-600 meters, extra..... \$1.25
- (2) Long wave coils, 600-3,000 meters, extra..... \$1.45
- SPECIAL: EILEN MULTI-WAVE REGENERATOR KIT, cabinet, coils for 2 1/2 to 200 meters, speaker, and simple instructions, less tubes, un-wired.** **\$14.95**
- Set of 5 matched RCA tubes, extra..... \$2.90
- If metal tubes are desired, add \$1 to above prices.

Eilen

RX-14

6-Tube TUNED RADIO FREQUENCY Bandsread Receiver

8 1/2 to 3,000 meters

See editorial article and comment p. 151 July issue S.W.C.

Our largest, finest, and most sensitive short wave receiver, unequaled in appearance, performance, and value. Uses a special, highly efficient and selective circuit which will satisfy even the most discriminating short wave fan.

POWERFUL 3 stage audio amplifier with novel pentode output stage delivering 3 watts of audio power to the built-in dynamic speaker, rectifier and complete built-in power supply. HUM-FREE in operation. Automatic phone jack—BANDSPREAD TUNING—noise suppressor—connections for either doublet or single wire aerial and ground—smooth and noiseless volume and regeneration controls—powerful high fidelity audio system—large illuminated airplane vernier dial—beautiful, black shirvel finish metal chassis and cabinet with hinged lid of rare beauty—sensitivity, volume, and selectivity that only a TUNED RF stage ahead of a TUNED detector can afford.

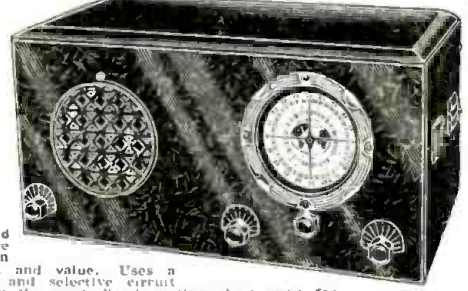

- RECEIVER, complete, wired and tested, READY TO USE, with 6 RCA glass or metal if preferred tubes, cabinet, 8 low-loss silver plated coils for 8 1/2 to 200 meters, and simple 8-page instruction booklet, less extra coils.** **\$21.75**
- Broadcast band coils (2), extra..... \$1.45
- Long wave coils, 600-3,000 meters, extra..... \$1.45
- SPECIAL: KIT of all necessary parts, unwired with speaker, 8 coils for 8 1/2-200 meters and simple wiring instructions, less cabinet, tubes, and extra coils.** **\$13.95**
- COMPLETE KIT, cabinet, with speaker, 6 RCA matched tubes, 8 coils for 8 1/2-200 meters, and simple instructions, unwired, less extra coils.** **\$18.95**

AMATEURS: Model RX-14-AM COMMUNICATIONS RECEIVER has same specifications as RX-14 except that it is equipped with special coils for 20-40-80-160 M amateur bands which spread these bands over 90 to 80% of dial scale. Also equipped with plate voltage cut-off switch for use during transmitting periods. An ideal receiver for amateur communication work. Add \$1 to price of RX-14.

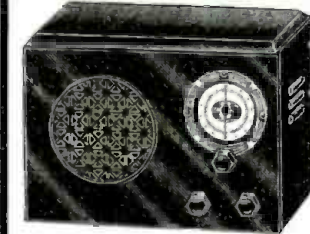

Eilen 7C 5-Tube Short Wave Receiver
8 1/2 to 625 meters

Bigger and More Powerful Than Ever A Giant in Performance

FULL 5-TUBE PERFORMANCE plus THE NEW K12A SERIES TUBE adds an outstanding value. Equipped with a powerful 3 stage audio frequency amplifier which takes the guesswork out of so-called "loudspeaker" reception.

Uses 6D6-6F7 (twin 2 in 1 tube)—7C—K12A-12A7 (twin tube) tubes as RF amplifier, screen grid regenerative detector, powerful 3 stage audio amplifier with pentode output stage, rectifier and complete built-in power supply. Completely self-contained. Nothing else required. Operates entirely from 100 to 130 volt AC or DC light socket.

BAND SPREAD TUNING—smooth regeneration control—built-in high quality loudspeaker—automatic headphone jack—large, illuminated airplane type vernier dial—large 3 winding low-loss inductance—selectivity, sensitivity, and volume that will amaze you. Heavy, black shirvel finish metal chassis and cabinet. Must be seen to be appreciated. Satisfied owners report as high as 35 foreign countries on the loudspeaker with this model. You may do the same under fair conditions. ORDER YOURS TODAY! YOU WILL NOT REGRET IT!

- EILEN 7C RECEIVER, wired, in cabinet, complete, ready to use, with speaker and 5 RCA matched tubes, 6 coils for 8 1/2 to 625 meters, and simple instructions.** **\$14.50**
- 7C KIT, unwired, of necessary parts, 4 coils for 8 1/2 to 200 meters, and instructions, less cabinet, speaker, tubes and extra coils.** **\$7.25**
- Beautiful metal cabinet, extra..... \$1.25
- 5 matched RCA tubes..... \$3.15
- Special loudspeaker..... \$1.45
- (2) Broadcast band coils, 200-625 meters..... \$1.25
- Labor for wiring & testing, extra..... \$1.75
- SPECIAL: COMPLETE KIT, unwired, cabinet, 5 tubes, speaker, 6 coils for 8 1/2 to 625 meters, and simple instructions.** **\$12.75**

AMATEURS: Model 7C All has same specifications as 7C except that it has special tuning circuit and coils for spreading out the 20-40-80-160 M. bands over 80% of dial scale. Also equipped with plate voltage cut-off switch. Same price as model 7C.

Model 6B of 6B-AB battery model of 7C using 24-10 (twin 2 in 1)—30-35 tubes. Operates from inexpensive dry batteries, same price as electric model.

Eilen

BS-5

5-Tube Band switch Receiver

12 to 600 meters

A powerful, sensitive, and selective SW receiver covering the entire wave-length span of 12 to 600 meters in 5 steps. NO PLUG-IN COILS are used. Simply turn the waveband selector switch and enjoy reception on any wavelength within this range.

Uses two 6D6, one 76, one 13, and one 1Z5 tubes as RF amplifier, electron coupled screen grid regenerative detector, powerful 2 stage audio amplifier with pentode output stage, rectifier, and complete built-in power supply.

HUM-FREE—Hi-fidelity dynamic loudspeaker—illuminated, airplane type vernier dial—band spread tuning control—automatic headphone jack—extremely smooth acting controls—operates from your AC or DC house current—beautiful, heavy, black shirvel finish chassis and cabinet.

DELIVERS GREAT LOUDSPEAKER VOLUME ON THE GREAT MAJORITY OF SHORT WAVE FOREIGN STATIONS UNDER FAIR CONDITIONS.

- PRICE, complete with 5 tubes, cabinet, speaker, wired, ready to use.** **\$16.95**
- BS-5 KIT, of necessary parts, including speaker and detailed instructions, less tubes, cabinet, unwired.** **\$10.95**
- SPECIAL: Complete kit, cabinet, tubes and instructions, unwired.** **\$14.95** (If metal tubes are preferred to glass type, add \$1)



Eilen 3A 3-Tube SW Receiver
9 1/2 to 600 meters

A simple and efficient short wave model, inexpensive in price but a wizard in performance. Use three tubes in a special ultra-sensitive regenerative circuit with one stage of audio amplification and complete built-in power supply.

- Vernier dial for easy tuning.
- Good volume on all stations.
- Small, compact, and light in weight.
- Operates from your AC or DC house current.
- Black, crackle finish metal chassis, panel, & cabinet.

- Eilen 3A KIT, of necessary parts, including coils for 9 1/2 to 200 meters, and simple instructions, less cabinet, tubes, B.C. coils, unwired.** **\$4.95**
- Beautiful, crackle finish cabinet, extra..... \$1.25
- Set of MATCHED tubes, extra..... \$1.14
- SPECIAL: Complete kit, cabinet, tubes, and instructions, less B.C. coils, unwired.** **\$7.25**
- Labor for wiring and testing, extra..... \$1.50
- 2 Broadcast band coils, extra..... \$1.25

MODEL 3B 3-TUBE BATTERY OPERATED RECEIVER
9 1/2 to 600 meters
AN IDEAL SUMMER PORTABLE
Same specifications as model 3A except that it uses 3 of the 2 volt battery operated tubes in a highly efficient circuit as regenerative detector and 2 stage audio amplifier. Same price as 3A.

Eilen Two-Tube Short Wave Radio only \$3.00



less tubes, phones, unwired

See article P. 216 August Issue S.W.C.

A REAL, powerful 2 tube short wave set readily brings in amateurs, police calls, broadcast stations, experimental and foreign stations under any conditions. **THE WORLD AT YOUR DOOR!**

A DEFENDABLE RECEIVER which is guaranteed to give results. Operates entirely from the AC or DC house current, simple to build and easy to operate. Beautiful, black shirvel finished cabinet and instructions furnished. Wavelength range 10 to 600 meters.

- TWO TUBE BATTERY SET, less tubes, phones, batteries, unwired.** **\$2.00**
- Kits wired, extra \$0.75. Tubes, each..... \$0.50**
- Cannonball double headphones..... \$1.35**

FREE: Large, illustrated catalogue of short wave receivers, transceivers, transmitting apparatus, and accessories. Send stamp to cover mailing costs.

Eilen HF-35 3-Tube SW Transmitter



A powerful and well engineered amateur band transmitter of great beauty and efficiency—**ATA PRICE WITHIN THE AMATEUR'S REACH.** Uses 50-10-40 tubes as TRIFRET CRYSTAL CONTROLLED OSCILLATOR—CLASS C RF POWER AMPLIFIER—built-in antenna tuning system—beautiful, black shirvel metal case and shelving—Triplet meters—Eilen transmitting dials—highest quality construction—35 watts of power output on 20-40-80-160 M bands. A transmitter that you can be proud to own. An excellent exciter unit for high power stages to be added later. 4 coils for any 1 band and instructions included.

- HF-35, assembled, and ready to wire (less tubes, power supply, crystal, holder and additional coils).** **\$21.95**
- Matched Arcturus Tubes..... \$2.15
- Eilen quartz crystal 180 or 160..... \$1.95
- Eilen crystal holder..... \$1.00
- Coils for additional bands, per set..... \$1.45
- HV-475 1-Tube power supply for use with HF-35, less tube \$12.95 (ready to wire).** Labor for wiring extra \$1.00
- 83 tube for HV-175, extra 65 cents
- M-15 3-Tube Modulator for use with HF-35 and capable of modulating its entire output at 100%, priced at (less tubes)..... \$14.95**
- Three Arcturus tubes, 50-53-53, extra..... \$1.95

EILEN RADIO LABORATORIES, Dept. SC 11, 136 LIBERTY STREET, NEW YORK, N. Y.

Please mention SHORT WAVE CRAFT when writing advertisers

NEW!!

DIFFERENT!...

BETTER!!

2 1/2 TO 3000 METERS

FULL BAND-SPREAD



SEVEN TUBE
●
TUNED R.F. STAGE
●
NOISE SUPPRESSOR

The Ace Do-all DeLuxe

LOOK AT THESE FEATURES:—

- **TUBE LINE-UP:** 6K7 (all metal) tuned high gain pre-selector stage—6K7 electron coupled regenerative detector—76 U.H.F. 2 1/2 to 10 meter Super-regenerative detector—76-76-12 High Fidelity THREE STAGE audio frequency amplifier with three watts actual output—5Y4 Full-wave, high voltage full power rectifier. **TOTAL—SEVEN FULL DUTY TUBES!!**
- **TUNED RADIO FREQUENCY STAGE—**A positive essential for sharp selectivity.
- **RANGE:** 100 Ke to 120 Mc. Continuous—no skips!
- **DUPLEX REGENERATION CONTROL:** Semi-Automatic keeps detector action at peak sensitivity—manual control for setting.
- **FULL BANDSPREAD:** Two new Transmitter type dials with built-in dual steel friction drive give positive, velvet smooth control and full spread of all bands.

- **NOISE SUPPRESSOR:** Built-in, switch controlled device markedly decreases interfering noises.
- **AND—**Self-contained, full floating high fidelity dynamic speaker—Single wire or doublet antenna input—R.F. gain control—Headphone jack with automatic speaker cut-out—Built-in power supply. Humless high voltage type for AC operation only—Calibration curves mounted on front panel—Smart, professional satin aluminum finish—Provision for standard 8 3/4" x 1 1/2" relay rack mounting—All metal tubes in R.F. circuits give complete shielding and greater sensitivity. (All glass tubes, if preferred, supplied at same price)
- Dual indirect panel illumination—Attractively finished, durable cabinet for table or rack mount—Extreme simplicity of operation—Six page instruction, diagram, and tuning booklet—etc., etc.

This is the famous Do-All DeLuxe Receiver that has amazed the entire Short Wave World by its remarkable performance! With this receiver in your "shack" watch your DX catches, QSO's, and your veries grow by leaps and bounds. Other set owners simply have to take a back seat!

The Do-All DeLuxe is new! It's different! It's better! And—it costs less!

The Do-all DeLuxe is the only receiver that incorporates all of these important advancements toward better, easier, POSITIVE RECEPTION OF FOREIGN BROADCAST!

This is the receiver that will DO-ALL—and more—than higher priced sets can do. It is honestly the best value ever offered to the Short Wave Fan and the Amateur! Order yours today and be convinced!

DO-ALL DELUXE STANDARD MODEL (9 to 3000 Meters)
Six tube Receiver, complete with matched tubes, and cabinet. Nothing else to buy! (Not wired) **\$1975**

Laboratory wired and tested. Ready for you to attach antenna, plug into socket, and thrill to new and strange programmes! Price..... **\$2175**

If tubes, cabinet, and 200 to 3000 meter wavelength range are not desired at present you may deduct from the above prices..... **\$500**

DO-ALL DELUXE ULTRA MODEL (2 1/2 to 3000 Meters)
Seven tube Receiver, complete with matched tubes and cabinet. Ready to be wired. **\$2375**

Laboratory wired and tested, ready to operate. The entire world of Radio at your command! Complete **\$2625**

If tubes, cabinet, and 200 to 3000 meter wavelength range are not desired at present you may deduct from the above prices..... **\$500**

"UNIVERSAL-SIX" AC-DC-BATTERY FOUR TUBE RECEIVER

IMAGINE! A compact, self contained, sensitive receiver with real SIX TUBE performance that will operate on any AC or DC house line. Simply plug in a cable and—**LISTEN!**—a completely battery operated set that you can use in your car, boat, or any other place! The same full toned loud speaker volume—the same thrilling foreign reception—the same ease of operation! No changes in wiring. Really TWO receivers for less than you would expect to pay for only one!

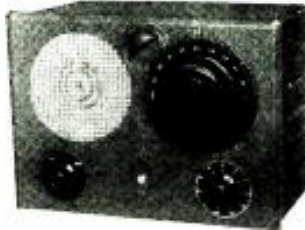

Look at this powerful tube line-up: Screen Grid pentode RF stage—electron coupled regenerative detector—THREE STAGE high quality audio amplification with power pentode output—heater type rectifier and humless power supply. **FULL SIX TUBE POWER** from two dual "Twin" 6F7 tubes and heavy duty 3B and 1-V tubes!

And these features: Full bandsread 9 1/2 to 625 meters—self contained, good quality loud speaker—New Transmitter type cabinet with dual speed friction drive—Provision for headphones—Indirect panel illumination—Velvet smooth control of regeneration—operates entirely from any AC or DC house socket OR ON BATTERIES (storage battery, or four dry cells, and three small B batteries) Low current drain means long, economical life of tubes and batteries.

This receiver is easy to build—easy to operate—and it certainly pulls 'em in! Order your Universal Six now! You will be amazed at the full loud speaker volume of distant stations! Every set is fully guaranteed. Buy with safety!

ACE UNIVERSAL-SIX **\$1275**
receiver with four tubes, cabinet, all coils, and built-in speaker. COMPLETE, nothing else to buy. Not wired.

Laboratory wired and tested, complete, ready to plug in. **\$14.50**

NOTE: If tubes, speaker, Broadcast Band coils, and cabinet are not desired at present you may deduct from the above prices **\$550**

• Literature on Request •

ACE RADIO LABORATORIES
Dept. C-11, 70 Barclay St., New York City

Please mention SHORT WAVE CRAFT when writing advertisers

New Apparatus for the "Ham"

(Continued from page 406)

that the manufacturers claim you can actually stand on it without destroying its shape. As for its efficiency, it is also claimed that this inductance shows no sign of distress when employed with an amplifier of over 1 kw. input.

ULTRA HIGH FREQUENCY CONDENSER, H70

With the increasing developments in ultra high frequency transmission and reception, there is a constant need for a new design in the various components used in the circuits. In keeping with this thought, Cardwell has recently announced a new tuning condenser designed for amateur transmitting apparatus and ultra high frequency diathermy machines.

This condenser is of the split stator variety having a capacity of 35 mmf. per section and an air gap of .084 in. Among its outstanding features are: no closed metallic loops; minimum surface leakage losses; extremely low minimum capacity; excellent insulation provided by Mycalex and Isolantite. The plates are extremely heavy, buffed and polished with rounded edges in order to further reduce losses. This condenser is excellently suited to ultra high frequency amateur apparatus including the 5 and 10-meter band and diathermy apparatus now prominently used in the treatments of various ailments.

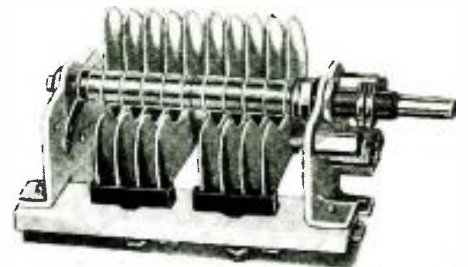

Ultra high frequency tuning condenser for amateur transmitters and diathermy apparatus, H 70.

ANNOUNCEMENT!!!!

● In an endeavor to incorporate a shade of the more humorous side of radio in *Short Wave Craft*, the Editors have decided to publish "squibs" submitted by the readers. These will be called "C.Q.'s," and must be authentic in origin; nothing fictional will be accepted. What we desire are oddities, humorous or otherwise and *Hot News* items of special interest to readers. They should be kept down to 15 or 20 words or less, and they must be original, i.e., experienced by the sender rather than copied from some other publication. The following will be the form of publication, and will more definitely illustrate the type of material we are looking for:

CQ

W2XXX raised three "Hams" with his auto horn riding through Squeduncus, much to the discomfort of other motorists and pedestrians.

CQ

Everytime W9?XX refers to the bottles in his transmitter, the Jr. Op. gets hungry!

O.K. fellows, let us have your oddities, and in return for each published we will award a year's subscription to *Short Wave Craft*. This is NOT a contest, but should two persons submit the same item, the one arriving first will be published and awarded the subscription. No manuscripts will be returned and absolutely nothing of a slanderous nature will be accepted; also, no practical joking will be tolerated.

Address all entries to: C.Q. Editor, care *Short Wave Craft Magazine*, 99 Hudson St., New York City.



HAYNES R-S-R

5 TUBE RECEIVER

2 1/2 to 555 METERS

THE IDEAL EXPERIMENTER'S SET

The Radio Editors See Them All! They Know!

The New York Sun:—"Circuits worthy of space are not numerous this season, but the R-S-R is an exception. The receiver functioned so smoothly that it was obvious its many features would appeal to the home experimenter."

Radio News:—"A Real Go-Getter . . . It considerably exceeded expectations. Short-wave stations were tuned in, all on the loud speaker, from Spain, Italy, England, France, Germany, Columbia, Cuba."

Short Wave News & Technical Review:—"Excellent long distance reception can be accomplished with it on all of the short wave bands . . . It is a whole lot of receiver for very little money."

REGENERATION PLUS SUPER-REGENERATION

Hundreds of R-S-R owners, scattered over the whole world, are testifying to the splendid consistent performance of this remarkable receiver.

5 BANDS selector switch covers from 555 meters down to 16 meters. No plug-in coils used over this entire range. High frequency range on down to 2 1/2 meters uses efficient, self supporting interchangeable coils with separate low C tuning condenser.

EXCLUSIVE DOUBLE REGENERATION control is one of the many refinements that has helped to make the R-S-R the outstanding DX regenerative receiver.

Complete R-S-R Receiver; ready to plug in to 110 volt line and operate, wired, tested, with 5 tubes, speaker and cabinet. **\$24.65**

Complete kit; unwired, including dynamic speaker, power supply and wired switch coil assembly (Less cabinet and tubes only) **\$14.95**

R-S-R JR.

3-TUBE COMMUNICATION RECEIVER 5 to 555 METERS

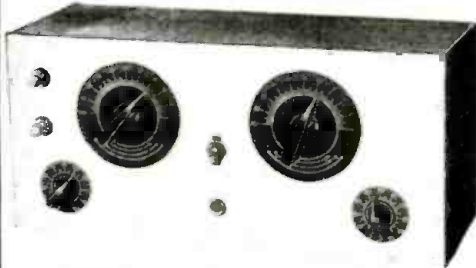

A NEW development of the Famous Haynes R-S-R at a remarkable low price for this class of receiver. A regenerative receiver with amazing selectivity. It actually will snap in and out the local broadcasting stations. Super-regeneration or straight regeneration as desired. Perfect smooth, silent regeneration control for phone, C.W. or broadcast reception—foreign or local. Uses 2—76 Super Triode tubes in electron coupled circuit and 80 rectifier.

FEATURES

- ★ Separate tank and band spread condensers.
- ★ Super-regeneration up to 25 meters if desired.
- ★ High voltage A.C. transformer power supply built-in.
- ★ Straight antenna or doublet connection with front panel variable antenna coupling.
- ★ Standby switch for communication work.
- ★ All coils are included, giving full coverage from 15 to 555 meters; also 5 and 10 meter bands.

COMPLETE KIT including all coils, drilled panel, chassis, power supply, etc., less tubes, cabinet and wiring **\$7.60**
 Crystallized Metal Cabinet.....\$1.00
 Kit of three matched tubes.....\$1.25
 Assembled, wired and tested.....\$2.35

A 3-TUBE POWER TRANSCIVER That Tops Them All!

Here is the latest model of the well-known RACO 5 meter power transceiver which has made such a remarkable record for long distance, high quality transmission. Uses two 42's and an 80 with 20 watts input to plates. Operates direct from 110 volt A.C. line. Separate regeneration and volume controls on reception; modulation control on transmission. Gives powerful speaker reception, or automatic ear-phone jack cuts out speaker. This job is in a class by itself among transceivers and is becoming too well known to require additional praise by us.

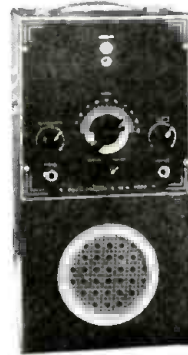

Complete kit, less speaker, tubes and cabinet, unwired.....\$11.50
 Cabinet and speaker.....2.75
 Wiring.....3.50
 3 tubes.....1.60

3-TUBE PORTABLE TRANSCIVER

Completely self-contained unit coupled 5 meter transceiver using two 19 tubes and one 30. An unusually powerful, long range battery transceiver possessing excellent stability and good modulation.



Push-pull D.C. self-excited with two stage push-pull class B audio in both sending and receiving positions giving true 5 tube performance. Batteries used: 3-45 V.R. and 2 No. 6 dry cells.

Complete kit, less cabinet, tubes, unwired.....\$10.95
 Assembled, wired.....\$3.00
 Cabinet.....\$1.50
 3 matched tubes.....\$1.65

RH-6 POWER DUPLEX

TRANSMITTER-RECEIVER For the High Frequency Bands

THIS RIG IS RIGHT!

You won't want to change a thing on it.

- ★ 6E6 (or RK-34) oscillator in unusually stable and efficient T. P.T.G. circuit.
- ★ 6L6 fixed bias, beam power modulation.
- ★ A really P.B. receiver, worth the price of the whole job, using the new 6J5G super-regen. detector (still gives smooth super-regeneration over whole condenser with only shorting bar as plug-in coil; a stage of R.F. which does work and two stage audio with 6L6 output to heavy duty dynamic speaker.

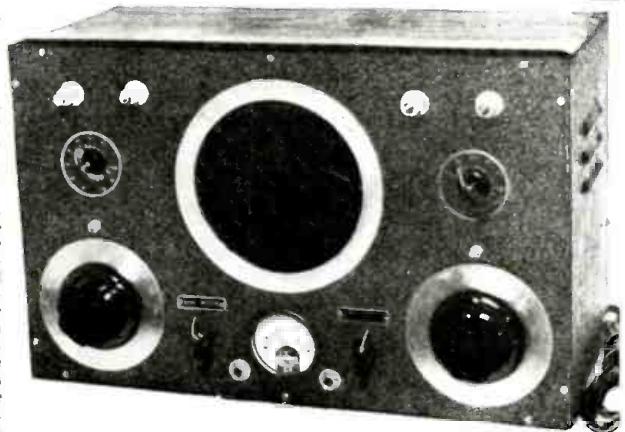

- ★ 150 mil. plate supply with double filter, in same cabinet.
- ★ 150 mil. meter switches to either oscillator or modulator.
- ★ 20 watt input with approx. 10 watt output (more with RK-34).
- ★ Coils supplied for 2 1/2 to 10 meters on receiver—5 meters on transmitter (may be shifted to 2 1/2 if desired).

RH-6 Power Duplex complete in hinged top cabinet 18"x10"x8" (Less tubes only) **\$35.75**
 Kit of six specially picked Sylvania tubes: 1-6L6, 1-6E6, 2-6J5G, 1-6D6, 1-5Z3 **\$5.10**

RADIO CONSTRUCTORS LABORATORIES

Dept. SW 11
 136 LIBERTY ST., NEW YORK, N. Y.



Export Dept.
 105 HUDSON ST., NEW YORK, N. Y.

Please mention SHORT WAVE CRAFT when writing advertisers









Build up your own library!

There is no substitute for KNOWLEDGE—it is the FOUNDATION of all SUCCESSFUL men. The money spent for standard technical books will repay your investment several times over in a comparatively short time.

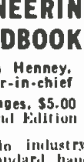
When in doubt on any VITAL subject, it is gratifying to find WHAT YOU ARE LOOKING FOR WHEN YOU NEED THE INFORMATION.

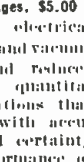
Select books from the list below and buy at least ONE BOOK A MONTH. In a very short time you will have a library of your own and the books will be CONSTANTLY available for REFERENCE OR STUDY.

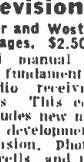
Books sent for 10 days' examination on approval. Send coupon below.

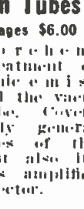
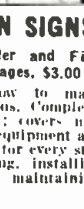
<p>PRACTICAL RADIO COMMUNICATION Principles, Systems, Equipment, Operation By Nilson and Hornung 754 pages \$5.00</p>  <p>Complete self-study text for men who want jobs in broadcasting, police, aeronautical or other radio stations.</p>	<p>RADIO OPERATING QUESTIONS AND ANSWERS By Nilson and Hornung 389 Pages 96 illustrations, \$2.50</p>  <p>Gives 600 questions typical of all classes of radio operator license examinations with answers. Covers broadcast, marine, aeronautical, police, and amateur radio-operating.</p>	<p>RADIO ENGINEERING HANDBOOK Keith Henney, Editor-in-chief 583 pages, \$5.00 Second Edition</p>  <p>The radio industry's own "standard handbook." Full, explicit, technical and practical data on all branches of radio engineering, presented by a staff of experts.</p>	<p>ELECTRON TUBES IN INDUSTRY By Keith Henney 490 pages, \$5.00</p>  <p>Practical electronics; how the electron tube works, how it is used in measurement and control of manufacturing processes to make them simpler, safer, and cheaper.</p>
<p>RADIO RECEIVING AND TELEVISION TUBES By Moyer and Westrel 635 pages, \$4.00</p>  <p>Covers principles, theories, and fundamental actions in vacuum and gaseous tubes. Includes applications for distant control of industrial processes and precision measurements.</p>	<p>Terman—RADIO ENGINEERING 750 pages, \$5.00</p>  <p>Analyzes electrical circuits and vacuum tubes and reduces them to quantitative relations that predict with accuracy and certainty the performance of radio circuits and radio apparatus.</p>	<p>RADIO CONSTRUCTION AND REPAIRING By Moyer and Westrel 444 pages, \$2.50</p>  <p>Clear, simple treatment of construction, installation, testing, and repair of radio receiving sets, including television and short-wave sets.</p>	<p>PRACTICAL RADIO—Including Television By Moyer and Westrel 410 pages, \$2.50</p>  <p>Practical manual on radio fundamentals and radio receiving apparatus. This edition includes new material on developments in television, photoelectric cells and neon glow tubes, new types of receiving sets, etc.</p>
<p>AMERICAN ELECTRICIANS' HANDBOOK By Terrell Croft \$4.00</p>  <p>1018 pages of direct helps showing you how to handle every type of practical electrical job; motors and generators and their troubles, indoor and outdoor wiring, transformers, etc.</p>	<p>High-Frequency Measurements By August Hund 491 pages, \$5.00</p>  <p>This is a reference book for research workers, students and teachers, giving a thorough discussion of high-frequency phenomena applied to measurements.</p>	<p>Chaffee's Theory of Thermionic Vacuum Tubes 652 pages \$6.00</p>  <p>Comprehensive treatment of thermionic emission and the vacuum tube. Covers not only general properties of the tube but also its use as amplifier and detector.</p>	<p>NEON SIGNS By Miller and Fink 288 pages, \$3.00</p>  <p>Tells how to make neon signs. Complete, practical covers materials, equipment and methods for every step in making, installing and maintaining signs.</p>

Short Waves at the Olympic Games

(Continued from page 392)

stalled around the arena the personnel in charge found it very valuable to have a "foot-loose" reporter on the job, and this short-wave "knapsack" transmitter filled the job nicely.

Giant Television Camera Used at Olympics

(Continued from page 392)

Important step toward the solution of these problems has been made recently in Germany by designing a television receiver which not only reproduces large-size pictures, but also allows television reproduction in the movie theatre on a full-size screen.

The magic behind this new receiver, designed by the Telefunken Co. (The German RCA) is a cathode-ray tube of the so-called flat-bottom type, i.e., a cathode-ray tube in which the reproduction screen is flat, not convex.

This improvement, at first glance a seemingly unimportant one, is actually quite involved. It is not necessary to be a scientist to conceive that a picture projected upon a screen of convex shape must be distorted. But all cathode-ray tubes at present in use for television transmission have a screen of convex shape. One must wonder why nobody before the Germans thought of this simple improvement. The Germans actually did not invent a new design of cathode-ray tubes, but were the first who utilized a new glass of American origin. This glass has the faculty of withstanding very high pressures without breaking.

The reason why a glass of this quality brought about this important improvement in television performance is as follows. We all know from our school days the well known physical effect that containers with flat sides can not be evacuated as much as containers of globe form. This is caused by the outside pressure which causes the bottle to collapse if the shape is not convex.

The Germans applied not only the new American glass but also made the walls of the new non-collapsible television tube 0.4 inch (1 centimeter) thick. The bottom of the tube, or to be more exact the "reproducer screen" of the tube is ground absolutely flat with the precision of an optical lens. By increasing the plate voltage to about 20,000 volts the electrons released in the tube are driven against the fluorescent screen with a speed of about 12,000 miles per second, and an extremely bright image reproduction is obtained. To give a comparison of the brightness it should be mentioned that the television picture appearing on the screen is so bright as to hurt the eye if observed direct. By means of a projection lens the small picture is projected upon a large screen 2x3 feet in size, and thus a great many observers can see the television transmission as clearly as a movie in the theater.

The clearness of the picture is due to the new transmission system operating with 360 lines. The color of the picture is black and white because of a new fluorescent material recently developed abroad. The remaining obstacle to the introduction of this receiver into the home is the price of the new apparatus, which is about \$2,000.00. This price does not prohibit its use by movie theaters who want to entertain their patrons between the main features with "television news reels," transmitted direct from the spot. A great many movie theaters in Berlin have given orders for the installation of such "television image reproducers." Television, so far as home reception is concerned, is still "around the corner" because of the high price asked for such a receiver, but as a commercial instrument for theater entertainment it seems to have arrived.

SEND THIS MCGRAW-HILL ON-APPROVAL COUPON

McGraw-Hill Book Co., Inc., 330 W. 42nd St., New York, N. Y.
Send me the books checked below, for 10 days' examination on approval. In 10 days I will pay for the books, plus five cents for postage, or return them postpaid. (We pay postage on orders accompanied by remittance.)

<input type="checkbox"/> Nilson and Hornung—Practical Radio Communication, \$5.00	<input type="checkbox"/> Moyer and Westrel—Radio Construction and Repairing, \$2.50
<input type="checkbox"/> Nilson and Hornung—Radio Operating Questions and Answers, \$2.50	<input type="checkbox"/> Moyer and Westrel—Practical Radio, \$2.50
<input type="checkbox"/> Henney—Radio Engineering Handbook, \$5.00	<input type="checkbox"/> Croft—American Electricians' Handbook, \$4.00
<input type="checkbox"/> Henney—Electron Tubes in Industry, \$5.00	<input type="checkbox"/> Hund—High-Frequency Measurements, \$5.00
<input type="checkbox"/> Moyer and Westrel—Radio Receiving and Television Tubes, \$4.00	<input type="checkbox"/> Chaffee—Theory of Thermionic Vacuum Tubes, \$6.00
<input type="checkbox"/> Terman—Radio Engineering, \$5.00	<input type="checkbox"/> Miller and Fink—Neon Signs, \$3.00

Name

Address Position

City and State Company

(Books sent on approval in U. S. and Canada only)

Please mention SHORT WAVE CRAFT when writing advertisers

Ultra 1 and 2 Tube Battery Transceivers

For the beginner in the field of ultra high frequencies we unhesitatingly recommend these extremely efficient 1 and 2 tube transceivers. Can be used as a 2 1/2, 5 and 10 meter receiver as well as transmitter when calling friends from afar. The one (1) tube unit uses a 19 type tube. The 2 tube unit uses one 19, plus the (new) 1F4, Class A modulator. Longer battery life is had with this combination. Greatest possible range of any small transceivers can now be had. Batteries required are 2-1 1/2 V. dry cells and 90 to 135 B battery.

PICTORIAL DIAGRAM FURNISHED WITH KIT

(2 TUBE MODEL)

Complete kit of parts including all coils, less tubes, cabinet, microphone and batteries..... **\$6.95**
 Wired and tested..... **\$2.00**
 Sylvania 19 and 1F4 matched tubes (2)..... **1.45**
 Cabinet less battery compartment..... **1.10**
 Cabinet with battery compartment..... **1.95**
 American S.B. Hand-mike..... **2.95**

(1 TUBE MODEL)

Complete kit of parts including all coils, less tubes, cabinet, microphone and batteries, unwired and tested..... **\$1.50**
 1 Sylvania 19 tube..... **.58**
 Cabinet less battery compartment..... **1.10**
 Cabinet with battery compartment..... **1.95**
 American S. B. Hand-mike..... **2.95**

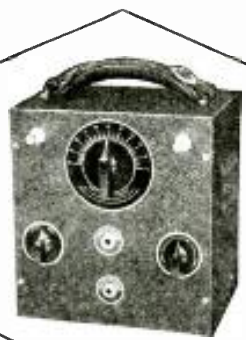

We specialize in all types of ultra high frequency equipment.

3-TUBE Ultra Converter-Receiver 1 1/2 to 10 Meters

This all purpose unit may be used as a converter or home broadcaster in conjunction with your big set or as an entirely separate receiver. Connects directly to Antenna post of any broadcast set. Entirely powered by its own built-in power supply. A.C. operation. A unique provision is made for home broadcasting with a single burning carbon mike. Tubes used 6J5G, detector, 6ASG, electronic mixer, 25Z6G rectifier.

Complete kit of parts, unwired, including all coils, less tubes & cab. **\$9.50**
 Kit of 3 Sylvania tubes 6J5G, 25Z6G, 6ASG..... **2.75**
 Black wrinkle finished cab..... **1.10**
 Wired & tested extra..... **2.50**

ULTRA 3-TUBE A. C. Transceiver 2 1/2 to 5 Meters

This new A.C. operated transceiver built and designed to take full advantage of the latest tubes which have been released affords power as a transmitter and sensitivity as a receiver never before available at anywhere near this price. Complete with built-in power supply. Tubes used, 6J5G detector-oscillator, 25A6G amplifier, Class A modulator 25Z6G; voltage doubler rectifier. Supplied complete with all coils including coil for 10 meter reception.

Complete kits of parts, including coils, unwired, less tubes, microphone, antenna, & cab. Kit of 3 Sylvania tubes 6J5G, 25A6G, 25Z6G..... **2.97**
 Black wrinkle finished cabinet..... **1.10**
 Wired & tested extra..... **2.50**
 American S.B. Hand-mike..... **2.95**
 Adjustable 8 ft. Antenna..... **1.60**

ULTRA 5 T ALL WAVE 5-TUBE Communications RECEIVER AC & DC 2 WATTS OUTPUT 1 1/2 to 600 Meters



- ★ New tubes 2-6K7, 1-6J5G, 1-25Z6, 1-25B6G
- ★ Electrical bandspread
- ★ Receives phone & C.W. signals
- ★ Built-in dynamic speaker

- ★ Built-in power supply
- ★ 9 bands
- ★ Dial illumination
- ★ Headphone jack

This new amateur communications receiver embodying a multitude of features including electrical bandspread, super-regeneration from 1 1/2 to 15 meters, 2 watt power output made possible by the new super output tube 25B6G, and many others too numerous to mention, is now available for the use of the discriminating amateur. 1 1/2 to 600 meters linear in efficiency is accomplished by the use of super-regeneration up to 15 meters and straight regeneration with 5 band switching to 600 meters. The newest type tubes are used as follows: 6K7-RF stage, 6K7-regenerative detector, 6J5G ultra high frequency detector, 25B6G super power output stage, 25Z6G rectifier. Built-in dynamic speaker. Self contained A.C.-D.C. power supply, large illuminated airplane dial, automatic phone-jack.

Complete kit of parts less tubes and cabinet unwired..... **\$3.00**
 Wired and tested, extra..... **\$4.50**
 Sylvania kit of 5 tubes..... **4.50**
 Black wrinkle finished cabinet..... **2.50**
 Set complete with 5 tubes and cabinet, wired, ready to operate..... **23.10**

"ULTRA DUPLEX"

5-TUBE BATTERY PORTABLE 2 1/2 to 5 Meters (56 to 120 MC)

- ★ 1C6-1F4-19-1B4-1E7G
- ★ Positively duplex
- ★ Built-in loudspeaker
- ★ New type detector circuit
- ★ 100% Class A modulation
- ★ Extremely low current drain
- ★ Absolutely non-radiating
- ★ Increased effective sensitivity

Embodying all the latest innovations of the ultra high frequency field, this really compact and separate receiver and transmitter successfully fulfills the innermost desire of the Amateur for trouble free duplex operation. The receiver consists of a 1C6 detector operating on an entirely new and heretofore unharnessed principle, and a 1F4 amplifier. The new 1E7G Class A modulator together with a 1B4 speech amplifier and 19 oscillator comprise the transmitter. Separate antennas are used to insure peak performance of both units at any frequency settings.

Supplied complete with all coils, including coil for 10 meter reception.

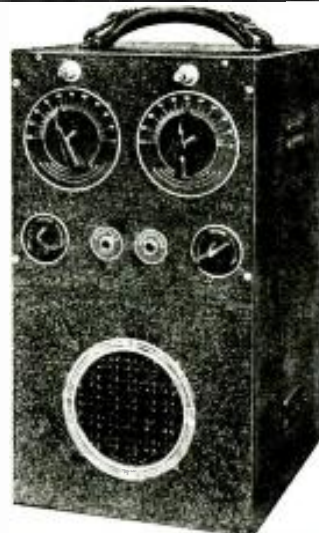

Complete with built-in speaker, and cabinet with battery compartment, wired and tested, less tubes, batteries, microphone and antenna. **\$19.95**
 Set of 5 Sylvania tubes..... **\$4.62**
 American S.B. Hand-mike..... **\$2.95**
 Adjustable 8 ft. Antenna..... **\$1.60**

The Ultra A.C. Duplex will soon be released featuring 6L6 Beam tubes in an entirely different circuit. Write in for advance information.

WRITE IN FOR FREE DESCRIPTIVE ULTRA HIGH FREQUENCY LITERATURE

ULTRA HIGH FREQUENCY PRODUCTS CO.

140 LIBERTY ST. N. Y. C., N. Y.

A New Sargent Receiver for the Ham and Fan

(Continued from page 405)

all coils that could introduce losses into the wave-band that is in use. As a result there is no apparent loss due to the presence of the other coils, and the addition of the long-wave tuning ranges makes no change in efficiency of short-wave reception. Efficiency of long-wave reception is on a par with that of short waves. Particular attention has been paid to reception in the vicinity of 600 and 2200 meters, and the wavebands have been so arranged as to give a high L/C tuning ratio at these important wavelengths. This set for 3 volt Air Cell and 2 volt wet cell operation, tunes down only to 15 meters. Because of complications unavoidable in filament type tubes, operation of these models on 9.5 meters is not satisfactory.

The Circuit—The circuit employs one stage of tuned radio frequency amplification, regenerative detector and two stages of audio. A phone jack is placed at the output of the first audio stage, and the speaker is cut out when the phone plug is inserted. A.C. models use an 80 rectifier and have a total of 5 tubes—the D.C. and battery models have 4.

Tubes—The tube line-up is as follows: A.C. models use a 6D6 in the R.F. stage, 6C6 detector, 76 first audio, 42 second audio and 80 rectifier. Model 11 for 110 and 220 volts D.C. uses the same line-up as above for the R.F. stage, detector and first audio and uses a 43 output tube. For 6 volt battery model the line-up is the same except that a 41 output tube is used. The 3 volt and 2 volt models use a 34 R.F. stage, 32 detector, 30 first audio and 1F4 output tube.

Power Supply—A. C. models have built-in power supply, and these receivers are thus completely self-contained units. The hum level is so extremely low that it may properly be termed "humless."

Band-Spread—Mechanical bandspread is used. All amateur bands are spread on this receiver. See illustration of the band-spread dial. This band-spread has been developed to a point where it is surprisingly accurate, easy to adjust and free from backlash.

Break-in Switch—When the toggle switch at the right-hand end of the receiver is in the down position the cathode of the R.F. tube is biased to the cut-off point. This protects the tubes in the receiver from overloading during transmission. This system has an advantage over the usual "B" break, in that it is instantaneous in operation. Also there is enough leakage

signal from the transmitter to operate the detector tube and this permits of "monitoring" the transmission. If desired, wires from a relay can be attached to the switch terminals for break-in telegraph or phone transmission.

Other Controls—An R.F. stage trimmer is mounted on the panel. Thus the operator can be certain at all times that both sets of coils are in absolute resonance. An R.F. Gain Control gives the receiver sufficient flexibility so that it can be used on any size antenna and enables it to function properly under differing interference conditions. The headphone jack is mounted on the left hand end of the receiver.

Cabinet Construction—The Model 11 uses the same "tray-type" panel and chassis construction that was introduced with Sargent Model 12. Remove 6 thumb screws and the entire panel and chassis can be drawn out the front of the cabinet, available immediately for tube changing or inspection. Power wires need not be disturbed while doing this, and the cabinet may be permanently anchored in place if desired without in any way interfering with servicing of the receiver. Cabinet and panel are finished in black crackle, a handsome, permanent finish and etched name plates are provided for all controls.

This article has been prepared from data supplied by courtesy of E. M. Sargent Co.

Please mention SHORT WAVE CRAFT when writing advertisers

**I Will Show You How
ONLY 17 CENTS A DAY**

**ACTUALLY SETS YOU
UP IN BUSINESS ...**

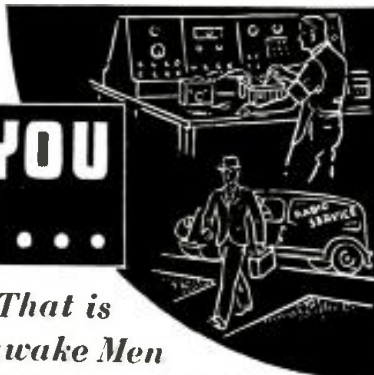

*.....Start NOW in an Industry That is
Providing Fortunes for Wide-awake Men*

The Sprayberry Method of training men for good paying jobs in Radio does more than teach you simple theory. It teaches you proven Radio business methods—and backs up every step of your Training with REAL PROFESSIONAL RADIO EQUIPMENT.

No matter what kind of radio training you take, you cannot go into business without equipment. Such things are just as necessary as are dental tools to the dentist or instruments to a musician.

Sprayberry Training brings this necessary equipment to you almost at the start!—teaches you how to use it under actual working conditions. Upon completion of the Course you have COMPLETE business and technical training PLUS the needed equipment to enter business at once for full or spare time profits—or to start off on a career in any one of Radio's specialized fields, such as Public Address, Commercial Radio, Broadcasting, etc.

ACT TODAY—Radio, today, shows a profit and its future is bright. The industry is going ahead by leaps and bounds. And Television is on its way! Today is the time to get started—and Sprayberry Training will start you right. Investigate today. Make me prove to you that 17 cents a day will start you in the Radio business!

LEARN QUICKLY—PREVIOUS EXPERIENCE NOT REQUIRED

You'll find Sprayberry Training complete—modern practical—easy to understand. You learn quickly at home in spare time. Students can often make extra money on ordinary service work before completing their training.

CASH IN ON REAL RADIO TRAINING THAT PROVIDES YOU WITH

PROFESSIONAL RADIO EQUIPMENT

The Sprayberry Academy of Radio is the only school furnishing this professional Radio Equipment with its TRAINING—combines the advantages of both the residence and home study methods of Training.



**SPRAYBERRY ACADEMY OF RADIO,
F. L. Sprayberry, President
2544 University Place, N. W., Washington, D. C.**

Without obligation on my part, please send your book, "Your Future in Radio" and other details of the famous Sprayberry Method of Training.

NAME

ADDRESS

FASTEN THIS COUPON ON A PENNY POSTCARD AND MAIL TODAY

**SCOUT THE AIR WAVES WITH H. G. CISIN'S
WONDERFUL NEW 1937 METAL TUBE JUNIOR**

SPACE EXPLORER - 6 —B— MODEL

All-Electric 4-Tube Receiver

**COMMUNICATION TYPE—PROFESSIONAL PERFORMANCE
CERTIFIED FOREIGN RECEPTION**

SIX bands, range 11 to 500 meters continuous coverage—also long wave to 1500 meters if desired. Self-contained power supply and full-sized quality speaker. Phone Jack at front. Antenna Control. Dual Retention control. Metal 6J7 pentode regen. det.; metal 6C5 screen grid 1st audio; newest metal tube K-105-A Ballast; 38 power output pentode. Full-vision triple calibrated dial. Precision Instrument type Bar Knob. Operates a.c. (any frequency) or d.c. (Cisin Circuit Patent pend. No. 302,586). Easily built—no dual purpose tubes to complicate wiring. Wood cabinet easily made saves cost of metal and gives superior tone quality. Full directions with kit.

COMPLETE KIT—High quality Find-All parts including Loud Speaker, diagram, instructions unwired, less tubes, coils, cabinets. \$6.95

Four Find-All Short Wave Coils—\$1.65. Two Broadcast Coils—85c. Special Long Wave Coil with L. W. Unit—95c. Set of Four Matched Tubes inc. K-105-A—\$2.95. Two ornamental Rings for Panel Front 25c each.

**H. G. CISIN, Chief Engineer ALLIED ENGINEERING INSTITUTE
Dept. S-30 98 Park Place New York, N. Y.**

Philco Shows Television

(Continued from page 391)

Picture quality equal to that of "home movies" was, and still is, their goal. Such a requirement forced engineers to be careful of small defects, distortions and the like, whether due to the camera tube, the picture tube or the system. This led to larger, brighter cathode ray tubes, and camera tubes (for pick-up of image) of improved sensitivity and detail. Cathode ray projection tubes were built to explore the paths leading to larger pictures. One conclusion drawn from these experiments was the desirability of using more than 240 lines.

The next progressive step appeared to be a 345-line picture. Some reasoned that a good 240-line system would give better pictorial results than a fair 345-line system. However, it was decided to try 345 lines. In due course amplifiers were improved, special tubes designed to meet the new requirements, and new scanning equipment built. Once again defects and distortions had to be eliminated one by one.

Again a satisfactory image was obtained first by wire. The next step was to reproduce this at a distance by radio. Philco's experimental television transmitter W3XE, was rebuilt, and with power increased to 1.5 kw. images again were flashed over the roof-tops of North Philadelphia. This was the beginning of the fourth stage in the development.

Transmission of Images was a Problem

The job of transmitting over the city of Philadelphia and its suburbs television signals of sufficient strength to give usable "high-definition" pictures at a distance of at least 7 miles from the plant, was not an easy one on the ultra-high frequencies used for television. The newest ideas in U.H.F. transmitters, antennas and transmission lines were tested. Considerably more power was required at the transmitter to cover the desired distance than sound broadcast experience would indicate.

New Method of Modulation

One of the most difficult problems to be solved was the modulation of the transmitter by the very high video frequencies (generated by scanning) necessary for high-definition television pictures. It is a relatively easy matter in a sound transmitter to modulate from 30 to 10,000 cycles, but when the upper limit of the modulation band is pushed to 2.4 megacycles (2,400,000 cycles per second! The problem of constructing amplifiers and modulators appears at first insurmountable. The solution was the invention of a new and unique type of modulation.

Concurrently ultra-high frequency radio receivers (42-86 mc.) were being developed to faithfully reproduce these high modulating frequencies necessary for clear, high-definition pictures. Receivers for the accompanying sound were also developed so that the apparatus necessary to receive a television program (sound and picture) could be placed in an ordinary console.

Field Tests Begin

With all of the units of a complete system developed and operating satisfactorily, field tests were ushered in on December 23, 1935, by a one-hour program reproduced at a distance of 7 miles from the transmitter. This demonstration was witnessed by a number of Philco executives. It showed that the system lacked many desirable features. Nevertheless, the results were sufficiently promising to once again concentrate on the weaker links of the system, to remove the cause of weakness and to improve the picture. Subsequent demonstrations made at frequent intervals (to Philco executives and their guests) showed rather slow but steady progress up to that point where scheduled programs were broadcast nightly by Philco, covering Philadelphia, on 51 mc. (picture) and 54.25 mc. (sound). These were started June 18, 1936.

Please mention SHORT WAVE CRAFT when writing advertisers

This date marks the beginning of the fourth stage of the development—engineering field tests. This is the stage in which we are at present. Experimental console type of receivers are in the homes of various company engineers in Philadelphia, who receive and report on the programs. These reports, together with suggestions concerning receiver improvements, etc., form data helpful in the design of future models.

The Philco system will conform with the new suggested standard of 440-450 lines. This matter of having one television standard for the U.S.A. is very important. It will be appreciated by every future television user.

At the transmitting station the logical starting point is the studio, where the television signal is generated. The studio is located in our main laboratories C and Tioga St. A camera employing a Philco camera tube generates by electrical scanning, voltages corresponding to the light and shade of the television picture which is focused by a lens on the signal plate of the tube. This signal is amplified in cascaded stages (about 10,000 times) in the control room until it has sufficient amplitude to modulate the U.H.F. transmitter. Mixed with this television signal, in the proper proportions, are synchronizing and blanking impulses. These control, at the various television receivers in the field, the movement of the electron beam in the picture tubes and place around two sides of the picture a black border. To pick up the sound accompanying the picture the studio is equipped with microphones and associated equipment, which permits transmission of high fidelity sound from their U. H.F. sound transmitter operating on a frequency spaced 3.25 mc. above the television carrier wave.

Motion picture film, when passed through a specially-built projector, is transmitted by flashing pictures intermittently into the so-called "electric eye," or camera tube. This projector is designed so that the film (and its "sound track") is moved at a speed of 24 frames per second and 30 frames per second are scanned so as to secure 60 interlaced pictures per second.

For outdoor television scenes the camera is placed on a motion picture tripod and motion picture technique is used in its operation.

The experimental model of cabinet used in the demonstration comprises a sound and television receiver, tuning over the frequency range of 42-86 mc. For flexibility these receivers are separately tuned, although it is easy to secure *single knob* control. The number of control knobs is only slightly more than on the usual sound receivers. These are not difficult to operate. Field tests have shown that inexperienced persons can adjust the knobs to secure satisfactory pictures. The deflecting chassis is the name given the unit which incorporates the synchronizing and deflecting equipment. The power-supply units are placed at the bottom of the cabinet. The total number of tubes used is 36.

The large majority of our readers will have two television questions they would like to have answered—"When" and "How Much?" Mr. Larry E. Gubb, President, Philco Radio and Television Corporation, answered the former question the first of this year in the *New York Times* by saying—"commercial television will not come during 1936." This was a definite statement. Just when in the future *commercial television* will arrive, no one can say. It may be in one year or it may be in five years.

It is too soon to answer the question of "How Much?" Estimates or rather guesses have been made that television receivers will cost, upon their introduction, \$500.00.

"You are being shown the results of Philco research more to establish a milestone this eleventh day of August, 1936, to which, in the future, we can refer in order to judge our rate of progress. Important new improvements are to be incorporated. We hope again to have the pleasure of demonstrating, sometime in the near future, our next television milestone," said a Philco spokesman.

The New Doerle 6-Tube BANDSPREAD RECEIVER Marvelous Sensitivity and Selectivity Only Found in the Higher Priced Models

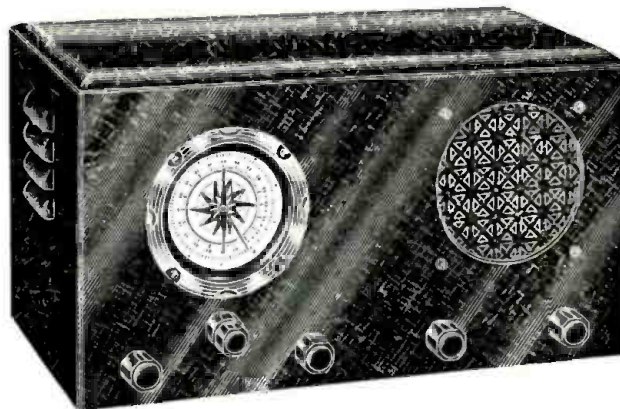

- ★ Continuous bandspread tuning from 9½ to 625 meters.
- ★ An ideal DX receiver for the long distance SW fan or communications receiver for the transmitting amateur.
- ★ Beautiful large, illuminated, dual pointer, multi-colored, airplane type dial of great beauty.
- ★ Operates from either single wire type aerial or noise-free doublet.
- ★ Volume control—stage aligning trimmer—and tone controls.
- ★ Unusually smooth acting regeneration control.
- ★ Headphone jack with speaker cut-off switch.
- ★ Highly efficient, low loss ribbed plug-in coils, are a large factor in the amazing sensitivity and selectivity of this receiver. Coils are of the large 3 winding variety and are color coded for easy identification.

The famous Doerle line of receivers are now equipped with the new Octal sockets in which glass and metal tubes are interchangeable. For the first time this quality receiver is available in KIT form for the short wave experimenter who prefers to "build his own."

Uses 6 of the latest hi-gain tubes (6K7G, 6K7G, 6C5G, 6C5G, 6F6G and 5Y3) in a highly efficient and selective circuit, using two tuned stages—electron coupled regenerative detector—POWERFUL 3 stage resistance capacity coupled audio frequency amplifier with power pentode output stage—full wave high voltage rectifier and self contained hum-free power supply. Built-in High Fidelity dynamic speaker capable of handling the entire 3 watts of audio frequency power output of the receiver.

Continuum bandspread over the entire range of 9½ to 625 meters is obtainable due to the use of a special type, multi-colored, airplane dial having 125 to 1 ratio and two pointers. Two knobs are provided and make possible either fast or slow motion tuning. ALL of the AMATEUR and FOREIGN SW BANDS are spread over a generous portion of the tuning dial, thereby simplifying tuning so that even a beginner can operate it to the utmost satisfaction. Entirely free from all traces of backlash.

The entire unit is contained in a large, black crackle finished metal chassis and cabinet of extreme beauty. All controls are mounted on the front panel and all parts are readily accessible. No adjustments whatever are necessary. Nothing to get out of order. Simply plug into your electric light socket and enjoy an evening of short wave thrills and entertainment such as you have never before experienced.

Mechanical specifications: Dimensions are 17½"x8"x8¾". Net weight 23 lbs. Shipping weight 33 lbs. Designed to operate entirely from 100-130 volts, 50 to 60 cycles AC house current. Shipment made same day as order is received. Complete satisfaction guaranteed.

DOERLE 6-tube AC BANDSPREAD RECEIVER, completely wired and tested, with set of 6 matched Arcturus tubes, 8 coils for 9½ to 200 meters, cabinet, instructions, and READY TO OPERATE. (Specify whether metal or glass tubes desired.)

DOERLE 6-tube AC SW KIT, containing all necessary parts, including 8 low loss ribbed coils for 9½ to 200 meters, full size hi-fidelity dynamic speaker, beautiful cabinet, and 4 page instruction booklet (less tubes, Broadcast coils, and unwired) **\$17.96**

6 Arcturus matched tubes: \$3.12
Broadcast hand coils (2) 1.45

LIST PRICE \$34.95
Discount to Hams, Fans & Experimenters 20%
YOUR NET COST

\$27.96

less 2 Broadcast hand coils, extending the range up to 625 meters, extra \$1.45.

INVEST in a GENUINE DOERLE 2-TUBE BATTERY RECEIVER

15 to 200 Meters

\$7.25
KIT
Less Tubes, Cabinet, and Batteries

One of the most popular members of the Doerle Set family. Employs but two tubes, yet gives the performance of a set having three tubes. Uses a type 30 as regenerative detector and a type 19 twin triode (actually 2 tubes in one) as two stages of resistance-coupled audio. The world-famous reputation of the entire Doerle line, is behind this remarkable set. Requires two No. 6 dry cells and two 15 volt "B" batteries for operation. All parts and workmanship fully guaranteed. Employs a set of four 5-prong ribbed plug-in coils. These coils are interchangeable with the new 5-prong bandspread coils. Ship. wt. 10 lbs. List Price \$14.75.
Doerle 2-tube Battery Receiver Kit, not wired, but including Coils, less Tubes, Batteries and cabinet. YOUR PRICE **\$7.25**
Set of 2 Matched Tubes \$0.98
Metal Cabinet for above 1.25
Set of 4 Bandspread Coils 2.95



We will wire and test any of these kits at an additional charge of \$1.50

FREE CATALOG OF DOERLE RECEIVERS. Send stamp to cover mailing costs.

GUY STOKELY RADIO CORPORATION, 126 Liberty St., Dept. S-11, New York City
SOLE MANUFACTURERS AND DISTRIBUTORS OF DOERLE SETS

Please mention SHORT WAVE CRAFT when writing advertisers

NOW! ALL Standard Receivers and MARINE Transmitters available on the new MARINE RADIO BUDGET PLAN

At standard Amateur net prices, plus small carrying charge. Write for full details.

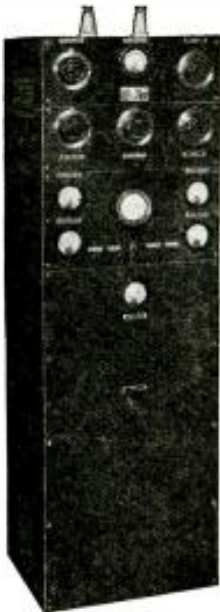

MARINE TRANSMITTERS
 22BP 20 watts phone and CW
 35B 40 watts phone and CW
 18A 40 watts phone—160 watts CW
 83B 50 watts phone and CW
 60F 60 watts phone—200 watts CW
 140H 100 watts phone—100 watts CW
 140C 200 watts phone and CW
 270H 350 watts phone and CW
 750H 1000 watts phone and CW
 Also a series of special purpose transmitters.

PROMPT DELIVERY ASSURED ON FOLLOWING RECEIVERS
HALLICRAFTERS—Sky-Buddy
 Ultra-Skyrider
 New Super-Skyrider
 Skyrider Commercial
 Sky-Chief
NATIONAL—HRO
 HRO, Jr.
 NC 100, etc.
PATTERSON—PR-16
 RME 69
SARGENT—Models 10, 11, 12, 20

In step with progress in the radio field Marine engineers have, from time to time, designed their transmitters to incorporate the latest developments of the art. Close adherence to the "MARINE" standard of "Quality First" is a characteristic of all Marine equipment.

All Marine Transmitters are equipped with "Over-modulation Indicators" or Cathode Ray Oscilloscopes. Automatic relays and other safety devices afford ample protection to both the operator and the equipment.

We develop and construct special equipment for electronic and communication purposes.

Your inquiry will receive our prompt and careful consideration.

Illustrated descriptive catalogs will gladly be furnished upon request.

MARINE RADIO CORPORATION
 62 Lispenard Street
 New York City



Television and Short Waves To-morrow!

(Continued from page 393)

that television when it "breaks" tomorrow, will use mostly "film" image or studio and live actors? How about recording scenes and voice or music for programs which may have to be repeated several hours later for Western audiences?

A. It is possible that in the early days of American television film will be called upon to carry a good bit of the program schedule. This is likely to result from the need for sufficient diversification in the program content, bearing in mind the limited scope of the direct pickup during the early days.

It is my belief that America will follow the same general practice in television as it has in broadcasting, namely, to endeavor to present, insofar as possible, "live" talent as against recorded talent. A live talent program could be retelevised for a West Coast audience in the same manner that a network program is now rebroadcast at a later hour for the same purpose. This, of course, assumes that coast-to-coast facilities will eventually be available for television transmission.

Will Few Powerful Stations Replace Present 600?

Q. From your experience in directing the largest chain of broadcast stations in the world, do you think that tomorrow instead of having 600 odd broadcast stations in the U. S., for example,—that we may have a small number of real high-power stations? What individual power should a "net" of say 40 or 50 such stations have to cover the U. S.?

A. It is not likely that the total number of broadcasting stations in this country will be decreased, regardless of technical advancement in the art of broadcasting. This I believe to be true because cities and towns all over the country will continue to want to have broadcasting stations which they can "call their own" and which can, primarily, serve their local interests. However, the possible advent of both higher powered stations and high frequency stations may considerably change the American broadcasting structure in the next few years, as compared to the present.

Q. Do you believe the new Armstrong "frequency modulation" system will have any early practical application to broadcasting, bearing in mind the wide frequency band required for its adaption? And secondly, its power to reduce the effect of static?

A. Armstrong's frequency modulation system undoubtedly possesses many advantageous features, notably its ability to reduce interference as between signal and noise and as between two signals operating in the same band. However, the fact that the system requires a channel about twenty times as wide as the present amplitude modulation method, makes it questionable whether the system can be generally adopted for broadcasting, simply on the basis of the already over-crowded condition in the radio spectrum and the constantly increasing demand for facilities for new and additional services.

Recording Programs for "Repeats"

Q. Does CBS now, or expect to in the near future, record voice and music on a moving steel tape device, such as the Blatnerphone, used by the British Broadcasting System or the Lorenz machine used in Germany, for recording programs which are to be repeated several hours later? If not, what system is used by CBS, if any? (It is understood that at present several of our largest broadcast features are repeated in this country in full by the actors and singers for Western listeners.)

A. As a matter of policy, Columbia never transmits any recorded programs. The only exception to this rule is where "sound-effects" records are employed as incidental to the transmission of a dramatic type of program. Many of Columbia's programs are repeated in full by the entire cast, a few hours later, for Western listeners.

STANDARDIZED METAL EQUIPMENT

Enclosed Relay Racks
 Channel Relay Racks
 Sectional P. A. Racks

All purpose Metal

CABINETS

Single, double, triple units
 Steel Rack Panels
 Meter Panels
 Speaker Panels
 Aluminum Rack Panels
 Blank Steel Chassis
 Bases
 Loud Speaker Cabinets

Par-Metal Products Corp.
 35-25 41st St.,
 Long Island City, N.Y.



★PEAK PRE SELECTOR PRE AMPLIFIER

HEAR STATIONS YOU NEVER HEARD BEFORE

The PEAK Regenerative High-gain Pre-selector tremendously increases the sensitivity and selectivity of any receiver. Greatly decreases noise to signal ratio. Rejects image.

- Two tuned stages—9 to 200 meters
- Silver plated contact band change switch
- Self contained heater supply
- Automatic 11 c. changer switch
- Smooth control.

The P-11 is so easy to use: a moment and it is connected to any set. Every one is sold with an unqualified guarantee to markedly improve reception with any receiver—far beyond any similar unit sold! It will make a NEW receiver out of an old set.

HAMS! PEAK P-11 is highly recommended by Amateurs and Commercialists all over the world! Bring your weak, unreadable signals up to R-9! You can't work 'em if you don't hear 'em!

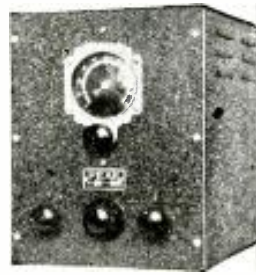

You just can't afford to be without the PEAK P-11!

PEAK P-11. Complete, less two 35 tubes. List price \$23.00. Net price..... **\$19.80**

At all leading Amateur Supply houses. Write for literature.

PEAK RADIO PRODUCTS

227 Greenwich St., C-11 New York City

RECEIVERS • TRANSMITTERS • KITS

Since 1925

"Harrison" has been the "buy-world" of discriminating Amateurs everywhere! Throughout the years an ever increasing number of Hams, beginners and old-timers alike, have come to consider Harrison as the one really dependable Amateur supply company. There must be a reason—and there is! In fact, there are several—

- ▶ Prompt, intelligent SERVICE that makes mail order buying a pleasure!
- ▶ Prices that actually mean more watts per dollar!
- ▶ Enormous stock enabling immediate shipment without substitution!
- ▶ Unconditional guarantee of complete satisfaction with every transaction!

SHORT WAVE FANS!!

Send for our Free Receiver Catalog
 (Time Payments Arranged)

AMATEURS!!

A card brings our latest FREE HAM BULLETIN.
 Send for it today!

TUBES • PARTS

HARRISON RADIO COMPANY 12 WEST BROADWAY NEW YORK Dept. C-11 N. Y.

Please mention SHORT WAVE CRAFT when writing advertisers

Q. Does CBS intend to use a greater number of "short-wave pickups" from Europe during the winter season? (Compared to last year).

A. The number of European programs rebroadcast by Columbia has shown a steady increase from year to year. There is every reason to believe that this trend will continue.

Q. Is CBS contemplating changing many of their stations to "high fidelity" transmission, and what frequency limit does your experience indicate will be the probable ones put into practice in the future in order to obtain high-quality reception?

A. All stations under Columbia management can be considered to be transmitting "high fidelity," as they are constantly kept abreast of the latest developments in the radio art. Several of the improvements in radio transmission have been initiated at Columbia stations and a good bit of the measuring equipment, now required by the FCC, in order to determine the operating characteristics of the transmitter, was developed in Columbia laboratories and first installed at Columbia stations.

Synchronizing 2 Stations on Same Frequency

Q. Do you at present, or in the near future, contemplate tying together several stations with an interlocking frequency? What has been your experience or results on the part of the listening public that may have come to your attention where a station located at a distance from New York may pick up another station on the same system, operated on the same wavelength by such a system of interlocking control? (In other words, the receiving station, when it tunes to the N. Y. wave, will frequently hear in the background, especially during announcements, the program or wave of the other station.)

A. There are two stations on the Columbia network which are synchronized on the same wavelength. These are stations WBBM in Chicago and KFAB in Lincoln, Nebraska. Our experience in this case has been entirely satisfactory and the net result may be said to be the augmenting of the signal from one station with the signal from the other. This occurs in the area between the two stations. Since both stations carry the same program when they are synchronized and since the program transmission is "elayed" to the first station until the program reaches the second station, it is transmitted from both stations without any time difference. By taking this precaution, no undesirable results occur.

Q. Are any of your short wave pickup programs from Europe or other parts of the world picked up by your own short wave receiving station, or are they picked up by the A. T. & T. Co's station and fed to the CBS System through the A. T. & T. Co. Long Lines Dept., 32 Sixth Avenue.

A. All of Columbia's trans-oceanic short wave programs are picked up by the commercial receiving facilities of either the A. T. & T. Co. or RCA Communications, Inc. This is also true of the National Broadcasting Company and the Mutual Broadcasting System, except in the latter case, I believe they occasionally use the short wave receiving facilities of the Canadian Radio Commission. By employing such facilities, we are not limited in the scope of our activities and can pick up programs from practically any place in the world, by employing receiving facilities on the West Coast or in Hawaii, with as great ease as we employ them in New Jersey or on Long Island.

New Commercial S-W Broadcaster
 H13C, La Voz De La Feria.

La Romana
 Dominican Republic
 Controlled by crystal, on a frequency of 6730 kc., equivalent to 44.57 meters.
 Transmission Hours:
 Daily—12:30 a.m. to 2 p.m.
 6:30 p.m. to 8 p.m.
 Sundays—12:30 p.m. to 3 p.m.
 Owners: Roberto Palli Bernado
 Moises N. Garip

This Great Book Brings You RADIO'S GREATEST VALUES



**NEW 1937 ALLIED RADIO CATALOG
 RADIO'S LEADING SUPPLY GUIDE**

A new book!—a complete book!—a time-saving, money-saving book!—that's the new 1937 ALLIED Radio Catalog! 152 value-packed pages—10,000 tested and approved parts—hundreds of high quality, low-priced sets and kits—complete lines of the newest in Amateur, Service, and P. A. equipment—page after page of the latest tools, books, etc.—Everything in Radio at the lowest prices! You don't have to look any further; here, in one great book, are listed RADIO'S GREATEST VALUES.

**COMPLETE STOCKS—FASTER SERVICE
 —LOWER PRICES**

We carry complete stocks of Radio's choicest merchandise on hand at all times. No delays, no inconveniences—no matter what you need, we have it—when you want it. ALLIED's highly specialized organization fills, checks, packs and ships your order speedily and accurately. Our tremendous resources, our vast purchasing power, enable us to buy for less and pass the resulting savings on to you. Thousands of radio Amateurs, Dealers, Servicemen, Experimenters and Sound-men order from ALLIED regularly because they know they save time and money on every order.

**EVERY ITEM TESTED AND APPROVED
 —BY RADIO EXPERTS**

The new 1937 ALLIED Catalog brings you the benefits of world-wide search and research by skilled radio buyers, technicians, sound engineers, licensed Amateurs,—men expert in every field in Radio. We carefully check every item for quality, performance and price. Our wide experience in your protection—your assurance of high quality and lowest prices. Our technical staff is at your service in other ways, too—to recommend replacement parts, to furnish parts lists for kits, to check P.A. specifications—to give you friendly expert advice on every conceivable problem, without obligation. That's why ALLIED is known everywhere as "Radio's most Reliable Supply House."

No matter what your radio interest is, you need the new 1937 ALLIED Radio Catalog! If you don't have a copy of this great book send the coupon now! It's FREE!

**EVERYTHING IN RADIO
 —AT LOWEST PRICES**

- FOR AMATEURS**—A tremendous assortment of transmitters, receivers, and transceivers for every requirement.
- FOR SET-BUILDERS**—Dozens of new kits—metal tube DX'er, Super-Gainer, 6-volt all-wave set, 5-meter transceiver and many others.
- FOR SERVICE MEN**—Newest tube checkers, set-testers, analyzers, oscillographs, meters, Thousands of replacement parts, tools, books.
- FOR SOUND-MEN**—Latest P.A. equipment, 8-60 watts; permanent, mobile and portable, for 110 volts AC, 6 volts DC, and universal operation.
- FOR DEALERS**—Complete service equipment—38 astounding new radios from 5 to 19 tubes, as low as \$8.45. 6 volt, 32 volt, AC, AC-DC, battery and auto sets, Rarlpower units and Windchargers.



ALLIED RADIO CORPORATION
 833 W. JACKSON BLVD. CHICAGO

ALLIED RADIO CORP., Dept. 3-L
 833 W. Jackson Blvd.,
 Chicago, Ill.
 Please send me FREE 1937 ALLIED RADIO CATALOG

NAME.....
 ADDRESS.....
 CITY.....STATE.....

The New CARDWELL

**FOR ULTRA HIGH FREQUENCY
 BECAME POPULAR
 OVERNIGHT**

**BECAUSE
 IT IS
 FINEST**

It's designed especially for its job, tuning ultra high frequency circuits. Isolantite insulated, has minimum surface leakage losses, no closed metallic loops, low minimum capacity and has thick plates, buffed and polished with rounded edges. Condenser you can buy for 5 or 10 meter oscillators, short wave therapy machines and swell for neutralizing 211's, 203-A's, etc.

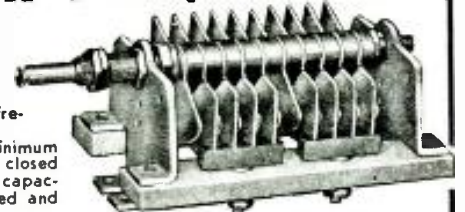

TYPE NP-35-GD \$3.60
 Amateur net
 35—5 M.M.F. Per Section—4000V.
 18—2.5 M.M.F. Stators in Series—7000V.
 ATR GAP—.084 Inches

Hundreds of other condensers for every purpose. Send for catalog

The Allen D. Cardwell M'g. Corporation
 89 PROSPECT ST., BROOKLYN, N. Y.

Please mention SHORT WAVE CRAFT when writing advertisers

UNCONDITIONAL GUARANTEE ON ALL OUR RADIO SUPPLIES
UNCLE DAVE'S
 RADIO SNACK
 356 BROADWAY-ALBANY, N. Y. U.S.A.

PEERLESS Super-Sensitive SHORT WAVE CONVERTER
 Makes a short wave superheterodyne of your present broadcast receiver. Operates with any type receiver. Self-contained power supply. Just plug in power cord and connect antenna and ground.
SPECIAL, complete ready to operate..... \$7.95

BLILEY crystals in stock:
 Type BC-3 \$3.95
 Type LD-2 4.80
 Type HF-2 7.50
TRANSMITTING TUBES
 Taylor T-55 \$8.00
 T-155 19.50
 Eimac 35-T 8.00

RED HOT SPECIALS

- Rebuilt 3" Jewell metal cased milliammeters. Ranges 0-100, 0-200, 0-300 ma. each \$2.50
- Oil-filled filter condensers
 5 mfd. 2000 volts, each 2.45
 3 mfd. 1200 volts, each 1.35
- Used Teleplexes with 3 tapes 9.95
- 4" Black bakelite dials, each10
 Special for this month only. 12 for \$1.00
- Kodak microphone cases. Suitable for any carbon microphone or can be used as a lamp \$.65
- Acme featherweight phones. 2000 ohm94
 4000 ohms 1.25
- Trimm featherweight phones 24000 ohm 5.88
- Brush crystal headphones, net 5.30
- 25,000 ohm 75 watt tapped bleeders25
- WEBSTER high impedance phonograph pickups 3.75

Latest communication type Amateur Receivers in stock. Write for trade-in allowance on your old receiver, and our time payment plan. Hallcrafters receivers, National, Hammarlund, RCA, etc.

SPECIAL CLOSEOUT

Peerless 3 tube Professional short-wave receivers. Complete with 2 sets plug-in coils, 3 tubes and hum free power supply.
Price complete \$13.75

- 5" Magnetic Speaker \$1.09
- 5" Dynamic Speaker 1.69
- 6" Magnetic Speaker \$1.69
- 6" Dynamic Speaker 2.45

Cable Address "Uncledave"
 Long Distance Phone 4-5746

Prices F.O.B. Albany Foreign Trade Solicited
 Send for new Ham Catalogue—just out!

Provision is also made for those who wish to use headphones in order to avoid disturbing others at late hours of the evening. This is accomplished by means of a so-called automatic phone jack, which is connected in the grid circuit of the 6F6G power tube. When the headphones are plugged into this jack, the power stage and the dynamic speaker are automatically disconnected from the receiver. Removing the phone plug automatically connects the speaker back into the circuit.

Other important features found in this set are the use of a *stage-aligning trimmer*, which is of prime importance in raising the sensitivity of the receiver to a maximum; a *volume control* which functions as a variable grid-bias control on the R.F. amplifier, thereby eliminating all possibility of the detector being overloaded and blocked on strong signals; an extremely smooth acting oscillation control, and a tone control. The latter feature, not only enables the tonal qualities of the set to be adjusted to suit the owner's preference, but is very useful in reducing certain type of noises present in every locality. All controls are adjustable from the front panel.

An inspection of the electrical circuit diagram discloses the use of a type 6K7G high-gain tube, as *tuned radio-frequency amplifier*, another 6K7G as high-gain screen-grid, electron-coupled regenerative detector, one 6C5G as first audio frequency amplifier stage, another 6C5G as second audio amplifier, one type 6F6G power pentode output stage, working into a dynamic loudspeaker, and finally a 5Y3 high vacuum full-wave rectifier. The G type of tubes are true glass tubes, equipped with the new octal bases, which permit the user to later change over to metal tubes if desired and without any changes whatsoever in the receiver itself.

Stage-Aligning Trimmer

The antenna system, *doublet or single-wire* antenna and ground, work into the primary winding of coil L1 (5 prong). The secondary winding is tuned by condenser C1, in parallel with which is a midget variable C2, used as a *stage-aligning trimmer*. Volume of signals is controlled by means of the variable control R1 (25,000 ohms with a minimum stop of 300 ohms). This control varies the bias on the R.F. stage and thereby constitutes a very effective means of controlling signal voltage input to the detector stage. Even the strongest of stations may be received without any trace of blocking of the detector tube, a fault common in many poorly designed short-wave receivers. Screen grid voltage on the R.F. tube is obtained through the resistor R2, which is so proportioned as to place that value of screen voltage on the tube as to give maximum sensitivity. The plate output of the R.F. stage is electro-magnetically coupled into the grid of the second 6K7G tube, functioning as an electron-coupled regenerative detector. Values of grid-leak and condenser of

ALL-ELECTRIC 3-TUBE, 4 IN 3 Bandsread Short Wave Receiver



A completely electrified receiver capable of world-wide reception. OWNERS REPORT RECEPTION OF AS HIGH AS 35 FOREIGN COUNTRIES. Uses 6F7 (twin 2 in 1 tube), 7B & 1V tubes in full 4 tube performance circuit as screen-grid regenerative detector, two stage audio frequency amplifier, rectifier & built-in hum free power supply. Completely self-contained. Illuminated, airplane type vernier dial. Nothing extra to buy. Sensitive, powerful, and operates a speaker on many stations. Has 3 black shrouded metal chassis, panel, and cabinet. Coils for 10-200 meters, and simple instructions furnished.

5
 KIT of parts, with 4 coils for 10-200 meters, ready to wire, less tubes, cabinet and B.C. Coils \$1.50
 Wired and tested, extra \$1.50
 Matched AIRCRAFTUS tubes (2) 1.95
 Beautiful, black finish metal case (not included) 1.25
 Broadcast coils (2) 1.00
SPECIAL: Complete kit, cabinet, 4 tubes, 2 BC coils, wired and ready to use..... \$10.95

BA-3 Three-Tube Battery Operated Receiver
HAS SAME APPEARANCE AND CONSTRUCTION AS ABOVE RECEIVER, except that it is operated entirely from dry batteries. Uses 32, 30, 31 tubes in powerful circuit as screen-grid regenerative detector, powerful 2 stage audio frequency amplifier with pentode output stage. Bandsread tuning. Uses one 2 volt A battery, one C battery, and 45 to 90 volts of B battery. Remotely operates a loudspeaker in full volume. SAME price as All-Electric model. (Less batteries.)
 Cannonball double headphones \$1.35. Magnetic speaker \$1.45

CENTRALLION ENGINEERING CO.
 Dept. SW11, 136 Liberty St., New York, N. Y.

Doerle 6-Tube "Band-Spread" S-W Receiver

(Continued from page 400)

"log" any short wave station with ease. Its use makes possible the separation of the "crowded" short-wave stations on any particular band over the entire face of the dial. Such accurate tuning is important in order to obtain the maximum possible tonal qualities from any receiver, as well as making tuning a positive pleasure. This type of dial is provided with two knobs on a concentric shaft. One knob is for fast tuning. The other knob operates the band-spread pointer at a ratio of approximately 125 to 1. The wavelength ranges of the coils shown below are: No. 1—8½ to 24 meters (M); No. 2—23 to 44 M; No. 3—43 to 90 M; No. 4—40 to 220 M; No. 5 (Broadcast)—220 to 600 M.

- ANTENNA COILS - (5-PRONGS)				
COIL NO 1	COIL NO 2	COIL NO 3	COIL NO 4	BROADCAST COIL
SEC - NO 18 GA COPPER WIRE 5 3/4 TURNS 3/16" SPACING (OR 5 TURNS PER INCH)	SEC NO 18 GA COPPER WIRE 11 3/4 TURNS 3/32" SPACING (OR 10 TURNS PER INCH)	SEC NO 24 GA ENAM WIRE 23 3/4 TURNS 3/64" SPACING (OR 22 TURNS PER INCH)	SEC - NO 20 GA ENAM WIRE 51 3/4 TURNS CLOSE WOUND (OR 45 TURNS PER INCH)	SEC - NO. 28 GA ENAM WIRE 124 3/4 TURNS CLOSE WOUND (OR 100 TURNS PER INCH)
PRI - NO 20 GA ENAM WIRE 5 3/4 TURNS CLOSE WOUND	PRI - NO 20 GA ENAM WIRE 6 3/4 TURNS CLOSE WOUND	PRI - NO 20 GA ENAM WIRE 9 3/4 TURNS CLOSE WOUND	PRI NO 20 GA ENAM WIRE 8 3/4 TURNS CLOSE WOUND	PRI - NO 28 GA ENAM WIRE 16 3/4 TURNS CLOSE WOUND
- DETECTOR COIL - (6-PRONGS)				
COIL NO 1	COIL NO 2	COIL NO 3	COIL NO 4	BROADCAST COIL
SEC - NO 18 GA COPPER WIRE 5 3/4 TURNS 3/16" SPACING (OR 5 TURNS PER INCH) TAPPED AT 2ND TURN FROM BOTTOM	SEC - NO 18 GA COPPER WIRE 11 3/4 TURNS 3/32" SPACING (OR 10 TURNS PER INCH) TAPPED AT 2ND TURN FROM BOTTOM	SEC NO 24 GA ENAM WIRE 23 3/4 TURNS 3/64" SPACING (OR 22 TURNS PER INCH) TAPPED AT 3RD TURN FROM BOTTOM	SEC - NO 20 GA ENAM WIRE 51 3/4 TURNS CLOSE WOUND (OR 45 TURNS PER INCH) TAPPED AT 4TH TURN FROM BOTTOM	SEC - NO 28 GA ENAM WIRE 124 3/4 TURNS CLOSE WOUND (OR 100 TURNS PER INCH) TAPPED AT 9TH TURN FROM BOTTOM
PRI - NO 20 GA ENAM WIRE 5 3/4 TURNS CLOSE WOUND	PRI - NO 20 GA ENAM WIRE 6 3/4 TURNS CLOSE WOUND	PRI - NO 20 GA ENAM WIRE 9 3/4 TURNS CLOSE WOUND	PRI - NO 20 GA ENAM WIRE 8 3/4 TURNS CLOSE WOUND	PRI - NO 28 GA ENAM WIRE 16 3/4 TURNS CLOSE WOUND

Winding Data for R.F. and Detector Coils

Please mention SHORT WAVE CRAFT when writing advertisers

INVENTORS

TIME COUNTS—don't risk delay in patenting your ideas. Write for new FREE book, "Patent Guide for the Inventor" and "Record of Invention" form. No charge for preliminary information.
CLARENCE A. O'BRIEN & HYMAN BERMAN
 Registered Patent Attorneys
 23-F Adams Building, Washington, D.C.

2,000,000 ohms and 0.00015 mf. respectively give excellent stability and freedom from all traces of oscillation howls.

The secondary circuit is tuned by means of the condenser C3 which is ganged with condenser C1, so as to form single dial control. Note that the cathode is connected to the proper tap on the coil L2, whereas the suppressor is grounded directly. The coil socket connections as well as the tube sockets represent bottom views of same. Regeneration is controlled by means of the potentiometer R5 (100,000 ohms) and having a specially tapered resistance characteristic. This control is connected in series with a fixed resistor R3 of 250,000 ohms. The latter resistor reduces the voltage across the regeneration control and causes an exceptionally smooth oscillation control.

Detector to First A.F. Stage Coupling

The output of the detector is resistance-capacity coupled into the grid of the first audio stage. Values shown on the diagram are very satisfactory for good energy transfer. Bias on this stage is obtained from the resistor R8 (2500 ohms). This stage is in turn resistance-capacity coupled into the grid of the second stage and using the electrical coupling constants as indicated on the diagram. Bias for this stage is obtained in the same manner as on the first. The output of the second 6C5G works into the grid of a power tube of the pentode type, i.e. 6F6G and which is capable of delivering a full 3 watts of audio power to the dynamic loudspeaker. The combination R13-C17-R14 is very important and prevents the occurrence of tunable hum originating in the audio stages. Values of 500,000 ohms, 0.1 mf., and 150,000 ohms respectively are highly satisfactory. Bias for the power stage is furnished by the 300 ohm tap on the speaker which also serves as the filter choke.

The combination C14 and R15 serves as the tone control and is of considerable use in cutting down on the noise level as well as providing a means of adjusting the tonal qualities to suit the individual's preference.

Full-Wave Rectifier Employed

A type 5Y3 full-wave rectifier is used due to its low internal voltage drop. Filter condenser C16 (dual 8 mf.) operating in conjunction with the field coil, reduces A.C. hum to a negligible extent. The switch "X1" enable the operator to cut the plate voltage off without disturbing the filaments of the receiver. This latter feature is of prime importance to those who wish to use the instrument as a communications receiver.

Capacity Cq (0.01 mf.) should be included as it prevents tunable hum which may otherwise arise. Switch "S" is used to turn the receiver on and off at will.

The entire receiver should be constructed in a heavy metal chassis (cadmium-plated for high electrical conductivity) and enclosed in a metal cabinet, (black shrivel lacquer finish). Overall dimensions of the completed receiver are only 17 1/2"x8"x8 3/4". Ample shielding, cadmium plated, should be included between the R.F. and detector stages, in order to remove the last trace of "interlocking" (coupling) between stages.

The selectivity and sensitivity of this receiver is remarkable. The volume on the majority of "foreign" stations is so great that it is necessary to cut down on the gain-control in order to maintain it at comfortable room volume. The author, using a 20 foot aerial, is able to receive numerous European, South American, and on numerous occasions stations as far away as Australia and Africa, with surprising loudspeaker volume. Used properly, and in an intelligent manner, there is no reason why even the "beginner" should not be able to obtain similar results.

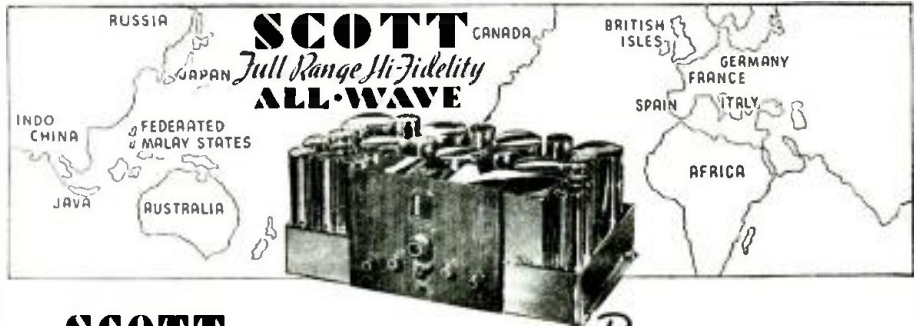

SCOTT PERFORMANCE Begins WHERE THE OTHERS STOP

● Here's a target for distance sharpshooters all over the world to level guns at! Here is proof that the SCOTT ALLWAVE is the finest receiver in the world!

From F. L. Stitzinger in Pennsylvania comes this verified list of 34 foreign countries, 98 foreign stations, 1651 foreign programs—not merely logged, but verified! All within a short six months period! No other receiver in the world has equalled this verified world record performance during any six consecutive months tuning!—Argentina, Australia, Belgian Congo, Bermuda, Bolivia, Brazil, Belgium, Canada, Columbia, Costa Rica, Cuba, Denmark, Ecuador, England, Federated Malay States, France, Germany, Hawaii, Holland, Indo-China, Italy, Japan, Java, Kenya Colony, Mexico, Morocco, Peru, Portugal, Republic Dominica, Russia, Spain, Uruguay, Venezuela! Every station, every program, verified!



E. H. SCOTT, designer and custom-builder of world's finest radio receivers since 1924

MR. SCOTT'S PERSONAL MESSAGE TO YOU

Says Mr. Scott: "Mr. Stitzinger's list is only one of thousands which SCOTT owners constantly send in to our laboratories—SCOTT owners receive and have verified 3 times as many foreign stations as are received on sets of other radio manufacturers... SCOTT ALLWAVE receivers are giving distinguished service in more than 146 countries throughout the world... We have over 600 expert installation and service representatives over entire United States alone—to give you instant service should you ever need it. This, even though every SCOTT receiver carries five year guarantee of perfect service."

FACTS ARE YOUR GUARANTEE

Here is reception not even approached by any other receiver anywhere on earth—regardless

of price! This is not "sales talk." These are vital facts—of deep interest to every DX enthusiast.

To enjoy the really great world music, to hear the tremendous events which are moulding history—still to be in tomorrow's headlines—you must have high Class "A" speaker power.

SCOTT 23 TUBE ALLWAVE has 35 Watts Strictly Class "A" Power, 50 watts Class "AB" power—6 times undistorted output of average receiver—for vaster distances.

Bullet-Direct Variable Selectivity 2 to 16 KC.—3 times better than selectivity of average receiver—to pierce through powerful local stations and bring in weak distant stations thousands of miles distant.

6 Microvolt Sensitivity—Twice that of any other radio receiver.

25 to 16,000 Cycle Hi-Fidelity—provably twice the tonal range of any other high fidelity receiver—a fact which we can demonstrate in any comparative test.

Dial Calibration—accurate on all tuning bands for the first time in radio history.

Foreign Station Locator—tunes in the short wave stations instantly.

More Important PERFORMANCE Features Than Any Other Receiver—including True Bass Control—True Separate Treble Control—23 Tubes, New Highest Efficiency Type—Oversize Construction throughout—Includes many advanced laboratory developments which cannot be incorporated in production type radio receivers.

Compare It in Your Home

These celebrities demand the world's finest quality—all are SCOTT owners—Toscanini—Guy Lombardo—Eddie Cantor—Walter Winchell—Ted Husing—Rudy Vallée—Al Jolson—and hundreds more. The SCOTT is the choice of Presidents and Princes all over the world.

Unqualifiedly guaranteed to bring you more foreign stations with stronger volume, with more crystal clear tone, with less noise than any other receiver in the world—in your own home! 30 days' trial. You can own the SCOTT for no more than you would pay for an ordinary receiver.

The Secret of Superiority

How is such an unequalled guarantee possible? The SCOTT is strictly custom-built—to highest precision standards known. Sent to you direct from laboratories—fully adjusted and proved, with nationwide installation service.

Read coupon below—NOW—and decide right now—without delay—to send for the most thrilling story of world-covering performance in the history of radio!

Visit our new permanent salon at 630 Fifth Ave., Rockefeller Center, New York City or 115 N. Robertson Blvd., Los Angeles, Cal.



SEND THIS COUPON TODAY—DETAILS FREE

E. H. SCOTT RADIO LABORATORIES, Inc.
4470 Ravenswood Ave., Dept. 2876, Chicago, Ill.

Send "94 PROOFS" of the SCOTT'S superior tone and DX performance, and particulars of 30-day home trial anywhere in U. S. A.

Name.....
Street.....
City..... State.....

Builder of WORLD'S FINEST CUSTOM-BUILT RADIO RECEIVERS Since 1924

CABINETS CHASSIS and PANELS
For any make receiver made to order

Send drawing, blue print, or give complete description and we will give you our lowest estimate. We enamel in plain or crackle finish, also nickel or chrome plating.

ALL SIZES STOCK CANS ON HAND
Dealers and Jobbers Write for Special Prices
KORROL MFG. CO., Inc. Dept. S-11
232 Greenwich St. New York City

See Pages 388 and 446 for Remarkable Subscription Offers



AMERICAN Microphone Co., Inc.

"GLOBE" C-5
Crystal Microphone
● Dual-Diaphragm
● Dual-Crystal
● Non-Directional

1915 South Western Ave., Los Angeles, Calif.

OHMITE BROWN DEVIL RESISTORS

enamel coating protects against failures. Ask your dealer or write.
OHMITE MFG. CO.,
4839 Flournoy St., Chicago, Ill.

Please mention SHORT WAVE CRAFT when writing advertisers

ACTUAL MODULATION PERCENTAGE SHOWN ON DIRECT READING SCALE



MODULATION MONITOR



MODEL 1295

Dealer Price \$24⁸³
FOR All Voice Transmitting Stations

Eliminates the uncertainty of depending on the ear, variation of antenna ammeter or the loop and light in determining carrier shift and percentage of modulation. Actual modulation percentage is shown on direct reading Triplet twin precision instrument. All readings in peaks. Scale indicates modulation from 40 to 120 per cent. Visual information on second dial provided for carrier reference level for the modulation test and also to check carrier shift during modulation. Factory calibrated and no further calibration needed.

Model 1295 MODULATION MONITOR Complete with necessary accessories Dealer price..... **\$24⁸³**

This is a Triplet Master Unit

See the Modulation Monitor at your jobbers. Triplet manufactures a complete line of precision Electrical Testing Equipment and precision Electrical Measuring Instruments for the amateur and experimenter. Complete information available on request.



The Triplet Electrical Instrument Co.
 2811 Harmon Drive, Bluffton, Ohio.

Without obligation please send me more information on Model 1295 Modulation Monitor

I am also interested in

Name

Address

City State

8-29-36

For the benefit of those who wish to construct the new Doerle 6-tube band-spread receiver, the following parts list is offered:

6-Tube Doerle—Parts List

- C1-C3—Tuning Condenser, two gang, .00014 mf. per section
- C2—15 mmf. Variable Midget Condenser
- C4, C5, C7, C8, C9, C11, C12—.01 mf. Tubular Condenser
- C6—.00015 mf. Mica Grid Condenser
- C10—.00025 mf. Mica By-Pass Condenser
- C16—Dual 8 mf. 500 Volt Electrolytic Filter Condenser
- C13, C14—.1 mf. Tubular Condenser
- C15—.1 mf. Tubular Condenser
- R1—Volume Control, 25,000 ohms, with 300 ohms stop
- R2—100,000 Ohm, 1 Watt
- R4—2,000,000 Ohm Grid-Leak, 1/2 Watt
- R5—Regeneration Control, 100,000 Ohm
- R3, R7—250,000 Ohm, 1/2 Watt
- R10, R6, R11—100,000 Ohm 1/2 Watt
- R8, R12—2,500 Ohm, 1/2 Watt
- R9—75,000 Ohm, 1/2 Watt
- R13—500,000 Ohm 1/2 Watt
- R14—150,000 Ohm, 1/2 Watt
- R15—Tone Control, 1/2 Megohm

- One metal chassis, shields, and cabinet
- One bandspread dial
- Six knobs
- One dynamic speaker, 1800 ohm field with 300 ohm tap
- One automatic jack
- One set 5 prong coils
- One set 6 prong coils
- One power transformer
- One 5 prong socket
- One 6 prong socket
- Six Octal tube sockets
- Two 6.3 volt pilot lamps, Mazda
- One switch
- 2—6K7G tubes (glass, with octal base).
- 2—6C5G tubes (glass, with octal base).
- 1—6F6G tube
- 1—5Y3 tube

Junior "Space-Explorer"

(Continued from page 401)

The shorter leads made possible with plug-in coils result in lower losses which, in the last analysis, are a deciding factor in determining the distance range of a receiver.

38 Pentode Used As Power Tube

The detector, VI, is resistively coupled to the first audio stage, which is also the power output stage. A 38 type pentode tube is used as the power tube. This has an undistorted power output of 1/2 watt on A.C., more than sufficient to drive the five inch magnetic speaker employed. The necessary cathode bias of 13 1/2 volts is obtained by means of the voltage drop across a 1,000 ohm resistor in series with the cathode circuit.

Provision is made for earphone reception, the twin phone-jack being located at the front of the panel. A metal 6C5 tube provides the necessary rectification. The economical A.C.-D.C. circuit employed permits operation of this receiver on any type of house-lighting circuit. An additional advantage is the fact that when this set is plugged into an A.C. circuit, it will operate on 25 or 40 cycles as well as on the more usual 60 cycles. Through the use of an inexpensive and easily applied adapter, the same receiver can also be used on 220-volt A.C. or D.C. lines as well as on standard 110 volt circuits. An inexpensive but efficient method of filtering is used. This eliminates the usual choke in the high-tension circuit, substituting a resistor, R7, by-passed at either end by sections of an electrolytic condenser. The cathode by-pass condenser, C9, for the power tube, V2, is enclosed within the same cardboard container as the filter condensers, C7 and C8.

Ballast Resistor Tube a New Feature

The Junior Space-Explorer introduces a new and desirable feature in the utilization of a metal ballast tube, V4. This contains the voltage reducing resistance required to reduce the line voltage to the exact value necessary for the heaters of the other three tubes. The ballast tube and the heaters of the tubes are connected in series across the 110-115 volt line. This new ballast tube has many advantages. It eliminates the line-cord resistor which constituted a fire hazard. It concentrates and localizes the heat necessary for the required voltage drop, keeping it away from delicate parts such as electrolytic condensers, but radiating it readily because of the metal construction. Added advantages of the ballast tube are the fact that it provides protection against over-voltage due to line surges, thus improving operation and increasing the life span of the other tubes. Furthermore, in case of a short-circuit, the ballast tube acts as an automatic fuse, opening the circuit and protecting the other tubes. Since it can be replaced at a relatively low cost and without any trouble whatsoever, merely by plugging in another tube, this feature alone makes

it a most valuable addition to the modern A.C.-D.C. receiver.

New Idea in Cabinets—Made of Wood

A new and noteworthy idea has been developed in the construction of the Junior Space-Explorer. Looking carefully at the front view illustration, one gets the impression that this receiver is housed in an expensive, factory-made metal cabinet of the "Professional-Communication" type. As a matter of fact, this cabinet is made of wood, painted with a new type of crystalline black lacquer. This is put on with a brush, just like any other paint or varnish, but when it dries, it crystallizes, producing a beautiful crackle finish equal or superior in appearance to finishes

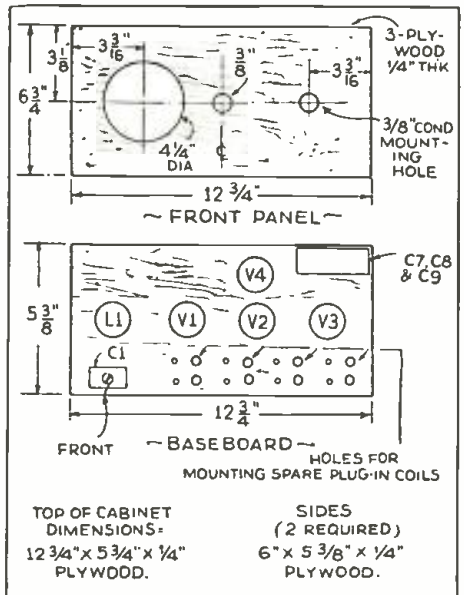

sprayed on metal by professionals. The wood cabinet can be made at very low cost from 1/4" plywood which, of course can be obtained almost anywhere, cut to the desired sizes. After being nailed with thin brads or glued together, and painted with the crystalline lacquer, the finished product provides a housing for the receiver which not only costs much less than a metal cabinet, but also is far superior in many ways.

Years ago, when radio was in its infancy, the metal cabinet was standard equipment with many manufacturers. As radio and acoustical knowledge progressed, however, the metal cabinet was soon discarded in all broadcast receivers, in favor of wood, until, at present, only short-wave sets are encased in metal cabinets. Up to about a year ago the metal cabinet served a definite purpose in a short-wave receiver, since it acted as a shield. With

Please mention SHORT WAVE CRAFT when writing advertisers

the advent of the metal tubes, this type of shielding is no longer necessary. Hence, the metal cabinet has outlived its usefulness and its retention at present is due to a type of inertia which often accounts for lack of progress.

The wood cabinet of the Junior Space-Explorer acts like the sounding board of a violin, making the loud-speaker tones richer and fuller and eliminating the tinny effect so noticeable with a metal cabinet. Glancing at the front view, one is impressed with the dignified simplicity of the controls. The station selector bar-knob at the right is located in a natural position for easy tuning. The combined switch and regeneration control is in the center of the panel, between the speaker and the station selector. Below this, is the earphone jack, in a conveniently accessible position.

In constructing the Space-Explorer, the first step is to nail the panel to the base-board. Since the latter is of wood, no sub-panel or additional chassis is required. The five sockets are fastened to the base-board by means of wood screws with the coil socket nearest the variable condenser. The coils not being used are inserted in holes drilled for them at the rear of the baseboard. The antenna trimmer is also fastened to the baseboard near the coil socket. The variable condenser, potentiometer, speaker and phone jacks are mounted on the panel. Other parts, such as fixed resistors and condensers, are soldered in place near the terminals of the parts with which they function, this being done as the set is wired. Due to the extreme simplicity of the circuit, no skill or experience is required to produce a perfect job.

List of Parts for Junior "Space-Explorer"

- HAMMARLUND**
 C1—Antenna Trimmer, 10 to 70 mmf. type MICS-70.
 C2—Midget Variable Condenser, type MC-140-M.
 L1—One set of four prong Short Wave Coils, 17 to 270 meters, type SWK4.
 I.1—One four prong Broadcast Coil, 250 to 560 meters, type BCC4.
- CORNELL-DUBILIER**
 C3—.0001 mf. Mica Condenser, type 3L.
 C4—.1 mf. 400 volt "Cub" tubular Condenser, type BA-4P1.
 C5—.0005 mf. Mica Condenser, type 1W.
 C6—.01 mf., 400 volt "Cub" tubular Condenser, type BA-4S1.
 C7, C8, C9—dry Electrolytic Condenser, card-board container, three sections, section C7—4 mf., section C8—8 mf., section C9—5 mf. type MA-11117, 150 to 200 volts.
- MISCELLANEOUS**
 R1—1 meg. 1/2 watt Metallized Resistor
 R2—1 meg. 1/2 watt Metallized Resistor.
 R3—50,000 ohm Potentiometer and switch (SW1), type P-185, 50,000.
 R4—175,000 ohm, 1/2 watt Metallized Resistor.
 R5—1 meg. 1/2 watt Metallized Resistor.
 R6—1,000 ohm, 1 watt Metallized Resistor.
 R7—5,000 ohm, 1 watt Metallized Resistor.
 One four-prong Wafer Socket for Plug-in Coils.
 Three octal Wafer Sockets for metal tubes.
 One five-prong Wafer Socket for 38 tube.
 V4—Ballast Metal Tube, type K105-A. Res. 350 ohms, current rating 50 watts. (Name of manufacturer furnished on request.)
 One Roll push-back hook-up wire.
 SW1—Switch on R3.
 (SW1), type P-185, 50,000.
 J1, J2, Twin earphone Jacks.
 1—Five-inch Find-All Magnetic Speaker.
 2—4 3/4" diameter ornamental Metal Rings for dial and speaker.
 1—Calibrated Dial.
 1—Bar Knob, two small control knobs.
 Cloth grille for speaker opening.
 Wood baseboard, panel, cabinet top and sides (see sketches).
- GENERAL CEMENT MFG. CO.**
 1—jar Crystalline black lacquer.
- RCA RADIONRON**
 V1—6J7 Tube, RCA Radiotron.
 V2—38 Tube RCA Radiotron.
 V3—6C5 Tube, RCA Radiotron.

A MARINE MODEL T.R.F. RECEIVER



Sargent Model 11

We believe Model 11 to be the finest receiver of its type ever built. Take a look "under the hood" and see how well it is put together. Note the neat, business-like appearance on top of the chassis,—the arrangement and freedom from crowding underneath. The coil unit under the chassis, covering 9.5 to 3750 meters, has individual stage shields, and the entire unit is spaced 1/4" off the chassis, confining coil currents to the unit itself. The coil unit above the chassis, 3750 to 20,000 meters, is of similar construction. I.F. and detector tube bases, and their associated parts are shielded from the rest of the receiver by the coil unit, with all circuits isolated. With well-designed, space wound coils inside these units, and Litz-wound hexcombs for long waves, the reason for the receiver's efficiency is apparent.

Model 11 is available in 3 tuning ranges, and for A.C., D.C. and battery operation on all three. The D.C. and battery models are carefully designed and are real performers. Model 11 uses 5 tubes, one R.F. stage, regenerative detector, 76 audio driver, 42 output, and an 80 rectifier.

Most experienced operators prefer the extreme sensitivity and quiet efficiency of the T.R.F. receiver, especially for C.W. It takes a T.R.F. set, with its lack of tube noise, to get those real weak signals from distances not commonly heard on the larger receivers.

Increase your radio enjoyment 100 fold with a Marine or Universal tuning range receiver,—something more than just an amateur receiver. Be there, in 600 meters, for the next SOS,—cover the beacon, navy, time signal and press waves, and give your station efficient all-wave coverage. When you get tired of the 40 meter C.W., switch to 36 meters and hear the ships from the Mediterranean to "west of Penang" and "south of Pernambuco." Thrill? And how!

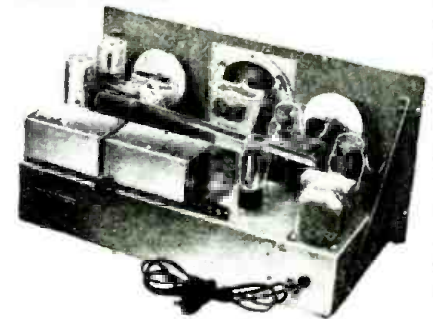

By "Well-Built" we mean this

- Model 11 Net Prices for 110 V. 60 cycles operation**
 Model 11-1A, UNIVERSAL tuning range, 9.5 to 20,000 meters.....\$75.00
 Model 11-1MA, MARINE tuning range, 9.5 to 3,750 meters.....\$54.00
 Model 11-1AA, AMATEUR tuning range, 9.5 to 550 meters.....\$46.00
 Prices include power supply, speaker and R.C.A. tubes. IMMEDIATE DELIVERY.
 Model 11 is available in all A.C., D.C., and battery voltages.
 Write for full description.

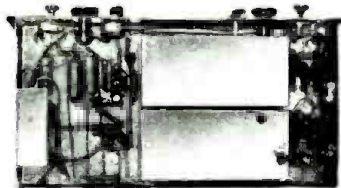

Model 11—Bottom View

E. M. SARGENT CO.

212 9th St. Oakland, Calif.

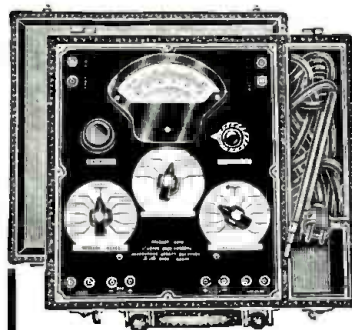

TWO LEADERS IN METERS



Dependable Master Multitester for only \$31.50

One Meter Does the Work of 41
 A portable testing instrument superior in range, accuracy and convenience. Costs much less and does much more than any other testing instrument in this field.
 Measures resistance from 1/4 ohm to 40 million ohms in 6 ranges. Capacity from .0001 to 200 mfd. in 5 ranges. AC & DC milliamperes from 10 microamperes to 2 1/2 amperes in 6 ranges. AC & DC voltages from 1/10 volt to 1000 volts in 5 ranges. Inductance in 5 ranges and decibels in 4 ranges. Employs a new and highly improved method of making A.C. measurements.
 A splendid meter for output measurements.

Dependable Volt-OHM-Milliammeter only \$8.75

An eight range instrument for economy without sacrificing accuracy. Compact and convenient to take out for general test purposes.
 D'Arsonval meter accurate within 2% direct reading in ohms, volts and milliamperes. Low ohm scale reads 12 ohms at center of dial, enabling less than 1/4 ohm to be measured easily. Smooth zero adjustment for high and low ranges. Furnished with self contained batteries.
 Ohms .0/1000/100,000
 DC Volts0/25/25/125/750
 DC Milliamperes0/2.5/125

Write today to Dept. 5-11 for an attractive circular describing the latest and most improved CATHODE RAY OSCILLOSCOPE.

See your jobber or write direct to

RADIO CITY PRODUCTS CO.
 88 PARK PLACE NEW YORK CITY "DEPEND ON DEPENDABLE"

Girl Operators, Attention!
 Listen "YL's" and "XYL's"! Why not send the Editor a good photo of your "Rig"—and don't forget yourself. A separate photo of yourself will do, with a "clear" photo of that station! \$5.00 for best "YL" photo.—Editor. See page 649 March issue for details.

Manufacturers of
VITREOUS TRANSMITTING GRID LEAKS
VOLUME CONTROLS - POWER RHEOSTATS
 Write for Complete Free Catalog
ELECTRAD, Inc.
 1/5 Varick Street, New York

OXFORD NEW SPEAKERS
 ... with "Changeable Fields" and Universal Transformer, bring you new convenience, performance and economy in Speaker Replacements. Ask your Jobber or Write today for Bulletin 3615.
OXFORD-TARTAK RADIO CORP.
 917 W. VAN BUREN ST., CHICAGO, U.S.A.

CROSLLEY NEW 1937 RECEIVERS

... BRING YOU THE BEST IN
SHORT WAVE RECEPTION

If there is such a thing as the "last word" in radio reception, CROSLLEY has it in the new 1937 Crosley Receivers. Short Wave enthusiasts have a new thrill awaiting them when they hear these new Crosley Models—for here is short wave reception as you have never before heard it.



CROSLLEY MODEL 1516 CONSOLE

Fifteen Tubes . . . Three Bands . . . 16 to 50 meters, 50 to 160 meters, 160 to 555 meters . . . Octal-Base, Metal Tubes . . . Auto-Expressionator . . . Cardiac Unit . . . Mystic Hand . . . High Fidelity . . . Triple-Twin Push-Pull Output . . . Illuminated, Full Vision, Magna-Ceramic Dial . . . Band Indicator on Dial . . . Vernimatic Dial Drive . . . Time Log Tuning . . . Fidelity Control . . . Multivox Control . . . Automatic Volume Control . . . Vibracoustic Sounding Board . . . 15" Curvilinear Speaker . . . **\$167.50**

SIXTEEN BRAND NEW MODELS

Distinctive modern cabinets . . . 5 to 15 tubes . . . two and three wave bands embracing a range from 16 to 555 meters . . . featuring the exclusive Crosley Auto-Expressionator that restores the full volume of expression normally suppressed in broadcasting; the Mystic Hand that automatically tunes your receiver to the exact frequency; the Multivox Control and 10 other advanced Crosley features—all of these are to be found only in the new 1937 Crosley Radios. See and hear them today at your Crosley dealer's.

POPULAR SHORT WAVE CROSLLEY MODELS

Table Model 715—(16 to 555 m.)—7 tubes.	\$ 44.95
Table Model 714—(16 to 555 m.)—7 tubes.	44.95
Console " 739—(16 to 555 m.)—7 tubes.	59.95
" " 709—(16 to 555 m.)—7 tubes.	69.95
" " 908—(16 to 555 m.)—9 tubes.	89.95
" " 1199—(16 to 555 m.)—11 tubes.	99.95
" " 1211—(16 to 555 m.)—12 tubes.	117.50
" " 1313—(16 to 555 m.)—13 tubes.	137.50

The CROSLLEY RADIO CORP.
CINCINNATI, O.

POWEL CROSLLEY, Jr., President
Home of "the Nation's Station"—WLW
70 on your dial—and Short Wave
Station W8XAL—49.5 meters.

YOU'RE THERE WITH A
CROSLLEY

New Short-Wave Sets and Devices

(Continued from page 409)

Lowest-Priced S-W Receiver

tice-wound Find-All coils, which can be seen on the upper part of the panel. Tuning is accomplished by means of a telescope-type metal tube variable condenser.

Due to the fact that the efficient 30-type tube requires very little current, the batteries which cost little to start with, will last for a long time under normal usage. An ordinary antenna, consisting of a single wire, is all that is needed for excellent reception.

An examination of the schematic diagram reveals a number of novel departures from conventional design, each one incorporated in the receiver for the purpose of improving performance and efficiency. For example, the use of an antenna trimmer not only permits direct coupling to the grid, but also gives increased selectivity almost equivalent to an extra r.f. stage. The two coils are tuned by the special metal-tube variable condenser. A unique arrangement permits these coils to be used separately or to be connected either in series or in parallel. This considerably increases their wave-length range. It will be seen that coil No. 1 is permanently connected to the grid side and that its other end terminates in the flexible wire "A." One end of coil No. 2 is permanently connected to the ground side and each end is also soldered to a clip, labelled respectively "C" and "D." A flexible lead "B" coming from the grid side is also brought out near the two clips.

To connect both coils in series between grid side and ground, it is simply necessary to connect flexible lead "A" to clip "C." To connect the two coils in parallel, "A" is connected to "D," and "B" is connected to "C." If it is desired to use coil No. 1 only, "A" is connected to "D." Coil No. 2 can be used alone by connecting "B" to "C." This may sound complicated, but in actual practice the flexible wires can be connected to or disconnected from the clips in a few seconds.

Standard grid-leak detection is used in this circuit and a 40-ohm rheostat provides a means of adjusting the filament voltage as the "A" batteries become weaker.

For the benefit of beginners, the designer of this receiver has originated a remarkable new method of showing how to assemble and wire the set. The exact location of all parts and of all wiring is printed on a sheet of paper, of precisely the same dimensions as the panel. It is a simple matter to fasten the sheet to the underside of the panel, mount the parts over the exact locations shown on the sheet and then connect these parts by hook-up wire, as shown by the heavy black lines on the printed sheet. This new method is fool-proof and the merest novice is thus assured of complete success in putting the kit together, and getting it into operation.

Constructing a radio set in this manner is of distinct educational value to the beginner. In fact, the Air Scout Junior line includes four more receiver-kits. These can all be built on the 8½" x 11" panel and each successive set represents a gradual advance in radio knowledge. Thus the completion of all five sets constitutes the equivalent of a practical course in the fundamentals of radio.

For example, it is possible to change the Air Scout Junior broadcast receiver into an All-Wave job capable of bringing in not only standard broadcasting, but also foreign stations, amateurs, code and all the other thrilling transmissions. This is accomplished merely by substituting plug-in coils for the Find-All coils and making a few other inexpensive changes. The same tube and batteries are used.

Progressing still further, two more stages of amplification can readily be added, thus making the broadcast receiver or the all-wave set capable of full loud-speaker operation on all stations. The set can also be constructed for all-electric operation. Each one of these sets employs the easy new method of showing where the parts belong

and how to connect them together. In addition, detailed instructions are furnished with all kits.

This article has been prepared from data supplied by courtesy of Allied Engineering Institute.

New "Mike" Spring Mounting

CASE
SPRINGS

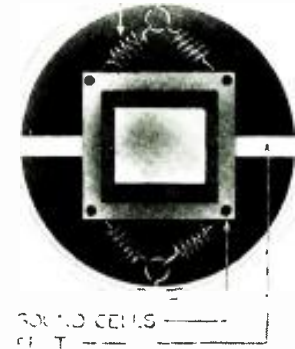

New Spring-mounting for microphones.
(No. 580)

● THE latest development in microphone construction tending toward quietness in use is the newly developed spring mounting in the BR2S microphone. This mounting makes unnecessary any external mounting ring or rubber stand shock absorber.

This device enables anyone using the microphone to pick it up and move it when in use. It is formed by fastening springs to two opposite sides of the unit of sound cells and pieces of felt on the other two sides. This makes the instrument unresponsive to jarring or other rough handling.

Because of this feature the BR2S is ideal for public-address work, in which the microphone is likely to receive particularly hard treatment. It has been extremely popular with conventions this summer, because it does not pick up extraneous noises.

This article has been prepared from data supplied by courtesy of The Brush Development Co.

New Multi-Wave Coil Assembly

(Continued from page 409)

directly to respective gang wipers. Air dielectric trimming condensers are used on all bands, except the ultra high frequency band which requires no trimmer. This arrangement operates with a standard three-gang 410 mmf. low minimum capacity condenser assembly.

The tubes recommended are as follows: 6K7, R.F. amplifiers; 6L7, detector; and 6J7, pentode oscillator. The 6K7 R.F. amplifier is employed on all bands except in the ultra high frequency region. The intermediate frequency suitable to this unit is 456 kc. The drawing clearly indicates the general appearance and method of assembly.

This article has been prepared from data supplied by the Meissner Mfg. Co.

New Bi-polar Head-Set

● UNQUESTIONABLY short-wave "Fans" and amateurs are the greatest users of headphones and they should be very much interested in this new President Cannon-Ball headphone. These are very efficient and are constructed with a bi-polar magnet unit. They are claimed to be unusually sensitive and light in weight and very

Please mention SHORT WAVE CRAFT when writing advertisers



The new "President" head-phones; they are available in impedances as high as 25,000 ohms. (No. 581)

rugged mechanically. The cases are of aluminum with hard composition caps; the easily adjustable head-band which is very flexible and leather-covered, makes this an ideal head set. These phones are available in three styles: one 2,000 ohm D.C. resistance, 10,000 ohms impedance at 1,000 cycles; another 3,000 ohms D.C. resistance, 15,000 ohms impedance at 1,000 cycles; and finally 5,000 ohms D.C. resistance, 25,000 ohms impedance at 1,000 cycles. The neat appearance of these new earphones is clearly illustrated in the photo.

This article has been prepared from data supplied by courtesy of the C. F. Cannon Co.

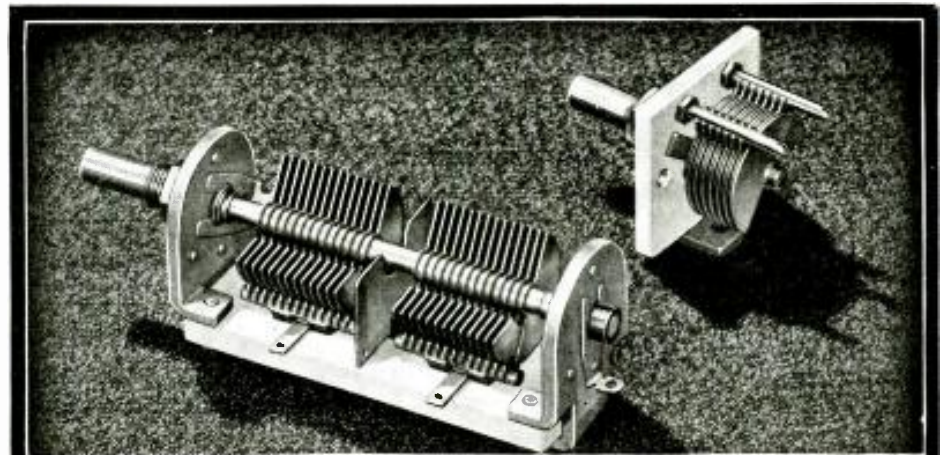

THE NEW "HF" VARIABLE CONDENSERS

An outstanding new series of ultra-high frequency variable condensers with a score of advanced exclusive features guaranteeing peak efficiency as trimming or tuning condensers for critical ultra-high frequency work. Single and dual types have cadmium plated soldered brass plates and B-100 isolantite insulation to insure lowest losses, rigidity, and stability. The single unit allows three different mounting methods—bracket, single hole panel mount, and panel mount with spacer bushings for complete insulation of rotor and stator. Absolutely noiseless operation is another feature, viz.—dual model has split rear bearing with individual noiseless wiping contacts for each section. Movable rotor contacts allow shortest possible leads. Single model sizes from 15 to 140 mmf. with a double spaced 30 mmf. available too. Dual sizes from 50 to 140 mmf., also a 30 mmf. double spaced model.

Write Dept. SW-11 for special "HF" booklet today

THE HAMMARLUND MANUFACTURING COMPANY, INC.
424-438 WEST 33RD STREET, NEW YORK CITY

HAMMARLUND'S 25TH YEAR

Book Reviews

PHENOMENA IN HIGH-FREQUENCY SYSTEMS, by August Hund. Cloth bound, size 6 1/2 x 9 1/4", 642 pages, 359 illustrations, with an appendix of useful formulas and tables, and a cross-index to the important subjects in the book. Published 1936 by McGraw-Hill Book Company, New York.

This newest work by August Hund is one that will rate the undivided attention of radio students and engineers for many years to come. This book is a very ambitious one, and every conceivable action occurring in vacuum tube circuits is discussed with mathematical analysis and formulas covering such phenomena. Other important subjects covered are the theory of the ionized layer, commonly known as the Heaviside-Kennelly layer, with an analysis both mathematical and otherwise of the reflection and refraction phenomena taking place when waves of different frequencies strike the various ionized layers in the ionosphere, including the subject of "selective absorption."

An excellent chapter is given on the electro-magnetic wave theory, a subject which is ever fresh to the earnest radio student, especially short-wave "Fans" and "Hams." This includes the study of wave radiation from antennas, ground penetration of the waves, etc. Another section deals with the theory of "electrostriction," with a discussion of the different forms of crystals and cuts.

MEASUREMENTS IN RADIO ENGINEERING, by Frederick Emmons Terman, Sc.D. Size, 6 1/2 x 9 1/4 in., cloth bound, 400 pages; over 200 illustrations and diagrams. Published by the McGraw-Hill Book Co., New York.

Every radio student needs this most important and timely work by Dr. Terman. The author's method of explaining each step in the work is very clear and complete, and includes a treatment of the cathode-ray tube in its many phases, which makes the treatment thoroughly up-to-the-minute.

The measurement of frequency is discussed by the author at length, and then we come to a study of vacuum tube characteristics, and the methods of measuring these characteristics. Audio frequency amplification is covered from a new angle, and then

comes measurements, including the performance and testing of different parts of a receiver; the method of using signal generators, etc.

Another section deals with oscillator and power amplifier measurements, measurements on radio waves, antennas, and transmission lines, etc. A valuable chapter is devoted to laboratory oscillators.

OFFICIAL RADIO SERVICE HANDBOOK, by J. T. Bernsley, 6x8 3/4 inches, cloth covers, 1,008 pages, 1050 illustrations. Published by Gernsback Publications, Inc., New York, N. Y. 1936. Price \$4.

At last a really complete treatise for the radio serviceman and all others interested in the operation, testing, and repair of radio receivers. The author, well-known to the radio fraternity, has provided a wealth of educational matter, commencing with such subjects as Circuit Fundamentals; Intricate Tuning Circuit Fundamentals—including instructions on how to "align" the various circuits in modern superheterodynes, converters, etc.

Later chapters concern themselves with such important subjects (with diagrams and clearly written explanations) as Volume and Tone Control, "AVC," and Resonance Indicator Circuits. Then we find Receiver, Audio Amplifier, and Power Supply Systems discussed in a refreshingly lucid style, with plenty of elementary diagrams to render the subject understandable. Loudspeakers, Pickups, and Phonograph equipment are treated in a complete and clear manner.

All the different types of commercial test equipment, which the modern serviceman must thoroughly understand and know how to use, are discussed at length, with pictures and diagrams of the various "test sets," including the Cathode-Ray Oscillograph and practical applications of it to modern set testing. Other vital subjects covered are: Auto Radio Installation and Service, All-Wave High Fidelity Receivers, Modernizing and Improving Receiving Sets, etc. A large section is devoted to a tabulation of data on commercial receivers, including their I.F. values, loud-speaker field resistance, voltage-divider data, and grid-bias resistors and tube types for all the leading sets.

A copious index, also wire tables, etc., is found at the end of the book.—H.W.S.

Prices Reduced

BLILEY BC3 CRYSTAL UNITS

40-80 METER BANDS

Supplied to exact specified frequency*

* integral Kc's. only
At all Bliley Dealers

Now \$ 4.95
(WITHIN 5 K.C.---\$3.95)

5 NEW HALLICRAFTERS SHORT WAVE RECEIVERS
★ SKY BUDDY ★ ULTRA SKY RIDER
★ SKY CHIEF
★ THE NEW SUPER SKY RIDER
★ SKY RIDER COMMERCIAL

NOW ON TIME PAYMENTS!

See these splendid new communications receivers at your jobbers today! They have every modern feature and are priced to suit every pocket book. Ask your jobber about the Hallicrafters Time Payment Plan.

the hallicrafters, inc.
Dept. SW
2611 Indiana Ave., Chicago, Ill.

GENERAL CEMENT



CRYSTALLIZING LACQUER

This crystal lacquer is especially adapted to provide a professional and finished appearance to all radio apparatus, such as: radio panels, chassis, test panels, analyzers, etc. Easily applied, is fast drying, air drying, and requires no baking. It can be used on all surfaces.

List Prices—2 oz. black 35c—2 oz. red, green, blue, brown, yellow 45c. Pint of black \$2.00. Pint of colors \$2.25.

See your radio jobber—if he cannot supply you, write us. Send for free circular of other radio needs.
GENERAL CEMENT MFG. CO. Rockford, Illinois

Please mention SHORT WAVE CRAFT when writing advertisers

RADIO INSTRUCTION

You Can Become a Fast, Capable RADIO OPERATOR at Home



Learn Code **THE WAY YOU WILL USE IT ON THE AIR**—Like **THE CHAMPIONS** who Were Trained By **The CANDLER Exclusive SOUND System.**

CANDLER Home Training Prepares you quickly, inexpensively to obtain your License, to build and operate your own Amateur Station expertly. With this exclusive training the new Code Speed requirement will not bother you. We train you to read code as easily as you read print.

CANDLER Trained McElroy, Champion Class A, Speed 69 wpm.

CHAMPION McELROY, who teaches CANDLER SYSTEM at HARVARD, says: "Practice alone, of any kind, will not develop skill and speed. It takes a thoro knowledge of the fundamentals and Mind Training, taught exclusively by **THE CANDLER SYSTEM.**"

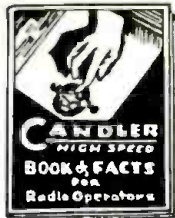

Amateurs and operators to hold good telegraph jobs for a quarter century. Ask fast Amateurs and com'l Radio ops. about **CANDLER. They know!**
FREE—New BOOK of FACTS—Contains information on New Code Speed Requirements. McElroy and little Jean tell you how they learned code and became champions. Whether you want to learn code or increase your speed, this book will aid you. All your questions answered. No obligation. No Expensive Practice Equipment Needed.

CANDLER SYSTEM

Dept. S-11., Asheville, North Carolina



CANDLER Trained 9 Year Old Jean Hudson, Champion Class E, 30 wpm.

CANDLER Will Train You In Everything Necessary To Obtain Your License.



Radio Amateur Course

(Continued from page 411)

cases for ultra-high frequency circuits of this type), the other side of the heater is by-passed immediately at the tube socket. The same is true of the screen-grid. While in the diagram Fig. 7 we show a single by-pass condenser with the two screen-grids connected together, it is advisable to employ two condensers—one for each grid. Various methods of coupling the antenna to these circuits have been shown and will depend entirely upon the antenna and feeder system employed in the transmitting station.

Handy Tester for Experimenter and Service Man

● **THE multimeter** shown in the accompanying photograph embodies all of the features necessary for an ideal unit to fill the experimenter's needs. This instrument includes the following test ranges: 0-50, 0-200, 0-750 volts. The sensitivity of the meter is 2,000 ohms per volt. The resistance meter ranges include all values from 1/4 ohm to 2 megohms. The batteries used in conjunction with the resistance measurements are contained within the unit. This instrument will measure current from zero to 50 milliamperes or in microamperes from zero to 500. It includes a 3/4 inch D'Arsonval moving coil meter with an accuracy of 2 per cent. Any of the previously mentioned test circuits are available individually, by merely changing the position of the selector switch. These positions are all accurately etched on a plate to facilitate operation. An especially designed compensator insures smooth zero-adjustment on all ohm-meter ranges. The Multimeter measures 5x8x3 inches, and weighs only 2.5 pounds.



WAKE UP! FELLOWS!

\$20.00 Prize Monthly for Best Set

● **THE editors** are looking for "new" receiving circuits—from 1 to 5 tubes preferably. A \$20.00 monthly prize will be awarded to the best short-wave receiver submitted. The closing date for each contest is 75 days preceding date of issue (Oct. 15 for the Jan. issue, etc.) In the event of a tie, an equal prize will be given to each contestant so tying. Address all entries to: Editor, **SHORT WAVE CRAFT**, 99 Hudson St., New York City.

T. R. McELROY
WORLD'S CHAMPION RADIO TELEGRAPHER
23 Bayside Street, Boston, Mass.
MAC KEY @ \$7.95 a real speed key.
MAC KEY DELUXE @ \$15.00 U.S.N. Spfn.
MAC CORD @ \$1.00 U.S.N. Spfn speed key cord.
MAC CASE @ \$3.95 U.S.N. Spfn speed key case.
MAC OSC @ \$3.95 ac/dc oscillator. Tone control.
If u hv Mac Key wri me to fomy ipr & dsrb ifn.
All my stuff emcy gad best pduts obl. 73 Mac.

YOUR CODE—IS IT FAST? COMPLETE?

Radio amateur Code exams are made by a "code speed" test. The **INSTRUCTOGRAPH** is the most practical method for beginners to learn code, and experts to develop speed. When you own your own **INSTRUCTOGRAPH** you can practice any time, at any speed desired. Comes in two models—Senior or Junior. **THE TEACHER** is the complete Book of Instructions. You can buy or rent, or have sent, and material for complete details now to—

INSTRUCTOGRAPH COMPANY
Dept. SW-11
912 Lakeside Place
Chicago, Ill.

Canadian Representative:
Radio College of Canada, Ltd.
863 Bay St., Toronto

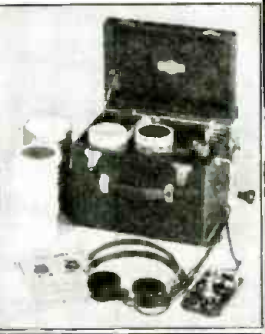

Here's the "Key" to SUCCESSFUL SERVICING

FOR MEN WHO WANT TO GET AHEAD!

Radio Service work is becoming more and more complicated. Technical training is a necessity if you expect to advance. Smart men are insuring their futures by training **NOW**. **GOOD** men always have **GOOD** jobs. Study at home and be ready to go ahead as a trained Service Technician.

COMPLETE HOME STUDY TRAINING FOR PROFESSIONAL SERVICEMEN

A complete, up-to-date course in Advanced Radio Service and Public Address Work, with or without Television. Terms as low as \$5 monthly. Write for details now.

FREE!

Interesting illustrated booklet complete in details regarding your future and our courses. Write for your own **FREE** copy today.

Be a TELEVISION EXPERT

LEARN TELEVISION with RADIO—NOW!

Great opportunity for experts in this amazing new industry. Recent developments in radio make television a certainty **NOW**. We teach you by our "on the job" method Radio and Television from beginning to end in our marvelously equipped labs and studios. You actually operate thousands of dollars worth of expensive equipment. You get expert instruction and skillful guidance by radio-television specialists.

Demand for Television Experts

Television now perfected and ready for the market **ON THE NEXT BIG BUYING WAVE**. Business leaders predict new system television will require thousands of relay and broadcasting stations. Ultra-short waves will permit eighty thousand television stations in America alone.

GET IN NOW and build up with the world's next billion-dollar industry.

6 MONTHS THOROUGH PRACTICAL TRAINING

Qualified for radio-telephone service. The Class Councils operate remote control room, "workable" television equipment including the new cathode ray. Practical experience in studio control room. Transmitter operation of Television Station **WHAAL**. Employment and while training and upon graduation. Write for free book "Pictures On the Air" **NOW!**

FREE BOOK

S. Q. NOEL, Pres. First National Television, Inc.
Dept. B-11, Power & Light Bldg., Kansas City, Mo.
Without obligation, send me postpaid **FREE** illustrated Book—"Pictures On the Air," telling about new opportunities in television. I am 17 years or older.

Name _____
Address _____



RADIO SERVICE INSTITUTE
Subsidiary of CREI
DEPT. SW-11, 3308 14TH ST. N.W., WASHINGTON, D.C.

Please mention **SHORT WAVE CRAFT** when writing advertisers

RADIO INSTRUCTION

HOW TO LEARN CODE

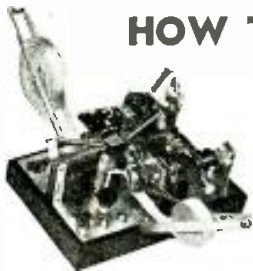

TELEPLEX has taught Code to more operators in past few years than all other methods combined. YOU can learn Code—or step up your w. p. m. amazingly — this

sure way. No experience needed. Beginners, amateurs, experienced ops get ahead faster with Teleplex. It doesn't merely "show" you code—it IS Code! You actually HEAR dots-dashes any speed you want. SENDS BACK your own key work in visible dots and dashes.

For quicker license find out about this better way. We furnish you complete course, lend all equipment. Including the new all electric Master Teleplex, give personal service on MONEY-BACK GUARANTEE. Low cost, easy terms. Without obligation write for booklet 8, 11.

"HAM" SPECIAL STANDARD TELEPLEX

A highly efficient code teacher using heavy specially prepared waxed paper tape, having two rows of perforations. Write for Free folder SW 11.

We are the originators of this type instrument.

TELEPLEX CO.

72-76 Cortlandt St. New York City
TELEPLEX—The Magic Key of the Air Ways

RADIO ENGINEERING

broadcasting, aviation and police radio, servicing, marine radio telegraphy and telephony, Morse telegraphy and railways accounting taught thoroughly. Engineering course of nine months' duration equivalent to three years of college radio work. All expenses low. Catalog free. School established 1874. Dodge's Institute, Turner St., Valparaiso, Ind.

QUICK WAY to make money in RADIO

Modern receivers are demanding men with modern training for service work. New training method and service equipment offer starts you earning almost at once. Up to \$3 an hour easy in a short time. Write today for FREE book of details. Radio Training Association of America Dept. S.W.C.-611 4525 Ravenswood Ave., Chicago

RADIO ENGINEERING

RCA Institutes offers an intensive course of high standard embracing all phases of Radio. Practical training with modern equipment at New York and Chicago schools. Also specialized courses and Home Study Courses under "No obligation" plan. Catalog, Dept. SW-38.

RCA INSTITUTES, Inc.

75 Varick St., New York. 1154 Merchandise Mart, Chicago
Recognized Standard in Radio Instruction Since 1909

RADIO COURSES

RADIO OPERATING: Prepare for Gov't License Exam. ● RADIO SERVICING: Including Short Wave ● AMATEUR CODE ● New Course in ELECTRONICS: Day and Evening Classes. Booklet Upon Request.

New York YMCA Schools
6 W. 64th Street, New York City

Learn TALKING PICTURE PROJECTION SOUND RECORDING TELEVISION-RADIO



Quality for Good Jobs Learn in Los Angeles. Practical instruction. Newest equipment. Master training courses. 10,000 graduates. Earn room and board while learning. Coach R. R. free allowed to 1. A. Send coupon for Catalog.

NATIONAL SCHOOLS - LOS ANGELES

Dept. SWC-11, 4000 S. Figueroa St.

NAME.....AGE.....
ADDRESS.....
CITY.....STATE.....

A De-Luxe Ultra High Frequency Receiver

(Continued from page 406)

5Z4, rectifier.

As can be seen in the photograph, it is constructed in a neatly finished cabinet and has an attractive professional appearance.

The above information is furnished by courtesy of the Hallicrafters, manufacturers of the receiver.

New Code-Teaching Machine Works from Lamp Socket

(Continued from page 406)

plainly visible; thus a student can see exactly how he makes the signal.

Again comparing sending to handwriting, if one was to learn to read only perfectly-formed letters he would experience considerable difficulty in reading the average handwriting. Then, should one learn the code from perfectly-formed characters, or from the sending of only one operator, he would experience the same difficulty in reading other senders. The new system of teaching offers a perfect solution to this problem. All those using this instrument are requested to submit to the sponsors "recorded tapes" showing their sending. If the sending is not correct, they are told what their faults are and how to overcome them. After a student passes a satisfactory examination, showing that he can send good readable signals, not necessarily fine signals, but those up to teleplex standards, he is given the names of other students who have passed a similar test, with whom he may exchange tapes. In this way the student gets an unlimited amount of practice and also has the enormous advantage of practicing in reading a large variety of sending. This gives the student practice in what amounts to actual working conditions.

One of the greatest advantages of this code-teaching instrument is the fact that it is so flexible that it holds the student's interest. When he get tired of receiving, he can amuse himself at sending! He can make tests from time to time, and by keeping a record of the results, determine exactly what progress he is making. There is no guess-work.

The student is furnished a complete course of instructions, designed to advance him step by step. For the beginner, the alphabet is divided into three sections. The first instruction tape contains only the letters E T A N I S H M O. These are the most simple letters and can be easily and quickly learned. These letters are then used to form words. The student practices with these letters until he can read all of the words at 10 to 12 WPM. While he actually could not read any of the signals, or at least a very few on the air, he is convinced that he can learn the code. He can already send and receive. It braces up his courage. On the other hand if he should attempt to learn all of the letters together, he would very likely become discouraged. With the few letters he becomes "Code-minded." He knows what it is all about. Then when he goes to the second and third groups, he has had some experience and the more difficult characters come more easily.

In the beginners tapes the characters are spaced very far apart, thus giving the student plenty of time to concentrate upon each character and determine what it is, before the next letter is made. As his receiving speed increases the characters are formed closer together, until in the final advanced tapes, regular standard spacing is used.

It should be noted that this apparatus does not send mechanical signals. It is an instrument to mechanically reproduce ac-

Train at Home Under FACTORY ENGINEERS for GOOD PAY Spare-Time and Full-Time Jobs in RADIO



LEARN TO EARN UP TO \$75 A WEEK

If you're dissatisfied with small pay—and an uncertain future, get my big FREE book, "RADIO'S FUTURE AND YOUR OPPORTUNITY." This book tells how you can learn at home under the supervision of factory engineers to make more money almost at once in Radio—how to make Radio your life's work, or how to earn \$5 to \$20 a week extra in your spare time.

MORE OPPORTUNITIES THAN EVER BEFORE

1935 was Radio's biggest year. Over 5 million new sets sold. Over 30 million dollars paid for service alone. Where only a few hundred men were employed a short time ago, thousands are employed today. And where a hundred jobs paid up to \$75 a week—there are thousands of such jobs today—many paying even more. New full time jobs and spare time jobs are being created all the time.

"SHOP TRAINING" FOR THE HOME

R-T-I Training is different. It comes to you right out of the factories where Radio sets and other vacuum-tube devices are made. It was planned and prepared and is supervised by radio engineers IN these factories—by men appointed for the purpose. R-T-I will train you as the Radio Industry wants you trained.



BIG MONEY IN AUTO AND POLICE RADIO WORK

W. H. Carr, 402 N. 16th St., Kansas City, Kans. R-T-I student has charge of 35 radio equipped Police cars. He gets \$230.00 a month and free auto, gas, oil, etc. He says: "If I had not taken your course I would not be able to hold this job."



MAKES \$600 IN ONE MONTH

Herbert B. Thomson, Gorman, Texas, started making money with 12 lessons finished. He says: "Because of my R-T-I Training I made \$150 in September and over \$600 in October, 1935. It pays to be R-T-I Trained."

TELEVISION, PHOTO ELECTRIC CELLS, PUBLIC ADDRESS SYSTEMS INCLUDED

Radio service work is plentiful but it's only the starting point in R-T-I Training. From there you'll go through the whole field of Radio and Electronics. You will learn about every new development, including Television so you'll be ready when Television breaks.

4 WORKING OUTFITS FURNISHED

Start almost at once doing part time radio work. I furnish 4 outfits of apparatus that you build into test equipment with which you can do actual jobs and earn extra money. My training pays its own way, and you get your money back if not satisfied. Age or lack of experience is no handicap.

FREE BOOK

Find out why R-T-I Trained men get "Quick Results" and "Big Results." Send for "Radio's Future and Your Opportunity" today. It tells about Radio's amazing opportunities. It describes my approved training—what R-T-I students are doing and making. It gives the names of 50 firms who endorse and recommend R-T-I. It's FREE.

Ray D. Smith
President Radio and Television Institute
Dept. 218
2150 Lawrence Ave., Chicago

MAIL COUPON FOR FREE BOOK

RAY D. SMITH, President,
Radio and Television Institute (R-T-I)
2150 Lawrence Ave., Dept. 218
Chicago, Ill.

Without obligating me, send FREE Book about spare-time and full-time Radio opportunities and how I can train for them at home.

Name.....
Address.....
City.....State.....

Please mention SHORT WAVE CRAFT when writing advertisers

"Air-Testing" the NC-100

(Continued from page 407)

too, when the receiver is used in the broadcast band, the tone quality is so very good that it has caused many of our amateur friends to comment upon it. It is, to state the case mildly, considerably better than the tone quality produced by the average, high-priced receiver designed for home broadcast reception.

"DX" With Real Quality

Another very surprising feature of this remarkable receiver is its ability to bring in the Foreign broadcast programs with very much the same degree of satisfaction as the regular local broadcasts. When we say local, we mean broadcasting stations throughout the United States and Canada because, at night, almost any station, anywhere in the country can be heard. During the daylight hours when the reception of programs on the regular broadcast band was limited to a few hundred miles if reasonable freedom from background noise was desired, we have listened to complete programs from the French, English and German S-W stations.

Fading Negligible

One distinct feature, noted in listening to stations a long distance away, was the remarkable rapidity with which the automatic volume control functions. By throwing the switch from automatic volume control to manual volume control it was possible to notice the vast difference in fading between one position and the other. The automatic volume control action is so good that very little fading effect is noted even when the actual fading condition is very severe with the switch in the manual control position.

Another combination of units, which has proved of inestimable value is the Electron Tuning Eye and the Radio Frequency Gain Control. Of course, when the Electron Eye is employed, there is very little possibility of the receiver reproducing distortion, resulting from the tuning mechanism being in a position that is off resonance. The simplicity with which this eye prevents this condition, makes the receiver, even though designed for communication purposes, ideal for use by the entire family.

"R-Meter" for Hams

When this eye is used in combination with the Radio Frequency Gain Control it is possible to draw up a comprehensive group of figures which will indicate to the amateur at the opposite end of the line just how strong his carrier is at our receiver. As the carrier strength increases the Radio Frequency Gain Control can be retarded until the Electron Eye assumes a definite pre-determined position. The further back we can set this gain control, the stronger is the received carrier.

Another combination which has proved to be very desirable is the Radio Frequency Gain Control and the Audio Volume Control. By a suitable adjustment of both these controls it is possible to bring in a desired program or telegraph signal at any desired level and at the same time reduce interference to a minimum.

Crystal Filter Aids Selectivity and Holds Tone Quality

And speaking of interference brings us to the Crystal Filter Circuit which is found in the NC-100X and the NC-100XS receivers. So much has been said about Crystal Filter Circuits since they were first introduced in this country by Doctor James Robinson, famous for his Stenode inventions, and later by James Lamb who popularized the use of Crystal Filters in receivers for communication purpose, that little need be said regarding the application of these filters to these new National Receivers. There is, however, one exception to the generally accepted opinion regarding the utility of Filter circuits of this nature. Several articles have appeared and there is much conversation among amateurs over the air, regarding the manner in which tone quality would be negatively affected, if Crystal Circuits were to be incorporated in receivers designed for the reception of music and speech rather than for reception of continuous wave telegraphy. It has been assumed, up to now, that the introduction of a Crystal Circuit would cause so much

POWERTONE 5-BAND 4-TUBE A.C. D.C. COMMUNICATIONS RECEIVER

- ★ Band Spread Tuning
- ★ 15-550 Meter Tuning Range
- ★ New Metal Tubes Used
- ★ Built-in Power Pack
- ★ 5 Band Wave Switch
- ★ A.C. D.C. Operation
- ★ Built-in Dynamic
- ★ Tone Control & Switch

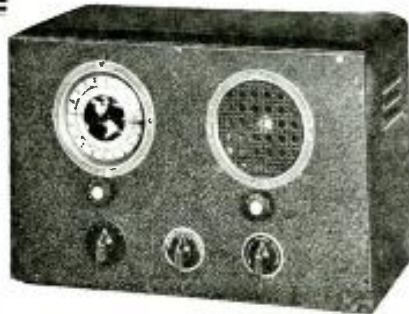

Complete kit of parts, including pictorial and schematic diagrams, unwired, less tubes and cabinet \$10.50
 Wiring and Testing, extra 2.50
 4 Matched Sylvania Tubes 2.25
 All Metal Crystal Cabinet 2.25

Some of the features found in this masterpiece of engineering are: Band Spread Tuning; Full Sized 1" airplane type dial; Adaptability to operate on either A.C. or D.C.; Elimination of plug-in coils by means of a 5-band wave switch; Built-in Dynamic Speaker; Use of the new Metal Tubes; and others too numerous to mention.

The circuit makes use of two of the new metal tubes. They are two 6X7's which are used to provide maximum selectivity and sensitivity. A 43 power pentode used to drive the dynamic speaker, and a 25Z5 tube used for rectification purposes.

Band Spread Tuning

Band Spread tuning of all signals is made possible by use of a large sized 1" airplane dial. The signal received is spread across the whole dial, thus aiding materially in tuning stations and provide better sensitivity.



"Buddy-2" 2-Tube A.C. - D.C. Receiver.

Operates on either A.C. or D.C. Makes use of 1-6J7 metal tube and 1-12A7 as a combined rectifier and pentode output tube. Furnish with four plug-in coils which tune from 15 to 200 meters.

Additional coils to extend the range down to 9½ and up to 2000 meters are available. Complete kit of parts including pictorial and schematic wiring diagrams, unwired, less tubes, cabinet and additional coils \$4.50
 Wiring and testing, extra 1.25
 2 Matched Sylvania tubes 1.50
 Crystallized metal cabinet .95
 9½-15. and 200 to 2000 meter coils 1.75

Powertone 5 Meter Portable 3-Tube Transceiver

It is a powerful low current consuming model featuring a unity coupled circuit. Once you have established contact there is no trouble in maintaining contact when switching to sending and receiving positions. Makes use of 1-30 and 2 type 19 tubes.

Complete kit of parts including pictorial and wiring diagrams, unwired, less tubes, cabinet and microphone \$9.50
 Set of 3 matched Sylvania Tubes 1.48
 Portable All Metal Cabinet 1.95
 Wiring and Testing 2.50
 Matched Hand Microphone 1.75



TRY-MO RADIO CO., Inc. 85 Cortlandt St., N. Y. C.
POWERTONE ELEC. CO., Inc. 179 Greenwich St., N. Y. C.

SPECIAL ★

America's Outstanding Microphone Value! Public Address and Sound Equipment men—here is what you get in this amazing offer!

1 Lifetime No. 6 D.B. Mike. List \$8.00 Sold separately at \$2.95
 \$3.75 Sold separately at \$1.75
 1 Lifetime Shielded Matching Transformer \$2.75 Sold separately at \$1.45
 1 Lifetime # Foot 3 conductor shielded cable sold separately at \$1.45

LIFETIME Model No. 6 Double button microphone is ruggedly constructed—finished bright aluminum polish. Is 1½" diameter and 1½" thick overall. Has gold sputter duraluminum stretch diaphragm, gold contact buttons, finest carbon granules and has frequency response between 40 and 3500 c.p.s. Order direct from manufacturer and save MONEY.

THE LIFETIME CORPORATION
 1008 Madison Ave., Toledo, Ohio
 Manufacturers: Microphones, Carbon Condensers, Crystal, Velocity and Dynamic Aluminum Trumpets, Electro Dynamic Units, Batteries, complete P.A. and Sound equipment. Write for catalog.

OUTFIT FOR ONLY \$4.95

tual hand signals, say its sponsors. The automatic sender has always had the advantage of sending at a steady rate of speed, which is best for teaching purposes. An experienced operator cannot send at a slow rate of speed and maintain a steady speed. The disadvantage of automatic senders has been that they make mechanical signals; that is, the signals are made with a perforating machine that spaces the signals mechanically correct. As no operator can send mechanically correct signals, it is vital that the student get practice in receiving actual signals, the very kind that he will have to read. The new code teaching device illustrated combines the advantage of the automatic transmitter and hand or "bug" sending. It maintains the steady speed of the automatic sender, but sends actual signals. Furthermore, the machine will send at a much higher rate of speed than an operator can maintain. The best operator cannot maintain much better than an average of 35WPM. On the other hand a good operator can read the signals at 50 WPM, after he has had practice at that speed. As a matter of fact most any operator can read signals much faster than he can write them down. The reason for that is that most operators have never had the necessary practice in receiving high speed signals that would enable them to become very fast and accurate in writing with either a pencil or the "mill." This machine will give that practice under perfect conditions as the speed can be increased as the student's ability increases.

This article has been prepared from data supplied by courtesy of Teleplex Co.

XL VARIO DENSER

The "Original" trimmer condenser—Holds its capacity under all conditions—wide range—mica dielectric—air tight moulded case—small size—Available in wide variety of capacities.

Mod. N \$1.00 ea.
 Mod. G \$1.50 ea.

The XL PUSH POST is the binding post par excellence, and our non-corroding navy type push post was created for use in the all weather portable radio sets of the U.S.N. war department. These binding posts passed the severest test of a 240 hour immersion in salt solution. Non-Corroding—Navy Type—Bak. Top 28c ea. Type B (Aluminum Base, Bakelite Insulated Top) 15c Type M (All Aluminum Body) at 10c each.

Buy the best—it's the cheapest in the long run.

X. L. RADIO LABORATORIES
 1224 Belmont Ave. Dept. S. W. 11, Chicago, Ill.

PATENTS — TRADE MARKS

All inventions submitted held confidential and given personal attention by members of the firm.

Form "Evidence of Conception" and instructions

"How to Establish Your Rights"—Free

LANCASTER, ALLWINE & ROMMEL
 PATENT LAW OFFICES
 475 Bowen Bldg. Washington, D. C.

The December issue will be chock full of "HOT" articles for the S-W "FAN." Don't MISS That Number!

damage to the tone quality as to make its use ruinous. This is far from being true.

While, in the Stenode receivers, introduced a few years ago, special audio amplifiers, having a rising amplification characteristic, were employed the amplifier now in the NC-100 is essentially flat. Even so, we have been able to listen to broadcast programs, at night, over considerable distances, with a very good quality of reproduction by utilizing the Crystal Circuit to cut down various types of background noise. While it is true that the same program would cover a wider audio range without the Crystal, the fact remains that the cutting off of some of the high frequencies, resulting from the introduction of the crystal, would cut out so much of the interference as to make the program entertaining even though it was recognized that the full tone range was not there.

The background noise, without the crystal, reduced the actual entertainment value of such a program to a very low order.

In connection with amateur radio telephone communication, we have found that the use of the Crystal Circuit has enabled us to hear conversations with greater clarity when the same station could not be picked up with any degree of intelligibility when the Crystal Filter Circuit was cut out.

(Mr. Ruth has purposely avoided the mention of the great band-spread found in these new receivers, because that feature was covered in the descriptive article which appeared in the September issue of Short Wave Craft.—Editor.)

Presenting Model T-37 A SIGNAL GENERATOR that "Does Everything" only \$12⁴⁰



Released by SUPERIOR INSTRUMENT CO., for limited time only.

- 110 Volts A.C. or D.C. 100 kc. 20 megacycles all on fundamentals.
- Dial is direct reading in frequencies.
- R.F. output may be taken from a high impedance or a low impedance post, in with attention present for either.
- Separate audio output at 2 amplitude levels, so that tone may be used for checking public address systems, audio amplifiers in receivers, and speech amplifiers in transmitters.
- Two extra posts on front panel enable leakage tests. Condensers may be checked for leakage, so may tubes, and other normally high resistance currents, otherwise difficult to test.

Model T-37 All-Wave Signal Generator, wired, in shielded cabinet with carrying handle and calibrated, tested; complete with 3 tubes, instructions \$12⁴⁰ (shipping weight 7 lbs.)..

Superior Instruments Co., 139 Cedar Street, New York, N. Y., Dept. SW-11

New 18-Tube Receiver Has Range 4.5 to 2400 Meters

(Continued from page 408)

vided in the "Dim-a-Lite." This feature has been extended to include three pilot lights, which give a display of alternating colors. Exact tuning is easily accomplished, and when the Silencer Push Button is released, the program will be found to be perfectly tuned in.

The world's most powerful and reliable stations are clearly pointed out in colors on this beautiful dial, as a further means of increasing the user's delight and enjoyment. All "cleared channels" are indicated by Red triangles which indicate not only the position of the station, but its approximate power. On these channels, clear reception can always be expected without interference from other stations. On other partially cleared channels, where interference is very rarely encountered, the position and approximate power of the stations are indicated by means of Green triangles. Some channels are shared by many stations and, of those, reception is very poor, unless one of the stations is actually located within a few miles of the receiving set. These channels are indicated by means of short wavy lines and are marked "Local Stations Only."

A similar very simple and useful calibration is shown in the lower half of the dial as an aid in tuning the world's most powerful short-wave stations. The expression "Pre-logged" may very aptly be applied to these dials, inasmuch as all useful stations are indicated just as if the owner had marked the dial after many hours of use.

It is impossible to enumerate all of the 85 features incorporated in this radio. Many of them are outstanding and deserve special attention. The tone quality is greatly superior. This is due not only to the dual channel resistance coupled audio amplifier but is also due, in a great measure, to the superb output stage. Four of the new Triple-Twin tubes are used, in push-pull parallel power amplification, which really converts your 18-tube receiver into 22-tube performance. This powerful audio system feeds a positively driven speaker, which is forced by the sheer weight of the extra power, to follow the music without any freedom of its own, which might cause distortion and unpleasant noises.

The chassis is very handsomely con-

structed on an extremely strong base. Many stations that are very rarely pulled in may be enjoyed with full loud-speaker volume, with a noticeable lack of fading and with an unusual reliability of repetition at later dates.

This article has been prepared from data supplied by courtesy of Midwest Radio Corp.

"NET" ACTIVITY ON FIVE METERS

"W—" control station for THE INTER-STATE FIVE METER NET calling group "—" to order for an official meeting,—the roll is called,—notes of interest are forwarded—new net activity is discussed—DX reports are issued, received by special relay chain from outlying net members,—messages received from the lower frequencies, members of the net, etc., are forwarded or received for forwarding,—scheduled DX capabilities tests are conducted among members,—technical dope and notes of interest are exchanged,—swaps are conducted,—final greetings are issued and thus ends another meeting—fast moving and interesting—of THE INTERSTATE FIVE METER NET.

Any amateur operating in the five-meter band, in spite of power, location handicap, etc., if interested is most certainly welcome to join the "net."

There are no obligations, dues or requirements necessary outside of keeping reliable "scheds."

Certificates, radiogram blanks, letter-heads, etc., are issued to all members writing the chief control station—W2HUT, 478 Dean St., Brooklyn, N. Y.

The Editors Want

articles describing in detail Television receivers on which short-wave experimenters may pick up the television images being broadcast by the RCA Station, atop the Empire State Bldg., in New York City, on about 6 meters, and also those being broadcast from the Don Lee Station on a similar wavelength in California. All articles accepted and published will be paid for at regular space rates. Send outline of article and what photos or diagrams available to: The Editor, Short Wave Craft, 99 Hudson St., New York, N. Y.

THE WORLD FAMOUS D-104 CRYSTAL MICROPHONE



Clear Clean Tone

ASTATIC

CAN'T BE BEAT for "SPEECH RANGE" EFFECTIVENESS

Amateurs the world over—under every broadcast condition—have proved the higher output in the "speech range" of the Astatic D-104. Excellent frequency response; non-microphonic; built rugged for long service and rough handling; fully guaranteed.

SEE YOUR JOBBER

List Price D-104 as shown.....	\$22.50
With handle (D-104H).....	\$25.00
With switch in handle (D-104HS).....	\$25.50
With relay switch (D-104RS).....	\$27.50

Licensed under Brush Development Company Patents

ASTATIC MICROPHONE LABORATORY, INC., DEPT. S-11 YOUNGSTOWN, O., U. S. A.

Pioneer Manufacturers of Quality Crystal Devices

Low Wholesale Prices BIG FREE CATALOG



Over 10,000 items in this big catalog including radio receivers, nationally known radio parts and broadcasting equipment at lowest wholesale prices. A catalog of great value to dealers and servicemen. Write for your FREE copy of this big catalog today.

BURSTEIN-APPLEBEE CO.
1012-14 McGee St., Kansas City, Mo.

Please mention SHORT WAVE CRAFT when writing advertisers

AMPERITE presents..

The NEW RBm VELOCITIES



Distinguished in Quality, Design, and Construction

Featuring..

1. Output increased 6 DB.
2. Triple shielded—against all RF or magnetic fields, entirely eliminating hum pickup.
3. Eliminates feedback troubles.
4. Excellent for close talking and distant pick-up.
5. Acoustically designed to eliminate any possibility of cavity resonance.

Models RBHn (High Impedance): RBMn (200 ohms) \$42.00 List

NEW! Models RBSn. RSHn—Excellent All-around Microphones for Speech and Music. Slightly lower output and frequency range than above. Appearance same as above. \$32.00 List

NOW! A specially designed microphone built to Amperite standards. can be used for both speech and music. No peaks. Flat response. Triple shielded. Shock absorber. Swivel bracket.

Models RAL (200 ohms): RAH (2000 ohms) \$22.00 List

FREE! TO DEALERS AND SERVICE MEN: A striking window decal advertising your SOUND SERVICE, and displaying the new Amperite Velocity. Write for it now!

AMPERITE Velocity MICROPHONE

WORLD WIDE RADIO ALL WAVE - RADIO ONE TUBE KIT ONLY \$1.25

Haven't you always wanted a Real, Powerful Radio Receiver all your own? A Short and Lobe Wave set that will actually bring in many foreign stations from all parts of the World, police calls, airplanes, amateurs, etc., as well as your local stations. ACE Radios give **GUARANTEED RESULTS!** Thousands now in use. Amazing performance!

NOW, the world famous ACE Construction Kits are priced so low that anyone can afford one! For only \$1.25, we send you, postpaid, every part needed to build a powerful one tube receiver with heavy, attractive metal chassis. Not a feeble crystal set! Works on two inexpensive dry batteries. Later, you can change your set into the Two Tube Battery or All Electric set at special low cost! You get a valuable radio education by wiring it yourself from our clear diagrams. It's easy for even a child! Just a few simple connections. Wavelengths range 15 to 600 meters.

FOR MORE POWER AND VOLUME \$2.00 BUY THE TWO TUBE KIT

ALL ELECTRIC TWO TUBE RECEIVER \$3.00

No batteries needed. Just plug into any 105 to 125 volt AC or DC house line. Complete Kit.

Tube—75c each. Double head-phones—\$1.15. Any kit laboratory wired and tested—75c extra. **REMEMBER!**—We pay the postage! Save you 15c to 50c or more.

ORDER NOW! NOT A TOY OR AN ATTACHMENT!! ACE RADIO LABORATORIES

70 Barclay St., Dept. C-11 New York City

NATIONAL NC-100

SUPER RECEIVER FOR THE SHORT WAVE LISTENER OR THE NC-100-X WITH CRYSTAL FILTER FOR "HAM" BRASS POUNDERS BOTH MODELS CAN BE SUPPLIED FROM STOCK

Write for Free Catalog

CAMERADIO

601-3 GRANT ST., PITTSBURGH, PA. 30 TWELFTH ST. WHEELING, W.VA. Established 1919

Let's "Listen In" With Joe Miller

(Continued from page 412)

hurry! EHZ has been verified in less than a month, thru the above QRA, and be sure that you include either a reply coupon or an unused Spanish 30 centavo stamp, as this radio station insists upon return postage being enclosed, or else—!

Siam

Phra Aram Ronajit, the genial Supt. Engineer of the Siamese commercial phone circuits, sends the following skeds for tests of his famous SW DX stations:

HSP, 16.92 meters or 17.75 mc., tests with Tokio at 11 p.m. Sundays and 4 a.m. Mondays, again at 11 p.m. Wednesdays and 4 a.m. Thursdays, and after the last two tests also contacts Berlin. HSJ, whose wave is given as 37.6 meters or about 7.97 mc., tests with Saigon "fortnightly," or every 2nd week, on Mondays at 10:30 p.m. Your guess is as good as mine as to which is the second week. hi! Phra Aram adds "but these times are subject to alteration." He also requests reports, which seems to be a vain hope with these skeds in effect.

ASIATIC U.S.S.R.

RKI, Moscow, on 15.08 mc. calls Alma Ata, RWJ, 12.19 mc., often at 6 a.m. RWJ, an Asiatic, has a fairly good signal. RKI is mostly heard working RIM on 15.25 mc. at Tashkent, Russian Turkestan, around 6-7 a.m. ROU, on 14.79 mc. at Omsk, Siberia, also has been heard with RKI between 6-7:30 a.m., and once was heard phoning RKK, Moscow, on 12.27 mc., at 3 a.m., with a very good sig. So if you hear RKI talking, by tuning to any of the above frequencies you may log one of these USSR Asiatics.

All of these Russian phones can be verified by writing to: Comité de Radiodiffusion et Radiofication, Petrovka 12, Moscow, USSR. Do not address ur reports to "Russia," or your letters will never reach their destination. In a veri of RKK, RIM and ROU, M. Skobelev requests reports on the new Moscow station RAN, on 9.52 mc., which BCs an English program at 7 p.m.

ERITREA

Remember IDU, in Asmara, Eritrea, which made such a noise last winter? Well, the war's over, so Rome is now issuing verifications of all IDU reports, so if you are one of the lucky OMs to have written down a log of IDU, just send it in to the following QRA, and enclose a reply coupon, and we are sure you'll be the proud recipient of a bonafide veri of Eritrea, an Ace African and a new country! Rome verified our report of last November!

The QRA is: Ministero della Marina, Direzione Centro R.T. Autonomo R. Marina, Rome, Italy, and the reply takes about two months.

In connection with IDU, we've a story to relate:

Having written several reports of IDU, with no results, "ye Ed" decided that "the time had come," and so a letter was sent registered, return receipt, air mail, and addressed to His Honor, Premier Benito Mussolini! After a two months wait, a letter was received from the Italian Consulate in N. Y. City advising us that we would shortly receive a reply from Rome. Two weeks later a veri was in our mail box, from the Head of the Cabinet, Eduardo Somigli, formally confirming reception of IDU. Success!!

Java

A new Javanese SW "BC" station was heard at 6:30 a.m. Sunday, on about 15.13 mc., relaying the same program as PLP. Signal was only an R5, and can be easily identified by the same "bumpy" signal as that of PLP. PMA on 19.35 mc. has been putting in an unbelievably strong and steady signal into the U.S.A. lately, being heard in the later hours of the morning, from about 8-11 a.m. with varied and excellent musical programs, novel in their

NEONTRON

Guaranteed RADIO TUBES at New LOW PRICES!

Complete Stock Ready for Immediate Shipment
Order from this page—Remit 20% with order, balance C. O. D. All prices are F. O. B. FACTORY, Newark. Shipments go forward express or parcel post. No order for less than \$3.00 accepted.

Guaranteed for 6 Months Licensed by R.C.A.

METAL TUBES

Type	Net Price	Type	Net Price	Type	Net Price	Type	Net Price
6K7	\$0.61	6F5	\$0.49	1E5	\$0.78	5Y3	\$0.49
6A8	.73	25Z5-MG	.61	1E7	.78	6D8	.49
6J7	.61	43-MG	.61	1F5	1.05	6Q7	.49
6C5	.49	38MG	.69	1H4	.54	6R7	.49
6H6	.49	75MG	.69	1H6	.78	6S7	.49
5Z4	.61	1C7	.81	1J6	.66	6Q6	.49
6F6	.61	1D5	.81	5V4	.85		
6L7	.73	1D7	.78	5X4	.61		

REGULAR TUBES

Type	Net Price	Type	Net Price	Type	Net Price
00A	\$0.21	46	\$.32	99X	\$.39
01A	.21	47	.32	99 Std.	.39
1V	.45	48	.79	WD11	.55
10	.79	49	.39	WD12	.55
12A	.26	50	.55	1A4	.63
19	.29	53	.44	1A6	.44
20	.21	55	.32	1C6	.44
22	.44	56	.24	2A3	.42
24A	.29	57	.32	2A5	.32
26	.21	58	.32	2A6	.32
27	.23	59	.44	2B6	1.13
30	.26	71A	.26	6B5	.90
31	.26	75	.32	2A7	.44
32	.44	76	.26	2B7	.44
33	.33	77	.32	5Z3	.28
34	.44	78	.32	6A4 (1a)	.44
35/51	.29	79	.40	6A6	.44
36	.29	80	.22	6A7	.44
37	.26	81	.55	6B7	.44
38	.29	82	.32	6C6	.32
39/44	.29	83	.32	6D6	.32
40	.21	83V	.52	6F7	.49
41	.35	84	.44	12A5	.69
42	.33	85	.32	12A7	.90
43	.33	89	.32	12Z3	.29
45	.24	99V	.39	25Z5	.33
				PZM	.49

MAJESTIC TYPE TUBES

Type	Net Price	Type	Net Price	Type	Net Price	Type	Net Price
2A7S	\$0.83	6C7	\$0.83	6Z5	\$0.79	56S	\$0.55
2B7S	.83	6D7	.69	24S	.49	57S	.69
2S-4S	1.19	75S	.69	25-25S	1.22	58S	.69
2Z2-G84	.83	6F7S	.79	27S	.32	6E7	.69
6A7S	.83	6V5	.79	35S-51S	.55	85S	.69
6B7S	.83	6Z4	.49	55S	.69		

SPECIAL PURPOSE TUBES

Type	Description	Net Price	Type	Description	Net Price
182B	Sparton type	\$.44	586	Sparton type	\$.79
183	Sparton type	.44	401	Kellog type	.90
484	Sparton type	.44	403	Kellogg type	1.13
485	Sparton type	.44	686	Sparton type	.68
Type	Description	Net Price			
BH	Raytheon type 125 mil rec.	\$.13			
6E5	Cathode Eye	.48			
216B	Half wave rectifier	.90			
Neon	Tuning Lamps (single contact)	.85			
Neon	Tuning Lamps (double contact)	.59			
866	Heavy Duty	.90			
866A	Extra Heavy Duty	1.50			

CHARGER BULBS

Type	Net Price
6, 10 amp trickle charger bulbs (tungar type)	\$.65
2 amp charger bulb with wire (tungar type)	1.80
2 amp charger bulb without wire (tungar type)	1.80
5 and 6 amp charger bulbs (tungar type)	3.75
15 amp charger bulbs (tungar type)	7.50

TELEVISION TUBES, PHOTO ELECTRIC CELLS,

1" sq. cathode television tube	\$2.85
1 1/2" sq. cathode television tube	3.85
1" sq. cathode reflectron window type 50-60 mils	2.85
Cold cathode crater tube crater size .010 to .250	5.75
Photo electric cells (potassium type) 2 1/2" length overall	1.75
Photo electric cells (potassium type) 1" length overall	5.90
Photo electric cells (caesium type) 3 1/2" length overall	3.90
Photo electric cells (caesium type) 1 1/2" length overall	5.90
Photo electric cells (caesium type) 868 type	3.90
Supersensitive Relays for above cells	2.95

MAKERS OF NEONTRON TUBES
ARCO TUBE COMPANY
227 Central Avenue Newark, N. J.

Please mention SHORT WAVE CRAFT when writing advertisers

melange of Oriental and Occidental selections.

Senor Enrique Diaz Exposito, of the Radio Club Tenerife, Canary Islands, in a recent letter gave the latest skeds for EA8AB. This nice DX catch can now be heard as follows:

Mons.-Weds.-Fris. and Sats.—3:15 to 4:15 p.m., on 7010 Kc., not 7210. This station sends a vy FB QSL, and is best heard in midwinter.

SOUTH AFRICA

ZSS, Klipheuvell, South Africa, on 18.89 mc., is another Ace African that every DXer would be proud to verify. This station phones GAU, 1862 mc. nearly every day around 6:30-7 a.m., so tune for GAU every morning, and if GAU is heard, try for ZSS. ZSS has a peculiar carrier wave, quite distinctive, as it slowly "waves" about once a second, so that you can't miss it if it's on! The carrier wave readily identifies ZSS. Reports should be addressed to: Overseas Communications of South Africa Ltd., P.O. Box 962, Cape-town, Union of South Africa. Be sure to send a reply coupon.

Czecho-Slovakia

Radio Podebrady, Czecho-Slovakia, has been reported by Mr. Pierre Portmann, the 10 HAC DX-er from Woodside, New York. OM Pierre heard this catch on 15.23 mc. from 12:30-1 p.m., and on 11:76 mc., from 1-1:30 p.m. Here's a chance for those DXers who haven't yet heard Czecho-Slovakia to add it to their log of countries heard, and, we hope, verified!

Mr. Russ Ballard of Brooklyn, the proud owner of some very FB QSLs, among them several ZL phones on 75 meters, reports a veri from IDU, with the following valuable data: The Italian stations at Addis Ababa operate on phone and CW on the frequencies given: IUA, 5880; IUB, JUB, 7620; IUC, 11955; IUD, 18270; IUF, 6922; IUG, 15450 Kc.

ITK, 16385 Kc., located at Mogadiscio, Italian Somaliland, which normally telegraphs IBC and IRY at Rome, is now frequently conducting radiophone tests, working either IBC or IRY, so watch for this FB African, as yet unreported by DXers. Will you be the first to log this Ace?

ICK, Tripoli, another hard-to-get African, phones Coltano, and uses either 9460 or 5823 Kc. Rome adds that ICK uses 10235 Kc. to telegraph Rome, daily.

***** Ham Stardust *****

Latest Up-to-date DX results on 20 Meter Phone.

We are still hearing the VK phones regularly, best heard on Sat es Sun, from 5:30-7 a.m., also, tho not so consistent, from 12:30-1:30 a.m. Not as many heard now, as last spring, but new ones are ever "popping up"! "Ye Ed" has passed the 100 mark in VK phones heard in '36, some weeks ago.

Asiaties are beginning to come through on "20," in early a.m.s from about 5:45-6:15 a.m. KA1AK is consistent on 14170, es watch for PK1MX, at Batavia, Java, on 14090, with 45 watts. Also look for PK1MV near 14100, heard working VK6MW, near 14050, at 6 a.m., both R6-7 here. Also heard was CP1AA, La Paz, Bolivia, heard at 12:20 a.m. on low frequency end of 20 meter band. Giving accurate frequency difficult, due to damp drift on my National SW58.

PK1MX sends swell green QSL, with red letters. ZS1C sends a real FB 3 page letter, a fine amateur! Sez that ZE1JR's license was suspended 'cause he Beast musical programs, "stfictly forbidden in So. Af." ZE1JR got over 500 reports on this Xmission alone, no wonder he failed to QSL to so many reports! Thru ZS1C we find that 1JR is an American! ZS1C adds that "my SW (Sweet Woman) thinks your QSL the prettiest bit of work she has ever seen in QSLs, MIM!" Truly a grand compliment, Mrs. ZS1C, and we hasten to register our sincere gratitude! Hi!

50 watts is Max. input power allowed down there. ZS1C will be on "10," too,

on 28100 or 28200 Kc., es sez that 10 will be hot this season (probably about Oct., judging from last yr), es he'll be there!—I1KS on 29060 is vy anxious for reports. Heard at midnight on 14350 by Charlie Miller, the w.k. Kaintuck' DXer. VS6AQ, on 14302 uses 60 watts, es shud be heard these a.m.s. LY1J, Lithuania, sends one of finest QSLs ever seen here. VK3EG sends QSL 5x12"! Look for VU7FY, on 14385, also, these a.m.s, he sends a novel card you'll be proud to own! VK2ABD sends striking QSL all blue es silver!

Some of the best QSLs we've ever rec'd have come since July. Here is a list of better ones: TDD, CX1AA, PK1MX, PSH, IDU, LY1J, EA8AO, YSJ, PNI, VS6AQ, CR6AA, I1KS, KA1AK, VQ4CRO, RKK, RIM, ROU, XOJ, VU7FY, JVU, JVG, JVH, JVE, JZC thru Tokio, PRA8, EA1AZ, 2BH, 3DQ, 4BM, VK2ABD, VK2AP, 2UD, 2AS, 2LX, 2IQ, 2HB, 2VA, 2MH, 2UC, VK3MR, 3EG, 3JT, 4JX, 5RT, 5AI, 5JC.

Your comments and criticisms on this article are welcomed. All letters and cards will be answered, if possible. Enclose 3c stamp if answer is expected.

Your letter or card will count as a vote towards the continuance of our "DX page." May we count upon ur vote?

In closing may we wish all of you "DX" friends lots of good luck in your DX, for the fall season, ever one of the best for real DX!

The reports given above are based on actual "listening in" tests at Brooklyn, N.Y. Listeners in others states will have to remember to make allowance for the change in time between E.S.T. and their local zone. Also listening conditions may be better, or worse, in other zones for certain European stations. Reports from Central and Western U.S. listeners as to how they find these "Eastern" reports will be highly appreciated.

Radio short-hand: FB—fine business; es—and; vy—very; CW—code; QSL—Verification Card; mc—megacycle; DX—distance; Sked—Schedule; dly—daily.

VALUABLE DATA IN BACK NUMBERS!

Many short-wave set-builders frequently need constructional data on certain transmitters or receivers as well as converters and other allied apparatus.

Recently many inquiries have been received asking for data on "1-meter" sets, for example. The January, 1936 issue contains a very good article describing how to build and operate a transmitter and a receiver of modern type, tuning over a range of from 1/2 to 1 meter.

This shows how important it is to retain all back numbers of this magazine, as they may prove extremely valuable at any moment. Back numbers are available from the Subscription Dept.

Substantial binders are available for preserving these back numbers.

Audio Oscillator and Amplifier

(Continued from page 411)

connect the wire leading from the audio transformer primary to the 12-A-7 plate. As an oscillator, the plate lead should be connected to either the "Plate" or "B-plus" terminal of the audio transformer; one terminal will give much better results than the other. Connect a speaker to posts 1 and 2, and a key to posts 3 and 4. As an amplifier, connect the speaker to posts 1 and 4.

The output of the oscillator is of sufficient volume to cover a large room, making it ideal for use in teaching code to a large group.

Its output as an amplifier is, of course, dependent upon the input signal. The maximum volume is about right for an average size room. When fed from a crystal set, good loud-speaker reception may be had from high-powered stations up to over a hundred miles distance.—Carl C. Drumeller, W9EHC.

BRUSH Spherical Microphone



For remote pickup, "P.A.," commercial interstation and amateur use. Low in price... but built to Brush's traditionally high mechanical and electrical standards. Wide frequency response. Non-directional. No diaphragms. No distortion from close speaking. Trouble-free operation. No button current and no input transformer to cause hum. Beautifully finished in dull chromium. Size only 2 1/4 inches in diameter. Weight 5 oz. Output level minus 66 D.B. Locking type plug and socket connector for either suspension or stand mounting at no extra cost. Full details, Data Sheet No. 13. Free. Send for one.

BRUSH Lapel Microphone



For after dinner and convention speakers, lecturers, etc. Gives great mobility. The smallest, lightest microphone on the market. Size 1 1/2 x 1 1/4 x 3/8. Weight with coat attachment less than 1 oz. Special internal construction and rubber jacketed outer case insure quiet operation. No interference from breathing noises, etc. Typical Brush sound cell response and trouble-free operation. Details on request.

BRUSH DEVELOPMENT COMPANY
1687 E. 40th St. CLEVELAND, O.
MICROPHONES • MARK STANDBY • TWEETERS • HEAD PHONES • LOUD SPEAKERS

RADIOS SAVE UP TO 50%
ALL NEW 1937 MODELS

DEAL DIRECT—FACTORY PRICES! Iron-Clad Guarantee Written
A penny post card brings you our new, full-color 16-page BARGAIN CATALOG free. Many models to choose from: 4 to 19 tubes, AC/DC, All-Wave and new Farm sets that substitute like city radio! Send post card or coupon below for full details of 30-day no-risk trial and Accut User preparation. Write now!

30-DAY NO-RISK TRIAL! \$6.98 MAIL COUPON Free Catalog

GOLDENTONE RADIO CO., DEPT. C, DEARBORN, MICH.
Without obligation, send me new 1937 Catalog and 30-day trial plan.
Name.....
Address.....

Guaranteed 40 Power \$2.48
Long Distance Telescope

New Model! Greater Illumination
Clearly bring distant object close to your eye. Easily see far away subjects magnified with this TESTED Super 40 Power Telescope. Look from your roof or out of your window and far away sights become as clear as if you were on the spot when focused with this trusty WINNERSCOPE. See the moon, stars, ships, sport events, etc. Can also be used as a microscope for scientific observation. Have fun with far away neighbors. Look at what they are doing and phone and tell them about it. They will wonder how you know... makes objects miles as easy appear in front of you. A scientific achievement that defies competition. Durable, brass bound, 4 powerful lenses, 1 foot long closed, about 3 feet open. Made in U. S. A. SPECIAL FREE OFFER. Order at once! We include a genuine pocket telescope that closes to two inches. Fits vest pocket! Great to carry for emergency sights. Send No Money! Pay postman \$2.48, plus postage, or send \$2.48 now and we pay postage. Outside U. S. A. \$2.98 Cash with Order.
J. H. Winn Mfg. Co., Dept. T-911, 124 W. 23 St., New York.

There's More than Efficiency
in TRIMM FEATHER WEIGHTS
We at Trimm take a personal pride in the products we manufacture—this assures you of the finest headset that can be made.
Available from all of the discriminating jobbers
TRIMM RADIO MANUFACTURING CO.
1770 W. Berteau Ave., Chicago, Ill.

Please mention SHORT WAVE CRAFT when writing advertisers

GREAT 10c BOOKS

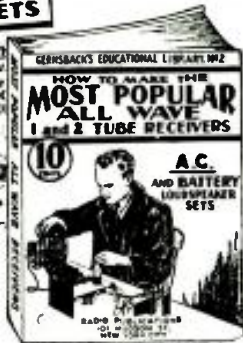
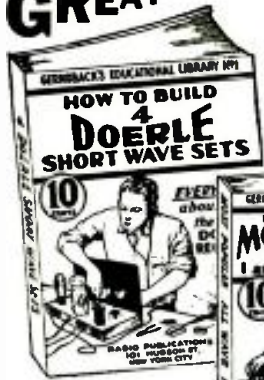

Each book contains 32 pages and numerous illustrations. Over 15,000 words in each book.

HOW TO MAKE FOUR DOERLE SHORT WAVE SETS

LITERALLY thousands of radio fans have built the famous DOERLE Short Wave Radio Receivers. So insistent has been the demand for these receivers, as well as construction details, that this book has been specially published.

Contains EVERYTHING that has ever been printed on these famous receivers. These are the famous sets that appeared in the following issues of SHORT WAVE CRAFT: "A 2-Tube Receiver that Reaches the 12,500 Mile Mark," by Walter C. Doerle (Dec., 1931-Jan., 1932); "A 3-Tube Signal Gripper," by Walter C. Doerle (November 1932); "Doerle 2-Tube" Adapted to A. C. Operation" (July 1933); "The Doerle 3-Tube Signal-Gripper Electrified," (August 1933) and "The Doerle Goes 'Band-Spread'" (May, 1934).

Due to a special arrangement with SHORT WAVE CRAFT, we present a complete 32-page book with stiff covers, printed on an extra heavy grade of paper with numerous illustrations. Nothing has been left out. Not only are all the DOERLE sets in this book, but an excellent power pack if you wish to electrify any of the DOERLE sets, is also described.

HOW TO MAKE THE MOST POPULAR ALL-WAVE 1- and 2-TUBE RECEIVERS

THERE has been a continuous demand right along for a low-priced book for the radio experimenter, radio fan, radio Service Man, etc., who wishes to build 1- and 2-tube all-wave sets powerful enough to operate a loudspeaker.

This book contains a number of excellent sets, some of which have appeared in past issues of RADIO-CRAFT. These sets are not toys but have been carefully engineered. They are not experiments. To mention only a few of the sets the following will give you an idea.

- The Megadyne 1-Tube Pentode Loudspeaker Set, by Hugo Gernsback.
- Electrifying The Megadyne.
- How To Make a 1-Tube Loudspeaker Set, by W. P. Cheney.
- How To Make a Simple 1-Tube All-Wave Electric Set, by F. W. Harris
- How To Build A Four-In-Two All-Wave Electric Set, by J. T. Bernsley, and others.

Not only are all of these sets described in this book, but it contains all of the illustrations, hookups, etc.—each book is thoroughly modern and up-to-date.

Remember, these books sell at the extraordinary low price of ten cents; you can not possibly go wrong in buying them. Despite its low cost, our usual guarantee goes with this book as well!

IF YOU DO NOT THINK THAT THESE BOOKS ARE WORTH THE MONEY ASKED FOR THEM RETURN THEM WITHIN TWENTY-FOUR HOURS AND YOUR MONEY WILL BE INSTANTLY REFUNDED.

There has never been such a wealth of data published in low-priced radio books of this type in the history of the radio publishing business. Take advantage of the special offer we are making and use the coupon below.

RADIO PUBLICATIONS
101 Hudson Street
New York, N. Y.



Send for our FREE circular listing
48 new 10c Publications

GREAT 10c BOOKS



EACH BOOK IS UNIFORM IN SIZE. CONTAINS 32 PAGES AND 15,000 WORDS OF CLEAR LEGIBLE TYPE. LAYS THE GROUND-WORK FOR A COMPLETE STUDY OF RADIO AND ELECTRICITY.

ALL ABOUT AERIALS

In simple, understandable language this book explains the theory underlying the various types of aerials: the inverted "L," the Doublet, the Doublet, etc. It explains how noise-free reception can be obtained, how low-impedance transmission lines work; why transformed lead-ins are used. It gives in detail the construction of aerials suitable for long-wave broadcast receivers, for short-wave receivers, and for all-wave receivers. The book is written in simple style. Various types of aerials for the amateur transmitting station are explained, so you can understand them. It eliminates, once and for all the confusion about the type of aerial to choose for best broadcast and short-wave reception. For the thousands of radio fans, both short-wave and broadcast, who wish to know just what type of antenna they should use and why, this book has been especially published.

ALTERNATING CURRENT FOR BEGINNERS

This book contains everything to give the beginner a foothold in electricity and Radio. Electric circuits are explained. Ohm's Law, one of the fundamental laws of radio, is explained; the generation of alternating current; sine waves; the units—volts, amperes, and watts are explained. Condensers, transformers, A.C. instruments, motors and generators—all these are thoroughly discussed. Home-wiring systems, electrical appliances and electric lamps.

Here are some of the practical experiments which you can perform at home. Simple tests for differentiating between alternating and direct current; how to light a lamp by induction; making a simple electric horn; demagnetizing a watch; testing motor armatures; charging storage batteries from A.C. outlet; testing condensers with A.C.; making A.C. electro magnets; frying eggs on a cake of ice; making simple A.C. motors and many others.

Remember, these books sell at the extraordinary low price of ten cents; you can not possibly go wrong in buying them. Despite its low cost, our usual guarantee goes with this book as well!

IF YOU DO NOT THINK THAT THESE BOOKS ARE WORTH THE MONEY ASKED FOR THEM RETURN THEM WITHIN TWENTY-FOUR HOURS AND YOUR MONEY WILL BE INSTANTLY REFUNDED.

Each book is uniform in size and contains 32 pages of well-illustrated text.

There has never been such a wealth of data published in low-priced radio books of this type in the history of the radio publishing business.

Take advantage of the special offer we are making and use the coupon below.

RADIO PUBLICATIONS
101 Hudson Street
New York, N. Y.

Send for our FREE circular listing
48 new 10c Publications

Short-Wave Scout Reports

(Continued from page 420)

The "California Duck" Reports

● WHILE staying in Japan, my Patter-son PR-16C worked fine. The following list represents the stations logged between 5:30 p.m. and 10:30 p.m., J.S.T. Most of these stations are on 20-meter phones, and some are on 40 meters.

KA1AN, KA1AK, KA1ME, VS6AF, VS6AG, VS6AQ, (VK3ME), VK3KX, (VK2ME), VK6AJ, (VK3LR), VK2UD, VK2BQ, VK3NX, VK5WJ, PK4AU, PK6HA, PK1MX, J3EM, J4CD, J7CB, J8CJ, J8CC, XU3FP, XU8MT, VU2BG, W6JYH.

I also heard: ZCK, ZBW, I2RO, KZRM, KAZ, PMA, PLP, JVF, JVN, JVM, JVU, JVT, JYS, JVE, JMP2, JIB, JVI, JCO, GSF, GSB, GSE, RNE, RV15, XGOX, HS8PJ, Radio Colonial, and Chinese (BC) XGOA, and XMHA.

I heard hundreds of phones on both short waves and BC, but they speak too fast, therefore, I was unable to identify them. Also, I forgot to mention that I heard all of the Japanese "broadcasting" stations including MTCY, the powerful Manchoukuo "BC" station.

Veris were received for PK1MX, J3EM, J7CD, XU8MT, J5CC, MX2A, MX2B, and HS8PJ, together with numerous SWL cards.

I received a letter from the Bangkok Experimental Short-Wave Station HS8PJ, Post & Telegraph Dept., verifying my report on their station, and requesting that when I next report I give the dates and times in terms of G.M.T. in order to simplify their work. HS8PJ operates on 27.38 meters, or on 10.955 meg. It announces in Chinese, French, and English.

I am in Hawaii now and hoping to exchange SWL cards with SWL's and "Hams" from all over the world.

Also, I heard W6JYH on 20 meter phone talking to KA1AK, QSA5R-4-6. 73 to all.

Oriente I. Noda,
"California Duck"
817 Sheridan St.,
Honolulu, Hawaii, T.H.

O. L. P. Report from Parma, Ohio

● THE following is a resume of the stations heard at this O.L.P.:

EAQ on 30.40 meters on Aug. 14th at 6:45 to 7:15 p.m. This is the first regular broadcast since the "Revolution" started; using auxiliary power. Fair.

SM5SX on 14,308 kc., Stockholm, Sweden. Working amateurs, and relayed a special program from Swedish National on Aug. 10th. 11:00 a.m. to 5:00 p.m. Very good.

Podebrady, Czechoslovakia on 11.76 mc. Broadcasting on Aug. 7th at 5:35 to 6:00 p.m. Very poor at times. Announcing by man and woman. Symphonic music.

LZA on 14.97 mc. Sofia, Bulgaria. Broadcasting on July 28th at 1:15 to 1:45 p.m. Fair.

Belgrade, Yugoslavia. Broadcasting on July 26th at 5:15 to 5:30 p.m. Poor; terrific static.

VPD on 13.75 mc. Aug. 6th 12:30 to 1:30 a.m. Musical program. Fair. Veri rec.

WPT on 36 mc. (about) San Juan, P.R. (W.I.) working WNC. Very good.

VP3MR on 7:08 mc. Aug. 6th at 6:45 to 7:15 p.m. Fair. Code interference.

COCQ on 9.72 mc. Havana, Cuba. New station heard every evening 6:00 p.m. to 1:00 a.m. Very good.

W10XAD on 14.15 mc. Schooner Morrisey working amateurs. Good. Aug. 2nd, 4th, 5th, and 7th.

HBJ on 14.55 mc. and HBH on 18.48 mc. Working WQV, N.Y., on July 28 at 12:50 to 1:35 p.m. Also broadcast special program to U.S.A. Very good.

HH2T on 11.57 mc. Port au Prince, Haiti, (W.I.) broadcasting on July 26th at 6:30 to 7:00 p.m. Good.

DZH & DZE sent a special program for

RADIO PUBLICATIONS SW-11-36
101 Hudson Street
New York, N. Y.

Please send immediately books checked:
 How to Build Four Doerle Short-Wave Sets, No. 1.....10c
 How to Make the Most Popular All-Wave 1- and 2-Tube Receivers, No. 2.....10c
I am enclosing.....c; the price of each book is 10c. (U.S. Coin or U.S. Stamps acceptable.) Books are sent postpaid.

Send me also your FREE circular listing 48 new 10c publications.....

Name.....
Address.....
City..... State.....

RADIO PUBLICATIONS SW-11-36
101 Hudson Street
New York, N. Y.

Please send immediately books checked:
 All About Aerials, No. 4.....10c
 Alternating Current for Beginners, No. 3.....10c
I am enclosing.....c; the price of each book is 10c. (U. S. Coin or U. S. Stamps acceptable.) Books are sent postpaid.

Send me also your FREE circular listing 48 new 10c publications.....

Name.....
Address.....
City..... State.....

Please mention SHORT WAVE CRAFT when writing advertisers

Every Radio "Fan" Needs These SHORT-WAVE RADIO MANUALS

There has been tremendous progress made in short-waves during the past few years, and only in the OFFICIAL SHORT-WAVE RADIO MANUALS will you find a true picture of the important developments. Whether the advancement has been in set design and construction, servicing, or in the short-wave field, all are published chronologically in these SHORT-WAVE MANUALS. The Manuals are edited by Hugo Gernsback and H. W. Secor.

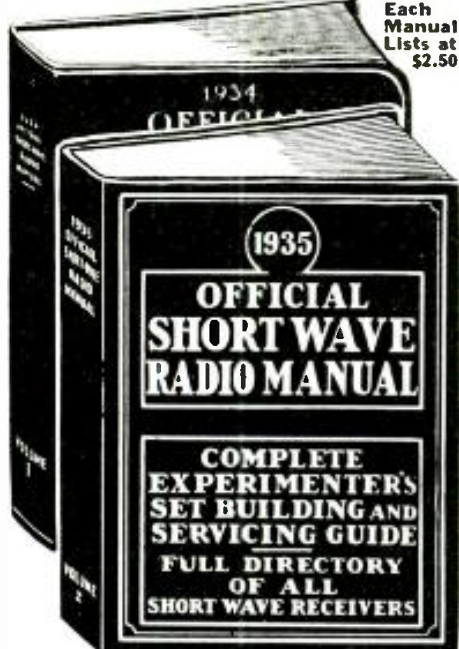

Each Manual Lists at \$2.50

Contents of the 1935 SHORT-WAVE MANUAL

Short-Wave Beginners' Section—Short-Wave Receivers—Matters Short-Wave Receivers—"5-Meter" Department—Short-Wave "Artificial Fever" Apparatus—Short-Wave Experimenters' Section—Ultra-Short-Waves—Commercial Short-Waves—How to Build "Power Supply" Units—Latest Short-Wave Converters—The Short-Wave Antenna—Superheterodynes—Phonic Transmitters for Amateur Stations—"Skip distance"—Headsible layer—Super-Regenerative Short-Wave Receivers—Recording Short-Wave Programs—High Fidelity—Short-Wave Questions and Answers—Short-Wave Kinks—Foreign Short-Wave Review—Tubes for Short-Wave Purposes—Short-Wave Transmitters—Multi-purpose Tubes—Auhn Amplifiers—"Band-Spread"—Ping-pong "Mino-gait" Receivers—Boosters, Pre-amplifiers and Heat Oscillators—Puddle Receivers and Transmitters—Short-Wave Service Data for Radio Service Men.

Contents of the 1934 SHORT-WAVE MANUAL

Important Short-Wave Receivers and how to construct them—Short-Wave Transmitters—Building one to seven tube receivers—Coil winding data—Commercial Short-Wave Receivers and Servicing Data—Kinks—Converters and their Construction—Antenna and Noise Eliminators—Superheterodynes—Amateur Phone Transmitters—Short-Wave Physics—theoretical short-wave data—Super-Regeneration in Short-Wave Sets.

Each Manual Contains Over 240 Pages—1,000 Illustrations Flexible, Looseleaf Leatherette Binder 9 x 12 Inches Special Combination Offer

To give every short-wave enthusiast the opportunity to add both SHORT-WAVE MANUALS to his library (Volume I and 2) both books, if bought together, can be purchased at a saving. Each Manual sells regularly for \$2.50. If both are bought together, the price is \$4.50. You save fifty cents.

SHORT WAVE CRAFT

99-101 Hudson Street New York, N. Y.

SHORT WAVE CRAFT SWC-1136
99-101 Hudson Street, New York, N. Y.

Gentlemen: I enclose herewith my remittance for which send me, postage prepaid, my copy of the OFFICIAL SHORT WAVE RADIO MANUAL as indicated below.

() 1934 Official Short Wave Radio Manual—\$2.50
() 1935 Official Short Wave Radio Manual—\$2.50
() Both Manuals—\$4.50.

Name

Address

City

State

Send Remittance by check, m-h, stamps or money order—register letter if cash or a mps are sent.

Please mention SHORT WAVE CRAFT when writing advertisers

Japan on Aug. 6th from 4:15 to 4:50 p.m. Good.

Wm. C. Palmer,
7240 Ridge Rd.,
Parma, Ohio.

Brecksville, Ohio, O.L.P. Short-Wave Log

Date	Time	Call	K.C.	Location	Remarks
1936					
July					
19	6:35	DJB	15,200	Germany	Very loud and clear
19	6:15	DJD	11,770	Germany	Very loud and clear
19	6:55	CJRX	11,720	Canada	Fair, faded
24	8:15	DJB	15,200	Germany	Very, very loud
24	8:25	DJD	11,770	Germany	Very loud, interference
27	7:00	GAW	18,200	England	Very loud
Aug.					
2	7:45	DJB	15,200	Germany	Exceptionally loud
2	7:55	GBS	12,150	England	Very loud
2	8:00	GSD	11,750	England	Very, very loud
2	8:10	DJN	9,540	Germany	Loud
2	8:20	DJA	9,560	Germany	Louder than DJN
2	8:30	COCU	9,428	Cuba	Steady, but weak
3	8:05	HJU	9,510	Columbia, S.A.	Loud and steady
4	9:20	TPA2	15,215	France	Steady, but weak
4	9:45	DJE	17,790	Germany	Steady, but weak
4	9:55	GSG	17,790	England	Clear, but faded
4	10:00	WNC	15,055	U.S.	Weak
4	11:15	W2XAD	15,330	U.S.	Loud
4	2:10	IAC	12,800	Italy	Fair, calling the "Rev"
4	6:50	HBJ	14,550	Switzerland	Very loud and clear
4	7:05	DJB	15,200	Germany	Very loud
4	7:20	EAQ	9,860	Spain	Very loud and steady
4	7:40	GSD	11,750	England	Very loud and clear
4	7:50	GSP	15,310	England	Loud and steady

Brecksville, Ohio, O.L.P. Short Wave Log. Time is E.S.

Date	Time	Call	K.C.	Location	Remarks
1936					
Aug.					
4	7:55	DJQ	15,280	Germany	Loud
4	10:10	W2XAA	6,080	U.S.	Very loud
4	10:50	HC2RL	6,660	Ecuador, S.A.	Weak, but understandable
5	4:45	HBJ	14,550	Switzerland	Very loud
5	4:50	JAH	14,600	Japan	Loud, but faded
5	5:05	DJL	15,110	Germany	Very loud
5	5:15	G8F	15,140	England	Clear and steady
5	7:20	PCJ	9,590	Holland	Very loud
5	7:30	CEC	10,670	Chile, S.A.	Loud, but static
5	7:35	TPA1	11,715	France	Fair, steady
5	7:38	2RO	11,810	Italy	Loud, signed at 7:40 p.m.
6	12:10	DJB	15,200	Germany	Steady, but weak
6	4:05	2RO	11,810	Italy	Very loud
10	3:45	DJB	15,200	Germany	Fair, calling Columbia B Sys
10	5:30	DML	15,110	Germany	Loud
10	5:55	2RO	11,812	Italy	Loud
11	6:45	JVM	10,740	Japan	Fair, choppy
13	7:35	HJYBA	11,810	Colombia, S.A.	Loud and steady
14	7:55	HJYABP	9,600	Colombia, S.A.	Very loud
14	8:30	Radio* Prague	About 15,200	Czechoslovakia	Loud, but slight hum. Testing

*Time given is L.S.T.
*New station of "The Czechoslovak Broadcasting Corp.", Prague, Czechoslovakia.

EDWARD M. HEISER,
Route 2, Box 124,
Brecksville, Ohio.

O. L. P. from Freeport, Pa.

● SOME of the newer (old stations on new waves) stations are:

HJYAB, on 9:56 meg.; TIPG, on 9.55 meg.; HC2J8B, on 9.51 meg.; HJU, on 9.51 meg.; and HJIABE.

EAQ, on 9.86 meg. has been holding the spotlight, due to the war conditions in Spain, but they don't seem to have the old-time "kick." At one time it was one of the best heard European stations. I would give DJB, on 15.20 meg., and

EVERY RADIO MAN IS TALKING ABOUT THE

BIG CONDENSER FIGHT

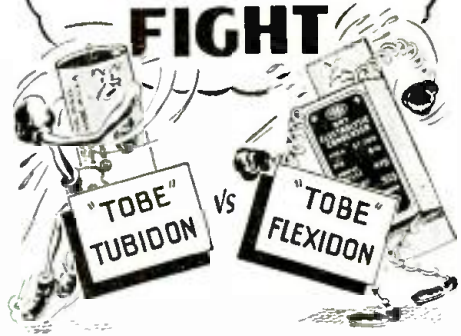

Tubular TOBE TUBIDON is a cinch to win, say some radiomaniacs. It's a self-supporting condenser, easy to install, uses less space, and actually costs less! But rectangular TOBE FLEXIDON has the one big feature, say others. It's "flexible" . . . if one section breaks down, due to overload, only that one section need be replaced. The units are completely separate. Our opinion is . . . BOTH ARE GREAT CONDENSERS! We leave it to you experimenters, servicemen, dealers, etc. to decide WHICH is best. All good supply houses have them. Do you want a catalog, and full technical description of these double-jacketed condensers? Please write today to TOBE DEUTSCHMANN CORP., Dept. L-11, Canton, Massachusetts.



ELECTROLYTIC CONDENSERS

Skillfully Manufactured at Canton, Mass.

1-Tube Air Scout Jr. \$1 Radio



\$1 WITH TUBE

A Real Radio—Keen Reception. Kit includes every part needed, including tube. These mount on 8 1/2" x 11" wood panel not in kit but easily made. Full-size picture layout, detailed instructions. Fun to build! Educational. Entertaining. Not a toy. Uses cheap batteries.

FREE: Genuine Find-All Coil used in Air Scout Jr. Sent postpaid on receipt 10c for handling costs. Extra 10c brings picture diagram with values of all parts.

H. G. Cisin, Chief Engineer
ALLIED ENG. INSTITUTE
Dept. S-30 98 Park Place New York, N.Y.

Sh! Silence!

That's what some member of your family would like to tell you but, out of consideration for your enthusiasm, holds back.



Use CANNONBALL HEADSETS

The favorite set of "Hams" and you will not only get clearer reception of all foreign programs but you will not disturb the rest of the family.

Write for illustrated circular S-11
C. F. CANNON COMPANY
SPRINGWATER, N.Y.

ONLY \$4.96 U. S. NAVY AIRPLANE-TYPE Microphone and Receiver

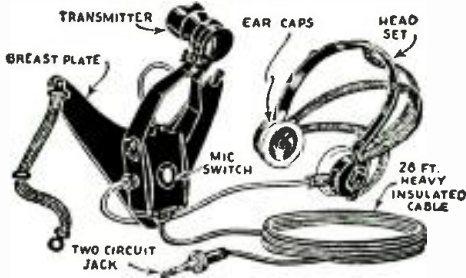

THIS Microphone and telephone headset outfit was built especially for the U. S. Navy Aviation Corps for Plane-to-Plane and Plane-to-Ground communication.

The Holtzer-Cabot Electric Company constructed the outfit to Government specifications and under rigid Navy Department supervision.

The outfit consists of a low-impedance carbon microphone (transmitter), securely fastened to a metal breastplate, and a set of heavy-duty, low impedance earphones. A specially constructed switch on the back of the breastplate controls the microphone circuit. The earphones are U.S.N. 'U' type, attached to adjustable headband. Twenty-eight feet of very heavy weather and waterproof conductor cable, terminating in a special brass plug, is furnished with this complete outfit. Current of not more than 10 volts should be used. A storage battery is the most satisfactory current supply. Talk in a natural tone of voice, when using the outfit, with the lips close to the mouthpiece. Shouting and loud talking should be avoided.

We understand that the U.S. Government paid more than \$40.00 for each of these outfits. We have bought the whole lot at a low price and are offering them, as long as the supply lasts, at \$4.96 each, complete as shown in illustration. The shipping weight is 9 lbs.

Merchandise in original packages— Never used—Money-back Guarantee.

All Shipments will be forwarded by Express Collect if not sufficient postage included.

WELLWORTH TRADING CO.
560 W. Washington Blvd., Dept. SW-1136, Chicago, Ill.

STOPPANI COMPASS

Thousands have been sold in all parts of the world. Cost the U. S. gov't. over \$30.00 each.



STOCK IS LIMITED

Rush your order before they are all sold.

Our price prepaid \$4.50 each

Gold Shield Products Co.

17 West 60th St. New York City



KEEP YOUR MAGAZINES CLEAN

With one year's subscription at \$2.50 or with 12 back numbers for \$1.50, we will furnish absolutely FREE a 10x12 1/2" stiff leatherette HOLDER. (For list of back numbers available, see page 451.)

This will permit you to keep your room or shack tidy and be able to find any magazine you are looking for without loss of time. This holder is large enough to keep all your magazines together.

Our supply is limited, therefore we would suggest prompt action.

SHORT WAVE CRAFT

99 Hudson St., New York, N. Y.

DJL, on 15.11 meg., the honors for the best heard short-wave stations this month.

The "Podebrady" Czechoslovakian stations are still testing; they do not have a regular schedule as yet. They are on 15.23 meg., 11.76 meg., and 6.115 meg. The power is about 30 kw. The station carrier has a peculiar hum, but it is not particularly bothersome. Their address is: Radio Podebrady, Podebrady, Czechoslovakia.

PHI, on 17.77 meg. is now coming in with very good volume.

RAN, on 9.52 meg. is heard very well.

RKI, on 15.08 meg., and RIM, on 15.25 meg. may be heard phoning each other at 9:00 a.m. every morning.

Angelo Centanino, Freeport, Pa.

Short Wave Scouts

(Continued from page 403)

- TGW-6000—Guatemala City, Guatemala.
- VE9DN-6005—Montreal, Canada.
- COC-6010—Havana, Cuba.
- HJ3ABH-6012—Bogota, Colombia.
- DJC-6020—Berlin, Germany.
- HP5B-6030—Panama City, Panama.
- PRAB-6040—Pernambuco, Brazil.
- HJ1ABG-6042 1/2—Barranquilla, Colombia.
- 2RO-1-6084—Rome, Italy.
- CRCX-6090—Bowmanville, Canada.
- XEFT-6120—Vera Cruz, Mexico.
- COCB-6130—Havana, Cuba.
- HJ5ABC-6150—Cali, Colombia.
- CJRO-6150—Winnipeg, Canada.
- YV3RC-6150—Caracas, Venezuela.
- H1A-6185—Santiago, D. R.
- TIPG-6410—San Jose, Costa Rica.
- HJ4ABC-6451—Ibague, Colombia.
- YV6RV-6520—Valencia, Venezuela.
- PRADO-6618—Riobamba, Ecuador.
- HC2RL-6660—Guayaquil, Ecuador.
- XECR-7380—Mexico, D. F.
- HAT-4-9125—Budapest, Hungary.
- COCH-9428—Havana, Cuba.
- PRF5-9501—Rio de Janeiro, Brazil.
- VK3ME-9518—Melbourne, Australia.
- DJN-9540—Berlin, Germany.
- DJA-9560—Berlin, Germany.
- 3LR-9580—Melbourne, Australia.
- HP5J-9590—Panama City, Panama.
- VK2ME-9590—Sydney, Australia.
- 2RO-3-9635—Rome, Italy.
- CT1AA-9650—Lisbon, Portugal.
- EAQ-9860—Madrid, Spain.
- V1Z3-11560—Sydney, Australia.
- HJ4ABA-11710—Medellin, Colombia.
- 11715—Paris, France.
- CJRX-11720—Winnipeg, Canada.
- DJD-11770—Berlin, Germany.
- 2RO-4-11810—Rome, Italy.
- ETB-11955—Addis Ababa, Ethiopia.
- RNE-12000—Moscow, U.S.S.R.
- HVJ-15120—Vatican City, Italy.
- DJB-15200—Berlin, Germany.
- PCJ-15220—Eindhoven, Holland.
- 15245—Paris, France.

Note: As this "log" was compiled quite some time ago, the frequencies given are different in many cases from the present ones.

ENGLAND

- DAVENTRY operates as follows during October (Subject to change). Trans. 1, 2:15-4:15 a.m. on GSD and GSB. Trans. 2, 6-8:45 a.m. on GSG and either GSH or GSF. Trans. 3, 9 a.m.-12 n. on GSG and GSF. GSH may be used also from 9-10:30 a.m. Trans. 4, 12:15-4 p.m. on GSO. GSD and GSB; 4-5:45 p.m. on GSF, GSD and GSB. Trans. 5, 6-8 p.m. on GSP, GSD and GSC. GSN or GSB may replace GSP. Trans. 6, from 9-11 p.m. on GSD and GSC.

Free Booklet on Code "Speed-Up"!

● An interesting booklet prepared by the Candler System on how to speed up on your code, is free for the asking. An article by Theodore R. McElroy, Official Champion Radio Operator of the World, describing how he learned to handle code with speed and accuracy is included.

All those interested in code transmission will do well to write for Booklet No. 515, Service Dept., Short Wave Craft, 99 Hudson St., New York City.

DATAPRINTS

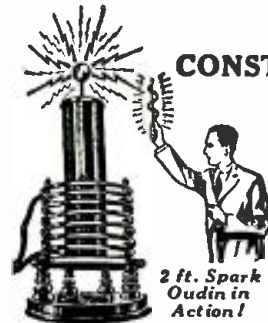

Just the CONSTRUCTION Information You Need To Build Electrical Apparatus

New LOW Price—3 Prints \$1.00

TESLA OR OUDIN COILS

Dataprint containing data for constructing this 3 ft. spark Oudin-Tesla coil. Requires 1 K.W. 20,000 volt transformer as "exciter"; \$1.50 see list below. Includes condenser data. . .

8 inch spark data for building, including condenser data; requires 1/4 K. W. 15,000 volt transformer; see list below. . . 0.50

Violetta type, high frequency coil data; 110 volt A.C. or D.C. type; 1" spark; used for "violet ray" treatments and "Experiments" . . . 0.50

How to operate Oudin coil from a vacuum tube oscillator . . . 0.50

8 inch spark Tesla coil; operates on Ford ignition coil . . . 0.50

8 inch spark Oudin coil; 110 volt A.C. "Kick-Coil" (Vibrator type) . . . 0.50

20 Tricks with Tesla and Oudin Coils . . . 0.50

TRANSFORMER DATA

1 k.w. 30,000-volt transformer data. 110-volt, 60-cycle primary. Suitable for operating 3 ft. Oudin coil . . . 0.50

1/4 k.w. 15,000-volt transformer data. 110-volt, 60-cycle primary. Suitable for operating 8-inch Oudin coil . . . 0.50

Electric Welding Transf. (2 K.W. 110 Vt. Prim. 18 Vt. Sec. Other Sec. Vt. data given) . . . 0.50

Induction Coils—1 to 12 inch spark data . . . 0.50

ARTIFICIAL FEVER Apparatus . . . 0.50

(Low, Medium & High Power Data Given)



SLIDE RULE MIDGET

Metal 4" Dia. Price \$2.00 Net.

With case and instructions

This rule solves any problem in multiplication, division, addition, subtraction, and proportion; it also gives roots and powers of numbers, sines, cosines, tangents and cotangents of all angles; also logs of numbers. Adds and subtracts fractions. Approved by colleges.

8" Dia. 25" Scale "Special" Rule. \$5.00 Net.

TELEGRAPHONE—(New Design) Records Voice or "Code" signals on steel wire by magnetism. Code can be recorded "fast" and translated "slow." Construction data (special) . . . \$0.50

MAGNET COIL DATA

Powerful battery electro-magnet; lifts 40 lbs. . . \$0.50

110 Volt D.C. magnet to lift 25 lbs. . . 0.50

110 Volt D.C. 300 lb., Lift electromagnet . . . 0.50

110 Volt D.C. solenoid; lifts 2 lb. through 1 in. . . 0.50

110 Volt D.C. solenoid; lifts 8 lb. through 1 in. . . 0.50

12 Volt D.C. solenoid; lifts 2 lb. through 1 in. . . 0.50

A. C. Solenoid, powerful, 110-volt, 60-cycle . . . 0.50

MOTOR—1/16 H.P., 110 volt A.C., 60 cycle (suitable for driving 12" fan, etc.)—Data . . . 0.50

MISCELLANEOUS DATAPRINTS

50c each Prepaid . . . 3 Prints for \$1.00

Radio Control for Model 60 or 1200 cycle Synchron. Motor

Electric Refrigerator Data Induction Balance

Treasure or Ore Locator Telautograph

Water Turbines Einthoven String Galvanometer

Water Wheels Electric Fan Motor

Motor Circuits (20) Watch Demagnetizer

Telephone Hook-ups (20) Electric Furnace Draft Regulator

100 Mechanical Movements Building a Simple Telephone

Polarized Relay, Ultra-sensitive Ignition Coil Data

Shocking coil Battery Motor (small)

Ring 4 bells on 1 circuit Wheatstone Bridge

20 Simple Bell Hook-ups Rotary Converter

Public Address System

Electric Chime Ringer

Fits any clock

20 "Electrical Tricks" for LODGES and PARTIES . . . \$0.50

How to Fry Eggs on Cake of Ice Electrically . . . \$0.50

"Rewinding" Small Motor Armatures . . . 0.50

New LOW Price—3 Prints \$1.00

The DATAPRINT COMPANY

Lock Box 322 RAMSEY, N. J.



RADIO'S LIVEST MAGAZINE
 Edited by HUGO GERNSBACK

RADIO-CRAFT is devoted to general Radio in all its phases, to Radio Servicing and to the advanced set builder and Radio Technician. Kinks show simple ways out of difficult problems. The latest radio equipment is illustrated and described.

8 Months for \$1.00

RADIO-CRAFT is fully illustrated with photographs, diagrams and sketches. Each issue contains over 150 illustrations. Sample copy—15c.

RADIO-CRAFT
 99C Hudson Street New York, N. Y.

YOU MUST HAVE THIS BOOK

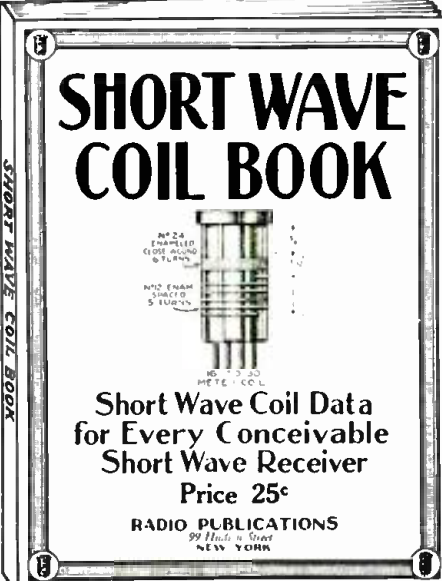

SHORT WAVE COIL BOOK

Short Wave Coil Data for Every Conceivable Short Wave Receiver
 Price 25c

RADIO PUBLICATIONS
 99 Hudson Street New York

It is now possible for the experimenter and short wave enthusiasts to obtain the most exhaustive data on short wave coil winding information that has ever appeared in print. As every experimenter who has ever tried to build a short wave set knows only too well by experience, the difference between a good and a poor receiver is usually found in the short wave coils. Very often you have to hunt through copies of magazines, books, etc., to find the information you require.

Between the two covers of this book you now find every possible bit of information on coil winding that has appeared in print during the past two years. Only the most modern "dope" has been published here.

No duplication. Illustrations galore, giving not only full instructions how to wind coils, but dimensions, sizes of wire, curves, how to plot them, by means of which any coil for any particular short wave set can be figured in advance, as to number of turns, size of wire, spacing, etc. There has never been such data published in such easy accessible form as this.

FRIENDS PESTER HIM

Dear Sirs:
 I received your Short Wave Coil Book and am very well pleased. I showed it to my radio friends and now they are always pestering me for coil data. hi hi!

BERNARD A. DECKELMANN,
 11348 So. State St., Chicago, Ill.

RADIO PUBLICATIONS
 97 Hudson Street, New York, N. Y.

Radio Publications, 97 Hudson Street, New York, N. Y. 11-36

Please send immediately, your Short Wave Coil Book, for which I enclose 25c herewith (coin, U. S. stamps or money order acceptable). Book is to be sent prepaid to me.

Name

Address

City and State

When to Listen In

By M. HARVEY GERNSBACK
 ALL TIME IS EASTERN STANDARD
 DAYLIGHT SAVING

● DAYLIGHT Saving Time ends in the U.S.A. and Canada the last Sunday in September and in Europe on either the first or second Sunday in October. The schedules of most of the stations in the U.S. and Canada will be affected. They will open up and sign off one hour later than heretofore. The corrected schedules appear in the station list.

In Europe the schedules of the Dutch, Portuguese, French and Belgian stations are the only ones affected. All others continue as before.

FRANCE

● THE following schedule goes into effect for the French stations when Daylight time ends there. 2-2:55 a.m. on 15245 and 11880 kc.; 2:55-5 a.m. on 11880 kc.; 5:55-11 a.m. on 15245 kc.; 12:15-6 p.m. on 11880 kc.; 6:15-10:15 p.m. and 10:45 p.m.-1 a.m. on 11715 kc.

U.S.S.R.

● THE new Moscow stations which were known as RW96 now identify themselves as RAN. The transmitter that was operating on 9520 kc. has shifted to 9600 kc.

We have received word from the operators of RV15 at Khabarovsk, Siberia. that a program is broadcast in English on every odd day of the month. This program commences at 3:20 p.m. Khabarovsk time which, we believe, is equivalent to 1:20 a.m. EST.

SWEDEN

● SM5SX, an amateur station at Stockholm has been heard broadcasting irregularly from 6-8 p.m. on the 20 meter band and also on 11770 kc.

AFRICA

● WE have received word from M. Wasserzug of Johannesburg, S. Africa, that there is an experimental station at Roberts Hgts., S. Africa. It is ZUD on 5000 kc. or 60 meters. The station tests irregularly. Reports should be addressed to the Chief Engineer, G. P. O., Pretoria, S. Africa. From the same source we learn that CRTAA at Lourenco Marques, Mozambique, Africa, operates on 6137 kc. daily from 4:15-6:15 a.m. and 12:45-3 p.m. and on Sun. from 8-11 a.m.

CUBA

● A station, COCX, at Havana has been heard recently relaying CMX from 6 p.m. till as late as 2 a.m. The schedule is unknown. The stations wanders from 11500 to 11700 kc.

CZECHOSLOVAKIA

● PRAGUE now broadcasts daily at 4 a.m., 11 a.m. and 2 p.m. on either 15230 kc., 11760 kc., or 6137 kc. An "American Hour" is broadcast on Mon. and Thur. from 9-11 p.m. on either 15230 or 11760 kc. It is on the air for about 2 hours in the last session. It has not been heard using the other frequencies recently. The transmissions are still experimental.

GERMANY

● THE latest schedule is: For South Asia, 12:05-5:15 a.m. on DJA and DJB; 5:55-11 a.m. on DJB. For East Asia, 12:05-5:15 a.m. on DJN and DJE; 5:55-7:15 a.m. on DJE; 7:15-11 a.m. on DJE and DJQ. For Africa, 12 m.-2 a.m. on DJL; 11:35 a.m.-4:30 p.m. on DJD and DJL. On Sundays also from 6-8 a.m. on DJL.

For South America, 5-7 a.m. on DJQ; 4:50-10:45 p.m. on DJN and DJQ. For Central America, 8-10 a.m. on DJR; 4:50-10:45 p.m. on DJA.

FOR NORTH AMERICA, 8-10 a.m. on DJL; 4:50-10:45 p.m. on DJD and DJB and sometimes DJL. Also on Sundays from 11:10 a.m.-12:20 p.m. on DJB.

HOLLAND

● THE latest schedule of the "Dutch Twins," PCJ and PHI follows: On Sundays PCJ, 15220 kc. 7-8 a.m.; 9590 kc. 2-3 p.m. and 7-8 p.m. On Tuesday PCJ, 15220 kc. 4:30-6 a.m.; on 9590 kc. 1:30-3 p.m. On Wednesday PCJ, 15220 kc. 8-11 a.m.; 9590 kc. 7-10 p.m.

PHI on 17775 kc. broadcasts daily except Tuesday and Wednesday from 8-10 a.m.

PRECISION



If you could see the extreme precision with which Cornell-Dubilier capacitors are manufactured, you would be better able to understand the fact that C-D condensers are leading in the race for sales.

Take Type TD for example. Hermetically sealed in NON CORROSIVE containers, these units are impregnated and filled with "Dykanol A", whose high dielectric strength and constant permits these mighty capacitors to be assembled in compact units, at least 50% smaller than units of similar rating have heretofore appeared. "Dykanol A" is so efficient that these capacitors may be operated at voltages 10% in excess of their rated voltage, without damaging the unit.

C-D Condensers are the standard by which others are judged. Thousands of "Hams" and DX fans use them and recommend them. Insist upon C-D's when you next visit your jobber.

Catalog 133A free upon request.

MICA • PAPER • DYKANOL WET AND DRY ELECTROLYTIC
 Extreme Adaptability to Every Circuit Requirement

CORNELL-DUBILIER CORP.
 1027 Hamilton Blvd. So. Plainfield, N. J.

CORNELL DUBILIER

BUD IMPROVED MIDGET CONDENSERS

Note These Improved Features!



1. New Positive Wiping Contact on rotor shaft with adjusting screw, eliminates mechanical noise on high frequencies.
2. Close Fitting Bearings hold rotor calibration and smoothness of operation.
3. Insulated with ISOLANTITE. Soldered brass plate assemblies, and heavy aluminum end plates make a precision built, ruggedly constructed condenser.
4. Shaft extends 5/16" beyond rear bearing for gauging several units with flexible couplings.

Dual units and multiple space units in various capacities illustrated and described in our new catalog. Free upon request!

40% DISCOUNT TO AMATEURS

BUD RADIO, INC. 1937 E. 55th St. Cleveland, Ohio

TELEVISION is Here!

Get Ready for Nation-Wide Activity

"Electronic Television" Gives all Facts and Practical Working Information. Only \$2.50

Get this newly published non-technical book. Prepare for Television's big opportunities. Covers everything, including methods, apparatus, wiring diagrams. Authorized by R. C. A. and Farnsworth, leaders in Electronic Television development. Material never before in print. Flexible binding. 182 pages. Illustrated. Postpaid only \$2.50. Money back if not satisfied. Order Electronic Television today and ask for catalogue FREE.

THE GOODHEART-WILCOX COMPANY, INC.
 (Publishers of Dyke's Auto Encyclopedia)
 Dept. 48, 2009 Michigan Avenue, Chicago.

New—Authorized Authentic Tells about cathode ray, iconoscope, kinescope, and other new Television developments.

Please mention SHORT WAVE CRAFT when writing advertisers

SWAPPERS

The names here listed are those of readers who would like to hear from other short-wave "fans." There is no charge for this listing—just sign your name and address on a postcard and address it to "SWAPPERS" in care of this magazine.

E. ABRAMS
512 Rosedale Ave., Bronx, N.Y.

GEORGE ALEWYNE
1420 College Ave., Conway, Arkansas

L. ALEXANDRE
60 East 119th St., New York City

HARRY R. ANDERSON
216 Rice St., Little Rock, Arkansas

THOMAS ANTRIM
214 Oakwood St., Bradford, Ohio

EVERETT ARNES
Northwood, North Dakota

J. GORDON BACH
206 Kelso Rd., Columbus, Ohio

WM. BATES
Rt., No. 2, Sarahsville, Ohio

HENRY BATHA
1409 S. 57th St., Cicero, Ill.

RICHARD BECK
2651 Summit St., Columbus, Ohio

NORMAN N. BERG
24 Salisbury Rd., Umgeni, Durban, South Africa

CHARLES BERNSTEIN
Sea View Hospital, Staten Island, N.Y.

THEO G. BESEPARIS
128 W. Arch St., Frackville, Pa.

JERRY D. BLISS
Box 574, Virginia City, Nev.

WILLIAM BREWIN
13, Ings Rd., Leeds, 9; Yorkshire, England

RAYMOND BROOKS
828 East 16th St., Chester, Pa.

ROY BROWN
Madison, Ga.

RALPH M. CECIL
Box 64, Harrison Co., Tippecanoe, Ohio

ERNEST V. E. CLOUSE
Quarter "Q," Mare Island, Calif.

JAMES CONLEY
319 So. Mulberry St., Marshall, Mich.

DALE CURRY
337 W. Central Ave., St. Paul, Minn.

O. A. DAVISSON, Jr.
1135 Convention, Baton Rouge, La.

RICHARD DAWSON
1308 F. Street, The Dalles, Ore.

EDWARD DE LAET
117 E. Parkwood Dr., Dayton, Ohio

JACK ELERY
Box 2, Larwill, Ind.

ALBERT E. EMERSON
1049 East 147th St., Collinwood, Cleveland, Ohio

DICK ERB
R. R. 3, Stratford, Ontario, Canada

RALPH EVERT, Jr.
1221 Fishers Ave., Philadelphia, Pa.

WALTER H. FIERS
42 Overlook Ave., West Orange, N.J.

FRAN FOLCK
723 N. 5th St., Vincennes, Ind.

LLOYD W. FROHRING
2636 E. Overlook Rd., Cleveland Hghts, Ohio

HENRY A. GOWING, Jr.
41 Vineyard Rd., Newton, Mass.

JAMES GROLL
N. Chicago St., Dwight, Ill.

ANTHONY GUIDE
15 Wolcott St., Malden, Mass.

WM. HARRIS
23 So. Brd., Mt. Ave., Frackville, Pa.

JOSEPH HELLMANN
48-12 46th St., Woodside, N.Y.

GEORGE HERKERT
3959-65 St., Woodside, N.Y.

JACK P. HOTCHKISS
200 W. Washington St., Colfax, Ia.

W. HOWE
3 Headley Ter., Irvington, N.J.

WILLIAM HUGHES
840 E. Ontario St., Philadelphia, Pa.

ARTHUR B. JOHNSON
472-83rd St., Brooklyn, N.Y.

BAYARD W. JOHNSON
Box 173, Kissimmee, Fla.

BURT S. KEMP
67 Myrtle Ave., Webster, Mass.

CHARLES KRIER
2676 Summit St., Columbus, Ohio

JOHN KUHN
232 Mt. Olivet Lane, Baltimore, Md.

SPENSER E. LAWTON
15 Hillside Ave., Westerly, R.I.

JAMES LEE
195 Felis Ave., Medford, Mass.

JACK LYNCH
122 Williston Ave., Waterloo, Ia.

NORRIS McKAMEY
1220 W. 7th St., Davnport, Ia.

ANTHONY MAGISTRO
2091 Third Ave., New York City

JACK J. MARTIS
209 East 97th St., New York City

ADAM MAZON
R. D. 4, Box 75-A, Lalrobr, Pa.

LYLE C. NEWELL
Beauregard Village, Claremont, N.H.

J. BERNARD NEWMAN
9 Pleasant St., Bridgton, Me.

ROBERT NEWMAN
1700 East 15th St., Brooklyn, N. Y.

KNUTE H. NIELSEN
Rte. 1, Box 148, Charleston, Ark.

RALPH PEASE
Ashfield, Mass.

EDWARD PETERS
Post Falls, Idaho, Box 173

FRANK PETERS
Box 152, Post Falls, Idaho

DICK PHILLIPS
Barker, N.Y.

KARL POHLMAN
219 S. Main St., Spencerville, Ohio

EDWIN PROND
11636 Parnell Ave., Chicago, Ill.

GRANT RICHARDSON
Rt. 3, Box 58, Kingston, N.Y.

W. T. ROBERTS
93 S. Bradford St., Gainesville, Ga.

ROBERT W. RUSSELL
519 Crystal Ave., Findlay, Ohio

THEODORE SCHACHAT
46 Clove Rd., New Rochelle, N.Y.

EDWARD SCHOFIELD
1925 Lincoln St., Wilmington, Dela.

GEORGE SELIKOWITZ
201 West 92nd St., New York City

W. R. SILBER
1036 N. Pilgrim St., Stockton, Calif.

JAMES TAYLOR
101 Fall Rd., Badin, North Car.

CLARENCE TETER
1229-7th St., Lorain, Ohio

RALPH I. THOMAS
Box No. 155, Hillsboro, N.C.

WILBUR TIPTON
1212 - 7th St., Lorain, Ohio

EMILE D. URANGA, Jr.
1901 - 16th St., Tampa, Fla.

PETER VAN DER WIEL
93 East North St., Iilon, N.Y.

J. K. WARD
73 Cavell Ave., Toronto, Canada

GEORGE R. WARREN
2345 Desplaines St., Blue Island, Ill.

LEO WASNIESKI
1143 Lincoln St., North Chicago, Ill.

PAUL WHITE
411 Wellington Rd., Mineola, L.I., N.Y.

WILLIAM WHITE
2286 McKinley Ave., Lakewood, Ohio

DONALD WILSEY
Selkirk, N.Y.

BERNARD E. WORNE
24 North 16th St., East Orange, N.J.

STANLEY ZAREMBA, Jr.
81 Sixth St., Norwich, Conn.

YOU CAN'T BUY THIS BOOK

SHORT WAVE GUIDE

With Your \$1.00 Subscription to Short Wave Craft You Get This Brand New Book **FREE**

The special subscription rate is 7 months for \$1.00. (Regular newsstand rate is \$1.75.)

Send the coupon today, with your remittance of One Dollar (\$1.00) when your subscription is received, a copy of our SPECIAL ANNIVERSARY GIFT will be sent to you—**POSTPAID**.

You do not have to be a new subscriber to receive this gift. If you are a subscriber at present, a copy of "SHORT WAVE GUIDE" will be sent you upon receipt of \$1.00, and we will advance your subscription by seven months.

SHORT WAVE CRAFT, 99G Hudson Street, New York, N. Y. 11

Gentlemen: Enclosed you will find my remittance of ONE Dollar (\$1.00) (Canada and Foreign \$1.20) for which enter my subscription for Seven Months to SHORT WAVE CRAFT. You are also to send me absolutely FREE, and postpaid, a copy of the Special Anniversary Gift Book—SHORT WAVE GUIDE.

Name

Address

City

State

Send remittance in form of check, money order or unused U. S. Postage Stamps. (Foreign: International Postal Money Order.) Register letter if it contains cash or stamps.

because it is our
Sixth Anniversary

FREE GIFT to YOU!

This year, SHORT WAVE CRAFT celebrates its Sixth Anniversary. Annual increases in circulation, plus authentic, exclusively short-wave editorial material, makes SHORT WAVE CRAFT unquestionably the leading magazine in its field. To commemorate this notable occasion, the Editors have written this outstanding book.

Partial Contents of Short Wave Guide

- Short-Wave Questions and Answers**
It is impossible to publish each month in SHORT WAVE CRAFT all the questions and their answers sent to us. We have printed with full illustrations, in SHORT WAVE GUIDE hundreds of important questions which have been recently received.
- Best Aerials for Short-Wave Reception**
The many elaborate antennas suitable for short-wave receivers often present problems for set owners. SHORT WAVE GUIDE will help you decide which aerial is best for your receiver. Many types of antennas are illustrated.
- Practical Hints on Short-Wave Tuning**
Hundreds of short-wave stations are heard by fans—and hundreds more could be heard distinctly if only you knew more about tuning them in. Expert advice on proper tuning is included in SHORT WAVE GUIDE.
- Short-Wave Kinks, Illustrated**
Every short-wave fan is interested in new kinks and shortcuts. Dozens of kinks reach us every week—and in SHORT WAVE GUIDE you will find a variety of them, carefully illustrated. They will prove very valuable to you.
- "Police Call" Receiver and How to Build It**
The most stirring signals on the air are police calls and every fan wants to hear these exciting alarms. Complete details for building and operating a "police call" receiver will be found.
- Simple, Efficient Short-Wave Receivers Which Anyone Can Build**
Complete construction plans for building many 1, 2 and 3-tube receivers will also be found. Schematic diagrams, lists of parts—everything you need to know to build these sets and make them function properly is included.
- A Simple "Ham" Transmitter**
There are thousands of fans who want to build a simple transmitter. Here is the ideal transmitter for beginners. It is practical, yet inexpensive to construct. List of necessary parts, wiring diagrams, and construction details are included.

Please mention SHORT WAVE CRAFT when writing advertisers

Westinghouse Power Generator

Manufactured for U. S. Signal Corps
200 Watt 110 V. AC

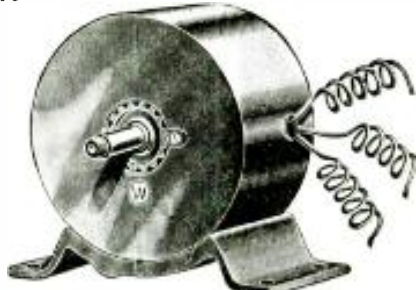

A. C. ELECTRICAL POWER

from a Windmill, from available Waterpower, from your Automobile, from your Motorcycle, from your Bicycle, Foot-pedals or Handcrank; operate A.C. Radio Sets in 110-volt districts; also A.C. Radio sets from 32 V. 110 V. faint light systems; use two generators in series to get 200 V. A.C. Use as an A.C. Dynamo, lights ten 20 Watt 110 Volt lamps; Short Wave Transmitter supplying 110 Volts A.C. for operating "Ham" Sets; Motor Generator; Public Address Systems; Camp Lighting; etc., etc.

There Are Over 25 Applications SPECIFICATIONS:

HOUSING—Aluminum (Diameter 6 1/2 in., Length—5 1/4 in.). SHAFT—2 3/8 in. driving end, Diameter—1 1/8 in. (the end is threaded for a distance of 1 1/2 in.). BASE—Cast Iron Length—7 1/2 in. Height 1 1/2 in. Width 4 1/2 in. OUTPUT—200 Watt 110 volts AC (speed 4200 R.P.M.). STATORS—Two pairs (two North and two South). ROTOR—12 tooth inductor. Built-in commutator. Rotor turns in ball bearings.

1 1/2 to 2 H.P. needed to run Generator.

BLUE-PRINT 22 x 28 in. and Four-Page 8 1/2 x 12 in. Applications and INSTRUCTION SHEETS FREE with Generator.

Generator, as described, including four replacement carbon brushes. Blue-print and instructions \$7.90

Send \$2.00 deposit balance C.O.D. Shipping weight 18 lbs.

(Replacement carbon brushes bought separate \$1.50 per set of four. Set of instructions bought separate \$1.00.) MONEY-BACK GUARANTEE

WELLWORTH TRADING COMPANY
560 West Washington Blvd., Dept. SWC-1136, Chicago, Ill. 606

Professional Model Ultra Violet SUN LAMP

This is a large Chromium plated lamp using standard carbons, emitting rays of ultra violet and infra red. If sun tan is desired, specify **SUN TAN CARBONS**

Complete with screen and goggles...\$7.50

Descriptive circular sent FREE.

Gold Shield Products Co.
17 W. 60th St. N. Y. City

Size 18" high, 7" wide, 5 1/2" deep. Weight 12 pounds.

Short Wave League Members

IDENTIFY THEMSELVES WITH THE ORGANIZATION

In order that fellow members of the LEAGUE may be able to recognize each other when they meet, we have designed this button, which is sold only to members and which will give you a professional appearance.

If you are a member of the LEAGUE, you cannot afford to be without this insignia of your membership. It is sold only to those belonging to the LEAGUE and when you see it on another, you can be certain that he is a member. See Page 448.

Lapel Button, made in bronze, gold 35c filled, not plated, prepaid.....

Lapel Button, like one described above, \$2.00 but in solid gold, prepaid.....

Short Wave League, 99 Hudson St., N.Y.C.

WOMAN'S DIGEST

OPENS A NEW ERA IN WOMEN'S MAGAZINES. It presents today's most urgent and serious problems for women, besides—international news, amusing articles, humor, travel sketches, prize contests, unusual recipes from all over the world—bits of entertainment and information.

Send 10c for sample copy or \$1.00 for the next 5 issues. Sold at better newsstands.

WOMAN'S DIGEST, 99-SW Hudson St., New York City

FREE S-W DATA SERVICE

Joseph Calcaterra, Director

Short Wave Craft Data Service,
99 Hudson Street,
New York, N. Y. SWC 11-36

Please send to me, without charge or obligation, the catalogs, booklets, etc., the numbers of which I have circled below.

- 2 3 4 5 57

My radio connection is checked below:

- Short-Wave Set Builder
- Short-Wave Experimenter
- Short-Wave Listener
- Service Man operating own business
- Service Man for manufacturer
- Service Man for jobber
- Service Man for dealer
- Service Man for servicing company
- Dealer
- Jobber
- Experimenter
- Professional Set Builder
- Amateur Set Builder
- Licensed Amateur
- Station Operator
- Radio Engineer
- Laboratory Technician
- Public Address Worker
- Manufacturer's Executive
- Student

My age is _____ years.
I have been interested in radio for _____ years.

I buy approximately \$ _____ of radio material a month. (Please answer this question without exaggeration or not at all.)

(Please Print Name and Address)

Name.....
Address.....
City..... State.....

AVOID DELAY. The catalogs and booklets listed are now in stock and will be sent promptly as long as the supply lasts. Only the items listed are available. Please make your selection from the current issue of *Short Wave Craft*, and use the coupon in ordering the items.

● THE catalogs, booklets, and folders listed in this department contain a wealth of information and data which will help you in your short-wave work.

These catalogs, booklets, and folders may be obtained by *Short Wave Craft* readers (without the trouble and expense usually involved in writing individual letters to the various organizations which publish them) through arrangements which have been made by *Short Wave Craft* magazine with the publishers of the literature listed.

To obtain any of the material listed in this department, simply draw a circle around each Booklet Number on the coupon, corresponding to the numbers of the items you would like to have, fill in the rest of the coupon and mail it to the *Short Wave Craft Data Service*.

A complete stock of these catalogs and other literature is kept on hand and will be sent to you promptly, as long as the supply lasts. There is no limitation on the number of items you may ask for, but to avoid waste, please do not ask for material in which you are not interested or of which you already have a copy.

Only the literature listed in this issue is available. Please do not ask for catalogs which are not listed. Do not include letters asking for information from other departments with your request for catalogs as that will cause delay in answering your inquiries.

2. HAMMARLUND 1936 CATALOG. Short wave fans and set builders will find a flock of
(Continued on page 449)

FOUR NEW THORDARSON CATALOGS

Tru-Fidelity Catalog No. 500

A complete listing of the entire Tru-Fidelity line of transformers. Profusely illustrated with working curves of each transformer. A complete treatise on the finest radio transformer built for commercial production.

FREE

Complete Transformer Catalog Catalog No. 400. No radio engineer, serviceman enthusiast or ham should be without this big 16 page catalog. Lists every radio transformer (except Tru-Fidelity) made by THORDARSON. Send for your copy today or see your radio parts distributor.

Radio Servicing Guide It's here! THORDARSON'S new 32 page Radio Servicing Guide. Check full of worthwhile suggestions. Profusely illustrated. Ideas on how to correct many problems in the service business. Send direct or buy it from your parts jobber.

Transmitter Guide Amateurs Attention! Europe and South America at your call. Thrill to trans-oceanic reception. Build finest amateur transmitters. Many other subjects treated in this book. Send direct or buy it from your radio dealer.

15¢

THORDARSON ELECTRIC MFG. CO.
500 W. HURON ST., CHICAGO, ILL.
Demand "Power by Thordarson"

NO ONE READS AND THEN DISCARDS SHORT WAVE CRAFT



Readers keep their copies for years as a steady reference and thousands of letters attest to this. It is now possible to save your copies and for this purpose we designed a splendid binder for you which holds twelve copies. It is made of heavy substantial material and is covered with black grain leatherette. The name of the magazine is stamped in gold on the cover.

An ingenious mechanical arrangement is provided which makes it possible to hold the copies flat when reading from the binder.

SHORT WAVE CRAFT Binder as described, \$1.25 prepaid in the United States.....

Canada and foreign countries 25c extra. We accept money order, check, stamps or cash.

SHORT WAVE CRAFT
99-101 HUDSON ST., NEW YORK, N. Y.

LEARN RADIO New Classes Now Forming! Send for 40-page catalog, explains fully, 300 licensed graduates placed in past 4 1/2 years in broadcasting, shipping, police radio, aviation, etc. We teach all branches. Oldest, largest and best equipped school in New England. Equipped with Western Electric sound and broadcasting equipment and RCA marine transmitter. Course prepares for United States Government telegraph or telephone license. Write Dept. S-11 for catalog.

MASS. RADIO SCHOOL, 18 Boylston St., Boston

Free S-W Data Service

(Continued from page 447)

new low-loss parts such as variable condensers, coil forms, sockets, transformers, chokes, shields, and other precision products especially designed for short-wave and ultra-short-wave work described in this catalog. Information on short-wave sets is included.

3. THE HAMMARLUND SHORT-WAVE MANUAL. No short-wave fan who is interested in short-wave set design should be without this 16-page manual, which contains constructional details, wiring diagrams and lists of parts of the day. A circular giving a description and 12 of the most popular short-wave receivers of list of contents of this manual is available free of charge to *Short Wave Craft* readers.

4. THE HAMMARLUND "COMET PRO" SHORT-WAVE SUPERHETERODYNE. This receiver is still holding its own as one of the leading short-wave receivers available for professional operators and advanced amateurs, for

work on 15- to 250-meter code and phone reception. It is especially adapted for laboratory, press, police, airport and steamship use.

5. ELECTRAD 1936 VOLUME CONTROL AND RESISTOR CATALOG. No short-wave set can function properly unless the volume controls and resistors are of the best. This catalog of resistors feature the latest developments in the resistor art. Fundamental volume and tone control circuit diagrams are given.

57. RIBBON MICROPHONES AND HOW TO USE THEM. How do your phone signals sound to the fellow at the receiving end? If they sound as though you're talking with a bunch of marbles in your mouth, the chances are a good microphone, properly hooked up, would help "to beat the band." This folder describes the Amperite Velocity Ribbon Microphone and gives information and circuit diagrams on how to connect up the microphone.

Short Waves and Long Raves

(Continued from page 402)

A BRICKBAT

Editor, SHORT WAVE CRAFT:

I am a high-school student who has been interested in radio since I was 12 years old when I began with broadcast sets. Later I began to build S-W sets; during this time your magazine has been invaluable.

I have built about three dozen of your sets, some good, some lousy. For instance, I sure got a lemon when I built the Doerle 2-tuber using 2-30's. But the Binnewig set was worth its weight in gold. I made it into a portable with another stage of audio, 33 pentode. I have heard all continents but Asia on the loud speaker, with only 45 volts of "B" voltage! Since then I have made eleven of them for my friends, because of its outstanding performances. Other sets I have made are, the Electrified Doerle, 4-Tube Super-Het., later the 2-Tube one, the Air-Rover, 2-Tube Regenerative Oscillodyne, Twinplex, Duo R.F. job, also the Voyager, 2-Tube DX-er and the Loop set. Just built the 1-tube Electric Oscillodyne in an old power transformer case for the portable. Am working on the "B S-4" now. Your dope on the tuning of doublets, April issue, has increased my signal ratings about 70 percent.

There are only a few complaints I have to make; one is all this "bunk" about no-code on 5 meters. I expect to get my ticket soon and when I get the parts together will go on 5-meter phone. Instead of wasting my time crabbing, I learned the code, it hasn't hurt me, it didn't take long. I don't regret the time I spent even if I am only interested in amateur phone.

Another thing is when you print a letter from someone who mentions SHORT WAVE CRAFT, you print the title in big letters. Why? It seems like "cheap stuff"; we all know that SHORT WAVE CRAFT is good, or we wouldn't read it. In all fairness it is only a minor thing, and other publications do the same. SHORT WAVE CRAFT is read by practically every radio fan in my high school. We appreciate it.

I hope this is printed for one reason, to encourage a lot of young fellows like myself, who have to sacrifice other pleasures to be able to work with short-wave radio. Radio is a great field for us "kids" who are still in grammar and high schools. I will be glad to hear from any old-timers, Hams, fans, or fellows my own age; all letters answered.

Many thanks to you and your staff and sincerest congratulations on the work that has made possible my work in radio.

STEWART E. DEGAETANO,
281 So. Columbus Ave.,
Mount Vernon, N.Y.

(Thanks for the brickbat, Stewart, and as we have received literally thousands of letters praising the phenomenal results obtained with the Doerle 2-tuber, and while the Binnewig set is a very good one, we believe that there was some little thing wrong with the Doerle as built by you, which caused it to fail in living up to its reputation. With regard to your statement that we seem to give special display to letters in which the writer mentions SHORT WAVE CRAFT, or that we print the title of the magazine in extra large type in all such letters, this is hardly fair. Naturally, the editor of any magazine would endeavor to emphasize the name of his publication wherever it was mentioned in a reader's letter, at least to some extent, and we can assure you that we do not read the letters for this department with only that object in view. Furthermore, we believe that you will agree that this is quite true, if you will but take the trouble to look through some of the back numbers and note the great variety of letters we have published in this department.—Editor)

D.C. 2-TUBE DOERLE WORKS FINE

Editor, SHORT WAVE CRAFT:

Having built the 2-tube Doerle D.C. set, I wish to advise you of the results I have received with it.

The first station I received with it was COC, Havana, Cuba; DJC, Berlin, Germany; 12RO, Rome, Italy; HP5B, Panama City, Panama; GSA, Davenport, England; YV2RC, Caracas, Venezuela; CJRX, Winnipeg, Canada; YV5RMO, Maracaibo, Venezuela; XEBT, Mexico City, Mexico; WOB, Lawrenceville, N.J.; WIXAL, Boston, Mass.; W2XE, New York; W9XAA, Chicago, Ill.; VE9GW, Bowmanville, Canada; W3XAL, Bound Brook, N.J.; W8XK, Pittsburgh, Pa. on two bands, W2XAF, W3XAU on two bands, W9XF, Chicago, Ill.; and many Spanish stations which I could not identify.

Not bad, eh? More luck to your magazine, and wish you would have more like it. And thanks for printing descriptions of such excellent sets as the Doerle.

AMBROSE McMULLEN,
567 Querbes Ave.,
Montreal, Quebec, Canada,

(Fine business, Ambrose, and your Doerle D.C. 2-tuber is certainly performing in fine shape. We presume that by this time you have rolled up quite an astonishing "log" of foreign as well as home stations.—Editor)

Please mention SHORT WAVE CRAFT when writing advertisers

POWER LINE NOISE ELIMINATOR

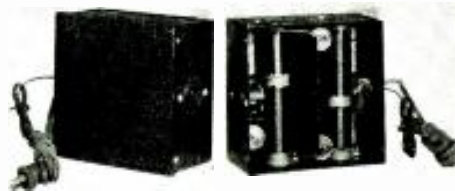

The same principle used in our own Laboratory screen rooms—a balanced filter containing noise-blocking inductances and noise-by-passing capacities. Completely BLOCKS OUT power line noise! Fully assembled \$7.20 net.

R9+ TUNED ANTENNA

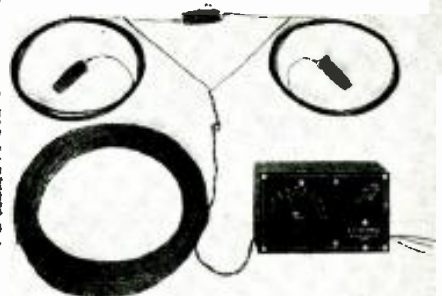

Beginning where all other antennae leave off. Brings to listeners a new era in short-wave reception. In practical tests the new R9+ has increased short-wave signal volume from three to six times over present antenna equipment. Fully assembled \$8.85 net.

McMURDO SILVER CORP.
Division of G.P.H., Inc.
1711 ROSCOE ST., CHICAGO, ILL.

The VIBROPLEX JUNIOR

New GENUINE MARTIN



ONLY \$10 with All Standard Improvements

Designed especially for Radio operating and incorporates mechanical features and improvements found only in the Genuine Vibroplex Bug . . . Provides greater precision in adjustment

—clearer, stronger signals and easier manipulation . . . Quickly establishes the user as a GOOD, RAPID sender with less than half the effort of ordinary key sending . . . May be operated as slowly as 5 w.p.m. or at any speed desired . . . Easy to learn . . . Easy to use . . . Easy to own at this low price . . . Over 100,000 Vibroplexes in use . . . Other models in Black or Colors, \$17; Nickel-Plated, \$19. Remit by money order or registered mail.

THE VIBROPLEX CO., Inc.
832 Broadway, Dept. S-11, New York, N. Y.

Order Yours To-day

WANTED BRANCH MANUFACTURERS

by old established firm, to cast Christmas goods, 5 and 10c Novelties, Toy Autos, Ashtrays, etc. Can be handled in any spare room, basement or garage. No experience necessary as we furnish full instructions with moulds. A rare opportunity for these times, so if over 21 and you want to devote your spare or full time to profitable work write AT ONCE for full details as we are now closing arrangements for supply of our goods.

METAL CAST PRODUCTS CO.
1696 Boston Road, Dept. 27, New York, N. Y.

SPECIAL FOR THIS MONTH

Send \$1.00 (\$1.25 Canada and foreign) and we will send you SHORT WAVE CRAFT for Eight months. "DO IT NOW"

SHORT WAVE CRAFT
99-101 Hudson Street New York

Here are the Six BEST SHORT-WAVE RADIO BOOKS!

Without doubt you will have to go a long way to buy better books on short waves than you find on this page. Each book is written by a well-known authority on short waves . . . each book has been carefully illustrated with photographs and diagrams to

make the study of this field of radio much simpler. The volumes on this page are the finest books on short-waves which are published anywhere today. Order one or more copies today . . . find out for yourself how fine they are. Prices are postpaid.

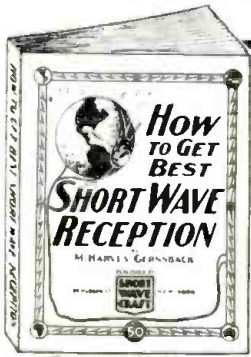

How to Get Best Short-Wave Reception

By M. HARVEY GERNSBACK

This book tells you everything you ever wanted to know about short-wave reception.

The author, a professional radio listener and radio fan for many years, gives you his long experience in radio reception and all that goes with it.

Why is one radio listener enabled to pull in stations from all over the globe, even small 100 watters, 10,000 miles away, and why is it that the next fellow, with a much better and more expensive equipment, can only pull in the powerful stations that a child can get without much ado?

The reason is intimate knowledge of short waves and how they behave. Here are the chapters of this new book:

1. What are Short Waves and what can the listener hear on a short-wave receiver or converter?
2. How to tune and when to listen in on the short waves.
3. How to identify short-wave stations.
4. Seasonal changes in short-wave reception.
5. Types of receivers for short-wave reception.
6. Aerial systems for short-wave receivers.
7. Variations from short-wave stations.

The book makes excellent reading matter. There are many tricks in short-wave reception that even some of the "old-timers" do not know. Be sure to get it.

40 Illustrations, 72 Pages.
Stiff, flexible covers

50c

HOW TO BUILD AND OPERATE SHORT-WAVE RECEIVERS

THIS is the best and most up-to-date book on the subject. It is edited and prepared by the editors of SHORT WAVE CRAFT, and contains a wealth of material on the building and operation, not only of typical short-wave receivers, but short-wave converters as well. Dozens of short-wave sets are found in this book, which contains hundreds of illustrations; actual photographs of sets built, hookups and diagrams galore.

This book is sold only at a ridiculously low price because it is our aim to put this valuable work into the hands of every short-wave enthusiast.

We know that if you are at all interested in short waves you will not wish to do without this book. It is a most important and timely radio publication.

150 Illustrations, 72 Pages.
Stiff, flexible covers

50c

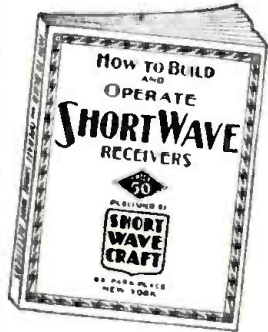

THE SHORT-WAVE BEGINNER'S BOOK

HERE is a book that solves your short-wave problems—leading you in easy steps from the simplest fundamentals to the present stage of the art as it is known today. It is the only low-priced reference book on short waves for the beginner. The book is profusely illustrated—it is not "technical." It has no mathematics and no technical jargon.

It also gives you a tremendous amount of important information, such as time conversion tables, all about aerials, noise elimination, all about radio tubes, data on coil winding and other subjects.

Partial List of Contents

- Getting Started in Short Waves—the fundamentals of electricity. Symbols, the Short Hand of It—how to read schematic diagrams. Short Wave Coils—various types and kinds in making them.
- Short Wave Aerials—the points that determine a good aerial from an inefficient one.
- The Transposed Lead-in for reduced Static.
- The Beginner's Short-Wave Receiver—a simple one tube set that anyone can build.
- How to Tune the Short-Wave Set—telling the important points to get good results.
- Audio Amplifiers for S-W Receivers.
- Learning the Code—for greater enjoyment with the S-W set. Wave length to Kilocycle Chart.
- Wire Chart—to assist in the construction of coils.

75 Illustrations, 40 Pages.
Stiff, flexible covers

25c

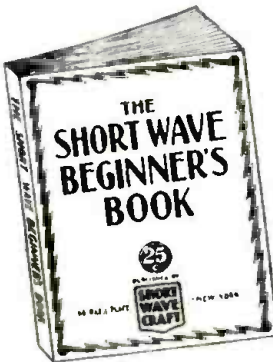

101 SHORT-WAVE HOOKUPS

Compiled by the Editors of SHORT WAVE CRAFT

EACH and every hook-up and diagram illustrated is also accompanied by a thorough explanation of what this particular hook-up accomplishes, what parts are required, coil-winding information, values of resistors, etc., in fact, everything you want to know in order to build the set or to look up the data required.

To be sure, all of the important sets which have appeared in print during the past five years are in this valuable book. Sets such as the Doerle, Dismore, the "P" Triplex, Oodilodra, Denton "Stand-By," Megadyne Triplex 2, "Globe-Trotter," 2-Tube Superhet, Minklyn, "Lion" Receiver, "Doerle" 2-Tube History, "Doerle" 3-Tube Battery, "Doerle" 2-Tube A.C., "Doerle" 3-Tube A.C., Doerle "Signal Gripper," Duo R.F. 4-Tube Receiver, The Sargent 9-33 Tapped Coil Receiver, Globe-Girdler 7, The 2-Tube "Champ"—2 Tubes Equal 3, Ham-Hand 2-Tube Post-War, Wyeath All-Wave 6, Denton Economy 3, 2-Tube "Regenerative Oodilodra" will be found here, with full descriptions. In many cases, we have also included a picture hook-up for those who do not wish to follow the regular symbolic hook-up, but wish to have a regular wiring diagram.

This is a very handy volume, especially for those "fans" who wish to study the best sets in the short-wave art, from one tube up to ten tubes.

100 Illustrations, 72 Pages, 50c
Stiff, flexible covers

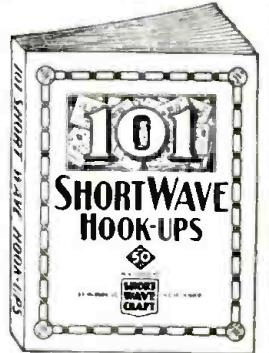

HOW TO BECOME AN AMATEUR RADIO OPERATOR

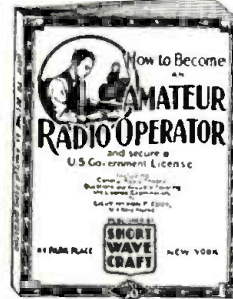

WE chose Lieut. Myran F. Eddy to write this book because his experience in the amateur field has made him prominent in this line. For many years he was instructor of radio telegraphy at the R.C.A. Institute. He is a member of the I.R.E. Institute of Radio Engineers, also the Veteran Wireless Operators' Association.

If you intend to become a licensed code operator, if you wish to take up Phone work eventually—this is the book you must get.

Partial List of Contents

Ways of learning the code. A system of sending and receiving with necessary drill words is supplied so that you may work with approved methods. Concise authoritative definitions of radio terms, units and laws, brief descriptions of commonly used pieces of radio equipment. This chapter gives the working terminology of the radio operator. Graphic symbols are used to indicate the various parts of radio circuits. General radio theory particularly as it applies to the beginner. The electron theory is briefly given, then waves—their creation, propagation and reception. Fundamental laws of electric circuits, particularly those used in radio are explained next and typical basic circuits are analyzed. Descriptions of modern receivers that are being used with success by amateurs. You are told how to build and operate these sets. Amateur transmitters. Diagrams with specifications are furnished so construction is made easy. Power equipment that may be used with transmitters and receivers, rectifiers, filter, batteries, etc. Regulations that apply to amateur operators. Appendix which contains the International "Q" signals, conversion tables for reference purposes, etc.

50c 150 Illustrations, 72 Pages, Stiff, flexible covers

TEN MOST POPULAR SHORT-WAVE RECEIVERS

—HOW TO MAKE AND WORK THEM

THE editors of SHORT WAVE CRAFT have selected ten outstanding short-wave receivers and these are described in the new volume. Each receiver is fully illustrated with complete layout, pictorial representation, photographs of the set complete, hookup and all other while specifications. Everything from the simplest one-tube set to a 5-Tube T. H. F. receiver is presented. Complete lists of parts are given to make each set complete. You are shown how to operate the receiver to its maximum efficiency.

CONTENTS

- The Doerle 2-Tube Receiver, That Reaches the 12,500 Mile Mark, by Walter C. Doerle.
- 2-R.F. Bandwidth Receiver having two stages of Tuned Radio Frequency, by Clifford E. Denton and H. W. Secor.
- My de Lusa S-W Receiver, by Edward G. Ingram.
- The Binneweg 3-Tube 12,000 Mils DX Receiver, by A. Binneweg, Jr.
- Build a Short-Wave Receiver in Your "Brief-Cases" by Hugo Gernsback and Clifford E. Denton.
- The Denton 2-Tube All-Wave Receiver, by Clifford E. Denton.
- The "Stand-By" Electrical, by Clifford E. Denton.
- A COAT-POCKET Short-Wave Receiver, by Hugo Gernsback and Clifford E. Denton.
- The S-W PENTODE 4, by H. G. Cahn, M. E.
- Louis Martin's Idea of A GOOD S-W RECEIVER, by Louis Martin.

75 Illustrations, 40 Pages, 25c
Stiff, flexible covers

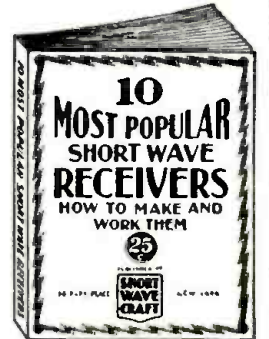

All the books shown on this page are published exclusively by

SHORT WAVE CRAFT

99-101 Hudson Street
New York, N. Y.

CLIP-MAIL

SHORT WAVE CRAFT, 99-101 Hudson Street, New York, N. Y. SWC-11-36

Gentlemen: I enclose herewith my remittance for the amount of \$..... for which you are to send me, postpaid, the books checked below.

- | | |
|---|---|
| <input type="checkbox"/> How to Get Best Short-Wave Reception..... 50c each | <input type="checkbox"/> How to Become an Amateur Radio Operator..... 50c each |
| <input type="checkbox"/> 101 Short-Wave Hook-ups..... 50c each | <input type="checkbox"/> Ten Most Popular Short-Wave Receivers. How to Make and Work Them..... 25c each |
| <input type="checkbox"/> How to Build and Operate Short-Wave Receiver..... 50c each | <input type="checkbox"/> The Short Wave Beginner's Book..... 25c each |

Name.....
Address.....
City..... State.....

(Send remittance in form of check or money order. If letter contains cash or unused U. S. Postage Stamps, register it.)

OVERSEAS READERS!

These books can be obtained from the following houses:

GREAT BRITAIN
Garringe's
9a, Green Street, Leicester Square
London, England

FRANCE
Editions Radio
42, Rue Jacob
Paris

AUSTRALIA
McGill's
183-195, 218 Elizabeth St.
Melbourne, C. I.

Please mention SHORT WAVE CRAFT when writing advertisers

New! 1936 EDITION

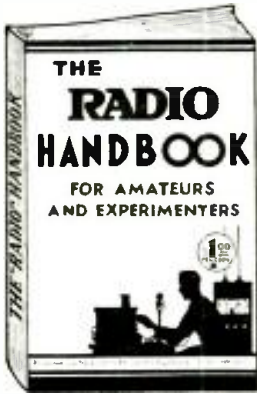

360 PAGES OVER 400 ILLUSTRATIONS AND DIAGRAMS

Complete Radio Course AND Valuable Reference Guide

- ★ Amateur and experimenters "sweat" by the facts in this new Handbook. No space has been wasted on matter which is not of practical use. Nothing of value has been omitted. The book is concise, to the point and profusely illustrated. **PARTIAL LIST OF CONTENTS:** Learning the Code, Fundamental Theory of Electricity, Theory of Vacuum Tubes, both receiving and transmitting, Receiver Design, Crystal Filters, A.V.C., Audio Circuits, Construction and Operation of transmitters, Famous Jones Exciter, Numerous Coil Winding Charts, Radio Telephony, Controlled Carrier Modulation, Complete 53 page chapter of 10 Meter and Ultra-High Frequency Equipment, Complete 25 page chapter on All Types of Antennas, Power Supplies, Test Instruments, Cathode Ray Oscilloscope and Its Application to Short-Wave Receivers and Transmitters, Regulations of the Federal Communication Commission and Board of Fire Underwriters, Complete List of "Q" Signals, etc., etc. Size 6"x9". Flexible card-board covers.
- ★ **ORDER TODAY.** Send \$1.00 plus postage (weight, 2 lbs.), 4 days for direct order accepted. Register letter if you send cash or unused U. S. postage stamps.



RADIO PUBLICATIONS
101 Hudson Street New York



JOIN NOW



Have You Friends or Relatives Needing Jobs?
Are You Looking for a Better Position?
Do You Want to Make Money?

On all newsstands 25c.
If your dealer cannot supply you, send a quarter and we will forward a copy at once

JOBS & CAREERS
520 N. Michigan Avenue, SW-1136, Chicago, Ill.

USW's May Lower Auto Death Toll!

Editor, SHORT WAVE CRAFT:
I have taken the time to write this letter, and hope you may also have the time to read it; as it only goes to prove your contention and mine that "99 per cent of short wave use has never been reached."

Recently, I became interested in waves below 1 meter, using low power, battery-operated and beam reflectors. The results did not seem satisfactory and the output seemed "jittery." Sensitive meters and neon indicators would be steady—then a fluctuation would occur.

I removed the small apparatus to the street, or rather a road known as Sprague Avenue, Tottenville, S.I. Fluctuations were even worse. Output would be running steady, and then for no reason at all the meter hand would jump. What could be absorbing this power? The plate and filament batteries were new and strong.

Then, Mr. Gernsback, I happened to glance towards Hylan Blvd. about 300 feet away. An automobile flashed by. I wondered if autos were affecting it. I decided to watch the indicators and keep an eye peeled towards Hylan Blvd. The meter flickered and a few seconds later a car went by. It flickered again, and still another car and from another direction. Then the indicators jumped badly—AND AN OIL TRUCK WENT BY. Everytime there was a flicker—an auto passed the junction of Hylan Blvd. and Sprague Ave.

Then—an idea was "borned," communication below one meter was quickly forgotten. Something presented itself of far more importance. Here was a means that has been overlooked for the preservation of lives of automobilists. Here was a method to provide the knowledge to a car operator that the road ahead was not clear—that a car was approaching.

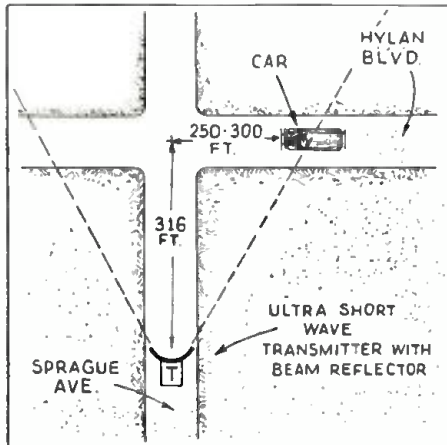

Diagram showing how "auto" is detected by its effect on U.S.W. Transmitter

With the help of an "understudy," a short wave portable receiver was installed on the roadside of Hylan Blvd., the transmitter being located at the point where the directional transmitter was located. When a fluctuation occurred a "dot" was flashed the Hylan Blvd. operator. He noted the position of the car by the parallel concrete splits in the pavement. This was marked with chalk. Due to the car moving fast it seemed to be within two concrete "squares." The receiver was moved to the opposite side of Sprague Ave., and experiments resumed as above.

We then had two markings showing the extremities of the wave and where the "absorption" occurred. This was measured and found to have approximately 250 to 300 feet each side of the "dead-center" of the junction of Sprague Ave. and Hylan Blvd. Then the distance from this dead-center and down Sprague Ave., was measured and found to have approximately the same distance. The exact distance being 316 feet. Now it was found that this very short wave, with the parabolic reflector and

(Continued on page 453)

6 BACK NUMBERS SHORT WAVE CRAFT MAILED PREPAID 70c

For a limited time only, and as long as they last, we will send you six back numbers of SHORT WAVE CRAFT assorted, your choice, for 70 cents.

The usual price for six copies would be \$1.50 and most publishers charge a higher price for back numbers over one year old.

We can supply only the following back numbers: Dec. 1930; Feb., April, June, Oct. 1931; Oct., Nov., Dec. 1933; Jan., Feb., Mar., April, May, June, July, Aug., Sept., Oct., 1934; 1935—All issues; 1936—All issues to date.

If you do not specify copies we will use our own judgment in sending assorted numbers to fill your order. Note we cannot exchange the copies for ones that have been sent to you.

Practically every copy of SHORT WAVE CRAFT contains important information that you should have. Here is a chance to get those copies.

As we have only a small supply of back numbers on hand, this offer will be withdrawn as soon as they have been sold.

We accept U.S. stamps, U.S. coin, or money order. Rush your order today.

SHORT WAVE CRAFT
99-101 Hudson Street New York, N. Y.

SHORT WAVE CRAFT 11-36
99-101 Hudson Street, New York, N. Y.

Gentlemen: I enclose herewith 70c, for which you are to send me six back number copies of SHORT WAVE CRAFT as follows:

Name
Address
City State

MAILING LISTS



GET OUR FREE REFERENCE BOOK and MAILING LIST CATALOG FREE

Gives counts and prices on accurate guaranteed mailing lists of all classes of business enterprises in the U. S. Wholesalers—Retailers—Manufacturers by classification and state. Also hundreds of selections of individuals such as professional men, auto owners, income lists, etc.

Write today for your copy

R. L. POLK & CO.
Polk Bldg.—Detroit, Mich.
Branches in Principal Cities
World's Largest City Directory Publishers
Mailing List Compilers, Business Statistics, Producers of Direct Mail Advertising.

VEST POCKET SOLDERING IRON

Smallest good iron now on the market. Will do the work of irons twice its size. Only 11 inches long, 1/2 inch in diameter. By using the highest grade elements, it heats up in half the time of ordinary irons. Guaranteed to give satisfaction or money back.

Sent Prepaid for \$1.25
Gold Shield Products Co., 17 West 60th St., N. Y. City

Please mention SHORT WAVE CRAFT when writing advertisers

Best and lowest priced WORLD GLOBES FOR SHORT WAVE LISTENERS

**World
Globe
No. P-100**



This beautiful floor model globe fills the demand for a globe of this type at a popular price. The 12" standard ball shows 67 prominent international short-wave stations—steamship routes, ocean currents, mountain peaks with heights, principal railroads, Lindbergh's flight and other important data will be found clearly printed on the globe.

The ball is mounted in a fully graduated, semi-meridian. The solid walnut base has been gracefully patterned to harmonize with the interior of home or office. The base is sturdily constructed.

A beautifully illustrated, 32-page book, "The Story of the Globe" is included with this model. It is full of interesting facts, including the question and answer globe-game. Height of stand, including 12" globe—34". Shipping weight—12 lbs. **\$3.95**
PRICE

THESE remarkable, new globes printed in a variety of popular colors are indispensable to short-wave fans. Notable among the many features of these world globes, is that they give life-time service. Short-wave fans are enabled to determine correct time in various centers of the world with the aid of these globes; distances from city to city can be accurately established.

There is a graduated "Meridian" scale on many of the globes. Another feature is the moveable hour scale found at the north pole—this facilitates determining the hour in any part of the world.

You will be thrilled when you put the globe to actual use—measuring distances from New York to Moscow; from Cape Town to Tokio; from Los Angeles to Rio de Janeiro; etc. A flat map is deceptive for measuring, but take a small string and stretch it across the globe, from city to city, and you have the correct distances.

Each globe contains a listing of several thousand cities in nations all over the world—spellings conform to international geographic standards—all globes are of 1935 production. They contain such important features as—traces of Admiral Byrd's recent voyage to Little America; Lindbergh's Paris flight; the new Japanese Empire; principal railroads; principal international short-wave radio stations and call letters; steamship routes; and other equally important data.

The colors on our fine handmade or Library globe maps are refined and delicate. Nevertheless, the two types have an essential characteristic in common—their rich color harmony, in which each color of equal strength blends into a harmonious color unit.

The map surface of all models is protected by a high, glazed, water and scratch proof finish which can easily be kept fresh and new with a damp cloth. This finish will not fade, crack or become yellow with age. The colors are sun proof.

These globes add dignity to home, office, studio or laboratory—they are globes that everyone will be proud to own.

World Globe No. P-88

This 8" standard globe, which has been the most popular seller includes many fine features. You will find Manchukuo, the new Japanese empire; thousands of place names; ocean currents; famous ruins; principal railroads; Lindbergh's flight; Little America; and other essential data.

With each of these beautiful globes you receive, FREE, a 16-page globe-game book "Do You Know...?" It contains 146 questions and answers about curious and fascinating geographic facts.

The 8" ball is mounted in a full meridian, carefully graduated. The ring, of unbreakable steel, is finished in stately bronze and gold. Height—11 1/4". **\$1.75**
Shipping weight—30 lbs. PRICE



U. S. Army Air Corps,
Dryden, Texas.

Gentlemen:
Receipt is acknowledged of the "Short Wave World Globe" which arrived okay today and am very well pleased with same. The writer desires to thank you for attention to this order.
The globe was received at our local express office this morning, in good condition. The agent had never seen one of this type, so upon demonstrating the globe to him, he "fell in love" with it immediately and wrote down your address, saying that he would order one immediately.
(S) S. H. Buchanan,
Radio Operator.

**World Globe
No. P-212**

The 12" standard globe was the first to list principal international short-wave stations and call letters. On this map are printed 67 prominent short-wave stations—quickly recognized since they are printed in red. They are accurate and up-to-date.

Such data as: steamship routes, ocean currents, mountain peaks, principal railroads, Lindbergh's flight, and other useful information will be found on the globe. There are over 5,000 place names shown.

This attractive globe is highly suitable for home, studio, school or office. It is extremely low in price when compared to its beauty and utility value.

A 32-page booklet, well illustrated, entitled "The Story of the Globe" is included with this world globe. Height—16 1/4". Shipping weight—6 1/2 lbs. **\$2.95**
PRICE



All globes are carefully packed in original, corrugated protected, cartons, assuring safe delivery. ORDER BY NUMBER. Send check or money order, plus sufficient postage for delivery by parcel post. Globes are shipped from our Chicago warehouse. Register letter if it contains cash, currency or stamps. Specify if shipment is to be sent express collect. ALL ORDERS ARE FILLED PROMPTLY.

SHORT WAVE CRAFT 99 HUDSON STREET, NEW YORK, N. Y.



**World
Globe
No. P-75**

This beautiful 7" Radio Globe, with 55 principal international short-wave stations and call letters, is attractively mounted in a half ring, with a sturdy spun steel base. The stand is finished in stately bronze.

The highly glazed surface of this ball is scratch-proof as well as water-proof. It shows 2,500 place names; it is printed in seven, rich, beautiful colors. Important geographic information such as: Lindbergh's flight, Byrd's travels through Little America, etc., will be found on the map. Height—10". Shipping weight—2 1/4 lbs. **85c**
PRICE

ORDER YOUR GLOBE TODAY!

SHORT WAVE CRAFT SWC-11-36
99 Hudson St., New York, N.Y.

Gentlemen: Enclosed you will find my remittance of \$..... for which please ship me the following:

World Globe.....

() World Globe No. P-75 @ \$.85
() World Globe No. P-88 @ 1.75
() World Globe No. P-212 @ 2.95
() World Globe No. P-100 @ 3.95

Name.....
Address.....
City..... State.....

Send remittance in check or money order—register letter if it contains cash, stamps or currency. GLOBES ARE SHIPPED FROM OUR WAREHOUSE IN CHICAGO. F.O.B. FROM THAT CITY.

Please mention SHORT WAVE CRAFT when writing advertisers

(Continued from page 451)

quarter tuned parabolic antennae, had a very directional effect and the system was disturbed by the introduction of any metal object like a car within the wave field.

Therefore, it became apparent, that by the introduction of sensitive relays or by use of a photo-electric cell to respond to the neon tube fluctuations; or by any other method that would transmit this change to a rugged outfit, a car operator would be warned of an approach by a light appearing on the dash board; and this would happen approximately 316 feet before he reached the corner and the approaching car or cars would have to be within 250 to 300 feet of the junction.

This detail is being worked out now and there seems little doubt, but that I will be able to produce a very satisfactory system that will warn a car operator so that "crashes" at intersections will be unnecessary.

I am, sincerely,

C. H. WEST,
U. S. Marine Hospital,
Stapleton, N.Y.

(Fine business, "C. H. W." We hope to hear from more of our readers who have a new slant on short waves and their applications.—Editor).

An Answer to the QSL Card Argument
Editor, SHORT WAVE CRAFT:

Referring to page 373 of the October issue I wish to answer through your columns the letter from VK2NO.

What he says about enclosing return postage may or may not be O.K. But personally I can say from experience that I have received QSL's from several amateur men in several foreign countries and I never sent one of them return postage. They were very glad to get my report and thanked me for it, because no matter how I receive a man's signal I will not tell him it is good unless it is. There certainly is no sense in sending out a false report.

He also says a lot about the cost of postage and printing. We have to pay for the printing of our cards and also the postage. So I think if we pay the charges on this end, it is only fair for the fellow on the other end to pay his share, especially if he gets a decent report. Some of the cards I have seen cost plenty, the same as the cards from transmitting amateurs do.

Another word and then I'll "sign off." A lot of well-educated and well-meaning amateurs use the word "ham" when referring to radio amateurs. Now a "ham" is a bum actor and while it is all too true there are a few bum amateurs on the air, the greatest amount of them are regular "he" men.

Yours truly,
R. G. SUMMERS (swl-w8)
(Short Wave Listener, 8th zone.)
84 Marion Street, Buffalo, N.Y.

P.S. A better magazine for the Radio Experimenter and future amateur than Short Wave Craft just isn't being printed—and that's no lie either.

R.G.S.
(Well! Well! It seems there's two sides to this story, too.—Editor).

We're a WOW! He Says

Editor, SHORT WAVE CRAFT:
Would you please be kind enough to publish a note in your magazine that I should like to correspond with any one interested in short-wave radio, whether it be a Y.L. or an O.M. I am a member of the British Long Distance Listeners Club, an organization sponsored by the "Practical and Amateur Wireless" magazine (London) and run along the same lines as your "Short Wave League."

I find your magazine a wow!, beating our English "mags." to a frazzle. Also your list of stations is very useful, as there is only one English "mag." that publishes a list, and this contains only the main stations.

I must close now by wishing your Short Wave Craft every success, and to you "Fans" and "Hams"—grab your pens and send me that reply.—Alex Shillito, 27 Kirkstead St., Hyson Green, Nottingham, England.

(Get busy, boys! Here's your chance to establish that long-desired "foreign" contact.—Editor).

CLASSIFIED

Advertisements are inserted at 5c per word to strictly amateurs, or 10c a word to manufacturers or dealers. Each word in a name and address is counted. Cash should accompany all orders. Copy for the December issue should reach us not later than October 5.

<p>GENERATORS</p> <p>TURN 'EM UP INTO MONEY. Autopower shows you how easily and economically auto generators can be converted into A.C. or D.C. generators and D.C. motors, 2 to 1000 volts; for sound, radio, power, light, or welding. No previous experience necessary—complete information all in new book, with simple instructions and illustrations. Endorsed by thousands. Only \$1.00 postpaid. Autopower, Inc., 414-F So. Hoyne Ave., Chicago.</p>	<p>INSTRUCTION IN RADIO—Engineering design. Experimental Research, Operating, Servicing. Packman Radio Engineering School, Valparaiso, Indiana.</p> <p>WINDING DATA, AUTO ARMATURES, \$1.50. Supreme Electric, 24 W. 20th, New York.</p>	<p>windpower; new farm power or battery. Lowest cost electric lights. Agency—clean up; catalog; free offer. Marco Company, 260 E. 14th, Kansas City, Mo.</p>
<p>"HAM" OFFERS AND WANTS</p> <p>VARIABLE CONDENSERS (any capacity) 3 for \$1.00, Audio Transformers (any ratio) 3 for \$1.00, New 40-watt Amplifier \$31.95. Richard Dawson, 1308-F, The Dalles, Oregon.</p>	<p>MISCELLANEOUS</p> <p>OHM'S LAW CALCULATOR—Lightning Slide Rule; solves all problems of Voltage, Current and Resistance, Power, Wire Sizes, etc. Range: 1 micro-amp. to 1000 amps.; 1 micro-volt to 10,000 volts; 1 micro-ohm to 10 megohms; 1 micro-watt to 10 megawatts; wire sizes 0 to 36 B. & S. gauge. Introductory price \$1.00 prepaid. The Datsprint Co., Box 322, Ramsey, N.J.</p>	<p>SHORT WAVE COMPONENTS</p> <p>PLUG-IN COILS, 15-210 METERS. Space wound on standard four prong forms. 35c set postpaid. Noel, 728 Birch, Scranton, Pa.</p>
<p>McMURDO SILVER CUSTOM built Masterpiece like new. Motorola Philco car sets, Sampson Amplifier. Want Patterson, Hammarlund, Glenn Watt, Chanute, Kansas.</p>	<p>CALL LETTERS, BEAUTIFULLY mounted block letters. Red or green trimmed with aluminum \$1 postpaid. Write, 696 Market St., Wabash, Indiana.</p>	<p>CRYSTALS—MOUNTED OR UN-mounted, W-8-E-8-N.</p> <p>SHORT WAVE RECEIVERS</p>
<p>SKYRIDERS 1936 "SUPER SEVEN" very special price; also RME and other shortwave. Will trade for binoculars, cameras, etc. Wells-Smith, 26 N. Wells St., Chicago.</p>	<p>QSL—CARDS—SWL</p> <p>ATTRACTIVE SHORT WAVE LISTENERS' DX CARDS. Amateur's QSLs. Superlative Quality. Samples (Stamps). W-8-E-8-N, 1827 Cons. Toledo, Ohio.</p>	<p>RECEIVERS—NEW AND USED, sold and traded in. Hammarlund, Nationals, RME, Skydrier, Schwarz Radio Service, 15 Lawrence Ave., Dumont, N. J.</p>
<p>THREE TUBE RECEIVER, POWER supply, 17-200 meters. \$10.00. Unused W2211-D emitting tube \$5.00. M. Chadwick, 35 Selma, Webster Groves, Mo.</p>	<p>QSL SWL CARDS, NEAT, ATTRACTIVE, reasonably priced, samples free. Miller, Printer, Ambler, Pa.</p>	<p>SW CRYSTAL SET—1250 MILE record. Instructions 18 Distance models. "Radiobuilder" year; 25c. Laboratories, 151-A Liberty, San Francisco.</p>
<p>MASTERPIECE IV—ONE ONLY at \$140, like new. Mr. Baltzy, 1711 Riverside, Muncie, Indiana.</p>	<p>RADIO EQUIPMENT</p> <p>THE "KEY OF SUCCESS." Our line of standard and high-speed telegraph keys is world-famous. Best amateur discounts. Write today for free information. Universal Radio, Dept. R 8, Box 40, San Francisco, California.</p>	<p>USE TUBE IN CRYSTAL SET. Adapter 25c. Simplest one tube set kit 60c. H. Black, 12 Lambert St., Belmont, Mass.</p>
<p>AMATEUR RADIO LICENSES, complete training. Resident and correspondence courses. Every graduate a licensed operator. N. Y. Wireless School, 1123 Broadway, New York.</p>	<p>RADIOS</p> <p>FARM AND CITY RADIOS, \$6.95 up; save over 60 per cent; amazingly new farm radio; operates from free</p>	<p>IN STOCK—NEW NATIONAL NC-100 \$105. SW3 \$19.50. Used SW3 \$13.00. Schwarz Radio, Dumont, N.J.</p>

THE ONE AND ONLY
Encyclopedia on Short Waves
By C. R. Leutz and R. B. Gable

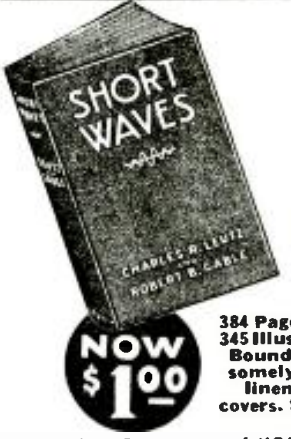

"SHORT WAVES" is written by Leutz and Gable, two foremost radio authorities. You will remember Charles R. Leutz as one of the pioneers in radio, also designer and manufacturer of the famous LEUTZ Transoceanic Receivers. Mr. Robert Gable owned and operated one of the finest low power broadcasting stations in the country. He is well known as an experimenter and research worker in scientific fields. Considering the value of this book for data alone, its cost should really be more than originally asked. But when you see the illustrations in the book you will marvel at how this book could be sold for ONE DOLLAR. It originally sold for \$2.98. The book is printed on a very expensive super-calendered paper. It contains 384 pages with over 345 photographic illustrations and diagrams. The supply of these books is not expected to last long. Once they are gone no additional copies will be available. ORDER NOW—be sure to tell your friends about this remarkable book value. Send the coupon today for your copy of "SHORT WAVES" by Leutz and Gable.

YOU SAVE \$1.98 JUST AS LONG AS THE SUPPLY OF THIS BOOK LASTS! THIS BOOK ORIGINALLY SOLD FOR \$2.98

"SHORT WAVES" is the most important and comprehensive volume of short-waves ever published. This book has EVERYTHING on short-waves—it literally contains a complete education on short-waves.

• Partial Contents of "Short Waves" •

HISTORICAL REVIEW
SHORT WAVE PROPAGATION
COMMERCIAL RADIO TELEPHONY
AND TELEGRAPHY
SHIP TO SHORE RADIO TELEPHONY
DIRECTIONAL ANTENNAE
TELEVISION
AIRCRAFT RADIO EQUIPMENT
SHORT WAVE BROADCAST RECEIVERS
ULTRA SHORT WAVES (Medical and Surgical Applications)
AMATEUR SHORT-WAVE EQUIPMENT

Don't forget that this comprehensive volume is sold on a MONEY-BACK GUARANTEE. If you are not satisfied with it, return it within three days for refund. Use the coupon at the left for ordering your copy of "SHORT WAVES" by Leutz and Gable.

RADIO PUBLICATIONS
103 Hudson St. New York, N. Y.

MAIL COUPON TODAY!

RADIO PUBLICATIONS, Dept. SWC-11-36
103 Hudson Street, New York, N. Y.

Gentlemen: Enclosed you will find my remittance of One Dollar (\$1) cash, money order or new U. S. stamps for which send me One copy of "SHORT WAVES" by Leutz and Gable. I understand this book may be returned to you within three days if I am not completely satisfied and my money refunded.

NAME _____
ADDRESS _____
CITY _____ STATE _____

(Include 15c extra to cover mailing charges; 25c foreign countries)

Please mention SHORT WAVE CRAFT when writing advertisers

Nationally Known 6 1/2 inch DYNAMIC SPEAKERS

1500 ohms. Output transformer to match 38, 12A7, 71A, 43, 45, 2A5, 47, 59, 53 tubes, etc. Shipping weight 6 lbs. AD 600, AD-600 Speaker complete.

- SAME SPEAKER**
 10 1/2 inch, available in the following sizes:
 1000, 1500, 2000 ohm field coils. Brand new, less output transformers. **\$2.29**
10" SPEAKER less transformer **25c**
OUTPUT TRANSFORMERS, extra
 10P 45-2A3 extra **39c**
OUTPUT TRANSFORMERS, single pentode, extra **39c**
 AD-1601 Shipping weight, 10 lbs.

89°C
 As Illustrated



BUILD IT YOURSELF

GREATEST AMPLIFIER BARGAIN EVER OFFERED
40 WATT Undistorted Power Amplifier
EMPLOYS NEW RCA MIRACLE TUBE DEVELOPMENT. 6L6 BEAM POWER OUTPUT TUBES

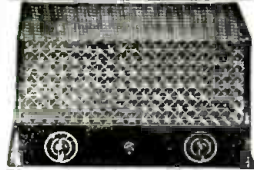

Multiple input channel: velocity microphone 130 DB; crystal microphone 112 DB; carbon microphone 90 DB; phonograph pick up 75 DB. One or two speakers (please specify).
 Electronic mixing and fading system; less than 2% distortion. Through high fidelity response. Variable bass compensator. Universal output transformer with variable impedance from 4 to 500 ohms. Employs new metal 6 tubes. 2-4F5, 1-6C6, 2-81A, 1-5Z3.
AD 1300—Complete kit of parts, with drilled shielded and screened chassis. Less equipment, unwired 13.23
AD 1301—Amplifier wired complete, less tubes 24.95
AD 1302—12-20 Watt 6F6 Amplifier Kit built on same chassis 16.95
AD 1303—15 Watt 6B5 Amplifier Kit 15.95
AD 1304—22 Watt 6B5 Amplifier Kit 17.95
 All Kits Less Tubes, Speakers and Microphones

4-Tube 7 1/2 Watt Amplifier Kit

A beautifully designed amplifier, conservatively rated at 7 1/2 watts. Comprises two-stages—one utilizing a 57 input tube and the other a parallel stage using 2-2A5's. Uses an 80 rectifier. Input to grid of 57. Output from plates of 2A5. Designed for 100 to 130 volts, 50-60 cycles, A.C. Entire system fuse protected. Sold complete with all parts: chassis, wire, hardware, etc., ready to assemble and wire. Detailed diagram included. Ship wt. 15 lbs.

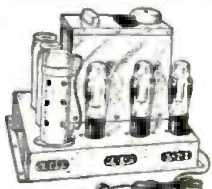

No. AD 112 7 1/2 Watt Amplifier Kit, less tubes, unwired **\$4.95**
 Amplifier, Completely Wired **\$1.00 extra**

Complete Public Address Combination

This combination comprises:
 Completely Wired and Tested 7 1/2 Watt Amplifier, described above **\$5.95**
 1—Faraday Double Button Professional Carbon Mike **\$2.95**
 1—Paragon Professional Double Button Mike **\$3.95**
 1—Telescopic Chromium Plated Microphone Floor Stand **\$2.29**
 1—10" Dynamic Speaker **\$3.95**
 1—Microphone Input Box **\$2.95**
 1—Set of Matched Tubes **\$1.95**
Special Price for Complete System **\$16.95**
 Add \$1.00 extra for Paragon Mike—Add 5c per ft. for 3-wire shielded mike cable—Add 6c per ft. for 4-wire shielded speaker cable.

NO ORDER FOR LESS THAN \$1.00 WILL BE ACCEPTED. ALL REMITTANCES MUST INCLUDE A SUFFICIENT AMOUNT TO COVER POSTAGE AND INSURANCE. NO C.O.D. ORDERS FILLED UNLESS ACCOMPANIED BY A 25% DEPOSIT.

What Is It?

Radio Experimenter's Surprise Package

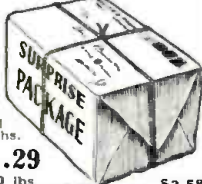

A large box chock full of assorted radio parts, worth over \$10.00—parts that any radio experimenter and set builder can use. All brand new—no junk. Weight 20 lbs.

Surprise Kit **\$1.29**
 AD-1260
 Giant Surprise Kit, weight 40 lbs. **\$2.58**

General Electric Phonograph Motor

This is the same sturdy motor used in the highest quality phonographs and combinations. List Price \$18.92 complete with turntable. Designed for 110-120 volts, A.C., and available for either 25 or 60 cycles (please specify which when ordering). For 78 RPM records. Ship wt. 10 lbs. No. AD-106

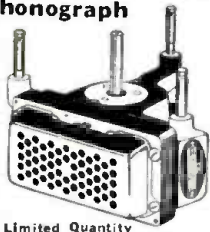

YOUR PRICE **\$3.95** Limited Quantity

Yaxley Band-Changing Switch

Designed especially for all-wave sets. Heavy silver plated contacts. Consists of six 2-gang decks—12 gangs in all. Three positions. Excellent for short-wave as well as for analyzers. List price \$4.32.

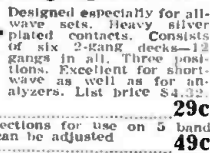

Shipped wt. 1 lb. No. AD-111 **29c**
 AD 112A. Three double sections for use on 5 band all wave radios—5 stops—(can be adjusted to 12 stops) **49c**

CCA Wet Electrolytic Filter Condenser

500 Volts
 4 MFD **20c**
 6 MFD **23c**
 8 MFD **25c**
 10 MFD **35c**
 12 MFD **38c**
 14 MFD **40c**
 16 MFD **45c**

MICA BY PASS CONDENSERS

1000 volt test, 600 working volts. Available in the following sizes:
 .00001 .0015 .0025
 .0007 .0001 .0013
 .001 .0002 .00025
 .002 .0003
 Special price while they last. In lots of 100 **\$0.95** for **.60**
 Single units **.03**
 AD1311

Two & Three-Gang Midget Tuning Condensers

Midget variable condenser cap. .000365 MFD
 3 gang has 3/8" shaft
 2 gang has 1/4" shaft
 AD113—3 Raitk. **59c**
 AD 113A—2 gang.

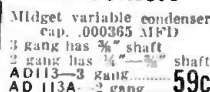

Universal Output Transformer

A real output transformer that will handle the output of any PA system. Secondary impedances variable, from 15 ohm in steps up to 500 ohms. Primary will match any tube in triode, pentode, push-pull, parallel or single output. Impedances will match the new 6L6, 6B5 and all other output tubes on the market. Excellent audio response. Color coded chart with each. Shipping weight, 5 lbs. AD 104 **\$1.49**



FREE 64-page catalog and treatise. Send stamp for our FREE treatise and catalog which contains much valuable data and radio information. There is no obligation involved. Absolutely free. Book sent by return mail.

SPECIAL TUBE OFFER

DILCO R. C. A. Licensed 100% Triple Tested TUBES

YOUR CHOICE ANY GROUP **ONLY \$1.00**

Quan.	Type	Quan.	Type	Quan.	Type
3	50	4	31	4	81
2	12A7	6	71A	4	616
3	2A3	6	56	4	5Z3
12	27	2	19	4	33
6	26	4	24A	6	46
6	01A	4	35-51	1	1A8
6	12A	4	36	3	484
4	4	4	47	3	485

866 RECTIFIERS **89c**
 6E5-6E5 Magie Eye **2 for \$1.00**
 New 6B5 high output audio tube, 3 for **\$1.00**

Also these new metal glass Octal base tubes. **2 FOR \$1.00**

1 D 7	5 Y 3	6 F 7
1 D 5	6 H 6	5 Z 4
1 E 5	6 K 7	6 A 8
1 C 7	6 A 6	5 Z 5
1 F 5		6 Z 5
25 A 6	1 H 4	6 P 5
6 C 5	1 H 6	6 P 6
6 L 7	1 J 6	25 Z 6

Output Transformer for Dynamic Speakers

Matches any speaker, voice coil for 4 to 15 ohms, push pull for pentode, triode tubes. AD105 **25c**

AC-DC Filter Chokes
 Small, compact units designed for use in AC-DC midget sets. Will pass 60 mcs. No. AD-110 **25c**

AD-491 CRL Volume Control Potentiometer
 5,000 25,000 100,000 ohm **25c**
2 1/2 MH. SHORT WAVE R. F. CHOKE 15c
 AD 304

These low loss Chokes are used in every S. W. Set. Complete parts in stock for all diagrams appearing in Short Wave Craft, Radio Craft, QST, Popular Mechanics, etc.

Short-Wave Plug-In Coils
 Designed for use with the Boerle or other standard regenerative circuits using .00014 mfd. condensers. Range 15 to 200 meters. 2-winding coils. Ship wt. 1 lb.
 No. R-100 Set of 4 Coils. **49c**
 No. R-101 Set of 4 Coils for Electron Coupled Circuit as described in QST-5 prong. **69c**

PRESTO PHONOGRAPH PICK UP
 11 1/2" impedance. Brand new, 12" self-balancing arm. Last price \$10.00. Special price while they last **\$3.75**
 AD-1309X

Midget Variable Condensers
 Excellent for use as antenna trimmers in short-wave sets and as variable tuning condensers. Capacity approximately 20 mfd. Sold complete with knob and pointer. Single hole mounting. 9 solid brass plates. Ship wt. 1/2 lb. No. AD-117 **YOUR PRICE 25c**

BUILD YOUR OWN RADIO SETS

5-Tube Super Het Kit
 Comprising of 1 oscillator, 2-156 KC. Double Tuned I-F Transformers—1 Antenna coil, 1-2 gang oscillator tuning condenser, complete with wiring diagram, ready to use. **\$1.75**

Drilled Chassis to Match 29c
 Kit of other essential parts to complete set including condensers, resistors, choke filter, volume control, nuts, bolts, etc., AD-900—Super Het Kit. Complete less tubes **\$2.39**
 AD-900A Individual 456 K.C.I.F. Transformer, 49c
 Set of Five Matched Tubes **\$2.95**

4-TUBE TRF KIT

4-tube TRF circuit, operates on AC/DC current. Complete set with drilled chassis, ready to wire with wiring diagram, includes 3" dynamic speaker hardware, etc., less tubes and cabinet. **\$4.95**
 Kit completely wired, extra **1.00**
 Same kit, magnetic speaker **4.49**
 Kit of 4 tubes **2.25**
 AD 204 Walnut cabinet to match **1.75**

BANDSPREAD VARIABLE CONDENSERS

Available with 11 plates, (approx. .00025 mfd); 13 plates, (.0003 mfd); 17 plates, (.000365 mfd); 23 plates, (.0005 mfd); 48 plates, (.001 mfd). For short-wave bandspread receivers as well as for standard broadcast and long-wave receivers. Ship. wt. 2 lbs. No. AD-116 Variable Condensers—each **25c**

G. E. POWER TRANSFORMER

Manufactured by General Electric. A well designed transformer. Has 6.3 volt filament winding. Designed for 110-125 volts, 50-60 c., A.C. Specifications: 0.3 V. 2 1/2 amp.; 5 V. 2 amp.; for fil. of 80 tube; 750 V., C.T., 75 mfd. for plate current. Ship. wt., 5 lbs.; also available in 2 1/2 V. No. AD-101, 6 to 7 tube transformer, 75 mfd. **99c**
 No. AD-102, 7 to 8 tube transformer, 100 mfd. **\$1.49**
 No. AD-103, 8 to 10 tube transformer, 125 mfd. **\$1.96**
 Unshielded power transformer. Same type as illustrated above. 6.3 fil. volts only.
 AD 201—6-tube unshielded transformers. **85c**
 AD 202—8-tube unshielded transformers. **85c**
 AD 203—10-tube unshielded transformers. **1.15**

R. M. A. Color Coded Carbon Resistors

These are all Brand New Stock. 100 Assorted sizes 50 ohm—5 meg ohm. 1/4" watt sizes guaranteed 10% accuracy resistors. Complete assortment **\$1.29**
 100 resistors. Individual sizes **.3c**
 AD 185—shipping weight 4 lbs.

Hum Free Power Supply Pack

This Pack will supply 2.5 volt Filament voltage. Pure Rectified D.C. 350 volts at 80 MILS 6 AMPs for Filament. Same Pack supplies 6-7 tubes at 6.3 volts. **\$2.95**
 Same Pack supplies 8-9 tubes at 6.3 volts. **\$3.39**
 Same Pack supplies 10-12 tubes at 6.3 volts. **\$4.25**
Complete Kit \$2.49
 with wiring diagram and drilled chassis less tube, unwired. Wiring 30c extra
 tra AD-201, 80-Rectifier tube extra **34c**. Shipping weight, 12 lbs.

RADIO BOOKS, published by the RCA Institute, Radio Telegraphy and Telephony, Vacuum Tubes, Modern Radio Operation, Preparatory Mathematics relating to Radio, Acquiring the Code. Average value of these books—over \$2.00 each **25c**
 PER VOLUME



UNITED RADIO COMPANY
 Successors to Radio Trading Company
58 MARKET STREET Dept. S-11 NEWARK, N. J.



Please mention SHORT WAVE CRAFT when writing advertisers

HAM Radio Valuable in Spanish Conflict

Editor, SHORT WAVE CRAFT:

As you are undoubtedly aware, we have unfortunately a civil war over in our country and it so happens that many HAM radio operators with stations located both under Government controlled and uncontrolled areas have proved to be of great assistance, especially since telegraphic, postal and telephone communications have been stopped between several cities, and many relatives living in different parts of Spain have resorted to these HAMS in order for them to radiate messages inquiring about the whereabouts of their relatives, friends, etc. This has proved to be a very efficient service, which keeps these amateurs exceedingly busy transmitting and receiving such messages, as this is the only means of communication.

The Government has forbidden the use of such transmitters and has authorized one or two to operate in each city, in order to prevent their crowding the air with speeches. Now these few remaining stations are transmitting almost exclusively SOS messages, but from time to time they radiate "news" about the trend of things. It is interesting indeed to observe these speeches as, immediately after one has finished and expects the reply of the one to whom he was speaking, there appears another of the "opposite side" trying to contradict it. You will easily realize that at present, instead of searching for "DX" stations, we discard these and much prefer

to look for national HAMS, who usually work on the 40 meter band.

Yours truly,
F. Oliveras Sarri,
Agente Commercial Colegiado,
Pasaje Marimon, 18,
Barcelona, 29th July, 1936.

(Thanks, and we hope to hear more "HAM" news from Spain!—Editor).

NEW S-W STATIONS
Compiled by Joseph H. Miller
EST

- VQG—15.28 meters, 1962 mc.—Kenya Colony, works GAD, 7:30-10 a.m.
- ITK—18.31 meters, 16,385 mc. Italian Somaliland phones Rome often, days.
- JVD—18.91 meters, 15,86 mc.—Japan, phones XOJ, daily.
- XOJ—18.99 meters, 15,80 mc.—Shanghai, China, phones JVD 8-12 p.m. daily.
- (Also works JVF occ., instead of JVD.)
- JZA—19.13 meters, 15,68 mc.—Japan, heard early mornings.
- PLH—19.82 meters, 15.13 mc.—With NIROM Network, 4:30-11 a.m. daily.
- PSE—20.09 meters, 14,935 mc.—Marapieu, Brazil, phones US early evenings.
- JVG—20.12 meters, 14.91 mc.—Japan, with JVH, phones GBL near 7-8 a.m.
- ROU—20.29 meters, 14.79 mc.—Omsk, Siberia, phones Moscow near 7-8 a.m.
- PMK—26.09 meters, 11.50 mc.—Java, with NIROM network, mornings, irreg.
- EHZ—28.93 meters, 10.37 mc.—Tenerife, Canaries, phones EDN-EHY near 5-6 a.m.
- ICK—31.71 meters, 9.46 mc.—Tripoli, phones IAC, 3 a.m.; 6 a.m. and irreg.
- TYA2—33.19 meters, 9.037 mc.—Paris, phones Algiers daily.
- Algiers—33.48 meters, 8.96 mc.—Phones Paris, 12:30-1:30 a.m.; 4-5:30 p.m.

NEW!
The Radolek New 1937 Radio Profit Guide is the most complete Radio Parts Catalog ever published. Completely revised—right up to the minute, bringing you everything in Radio—and Public Address—at the right prices. Every page brings you extra profits! Contains over 10,000 Individual Radio Repair Parts—hundreds of new items—a complete new selection of Radio Receivers, P. A. Amplifiers, Tools, Tubes, Books and Test Instruments. Everything you need—always in stock—ready for prompt shipment to you. You need this Big Radio Parts Catalog—it's FREE!

Send for It!

RADOLEK

630 W. Randolph Street, Chicago, Illinois.

Name

Address

Service man? Dealer? Experimenter?

Index to Advertisers

A		Metal Cast Products Co.	449
Ace Radio Laboratories	122, 440	Midwest Radio Corp.	Inside Front Cover
Allied Engineering Institute	126, 413	N	
Allied Radio Corp.	129	National Company, Inc.	Inside Back Cover
American Microphone Co.	431	National Radio Institute	Back Cover
American National Red Cross, The	151	National Schools	437
Amperite Co.	149	New York Y.M.C.A. Schools	437
Aero Tube Co.	440	O	
Astatic Microphone Laboratory, Inc.	439	O'Brien, Clarence A. & Berman, Hyman	430
B		Ohmite Manufacturing Co.	431
Biley Electric Co.	435	Oxford-Tartak Radio Corp.	438
Brush Development Co., The	141	P	
Bud Radio, Inc.	145	Par-Metal Products Corp.	128
Burstein-Appleber Co.	439	Peak Radio Products	428
C		Pilot Radio Corporation	456
Cameradio Co.	110	Polk, R. L. & Co.	451
Candler System Co.	436	R	
Cannon, C. F., Co.	113	Radio & Television Institute	437
Cardwell, Allen D. Mfg. Corporation, The	129	Radio City Products Co.	433
Centrallion Engineering Co.	430	Radio Constructors Laboratories	423
Classified Advertisements	153	Radio-Craft	145
Cornell-Dubilier Corporation	145	Radio Handbook, The	451
Coyne Electrical & Radio School	387	Radio Publications	442
Crosley Radio Corp., The	134	Radio Service Inst.	436
D		Radio Training Assn. of America	437
Dataprint Company	144	Radolek	155
Deutschmann, Tope, Corp.	143	RCA Institutes, Inc.	437
Dodge's Institute	437	S	
E		Sargent, E. M., Co.	433
Eilen Radio Laboratories	121	Scott, E. H., Radio Laboratories, Inc.	131
Electrad, Inc.	133	Short Wave Coil Book	117
F		Short Wave League	447, 448
First National Television, Inc.	136	Short Wave Manual	413
G		Short Waves	453
General Cement Mfg. Co.	135	Silver, McMurdo Corp.	449
Gold Shield Products Co.	141, 147	Sprayberry Academy of Radio	426
Goldentone Radio Co.	141	Superior Instruments Co.	439
Goodheart-Willeox Company, Inc., The	145	T	
Guy Stokely Radio Corp.	127	Teleplex Co.	437
H		Thordarson Electric Mfg. Co.	417
Halliewafters, Inc.	435	Trimm Radio Manufacturing Co.	441
Hammarlund Manufacturing Co., Inc.	175	Triplet Electrical Instrument Co.	432
Harrison Radio Company	128	Fry-Mo Radio Co., Inc.	438
I		U	
Instructograph Company	136	Ultra High Frequency Products Company	425
J		Uncle Dave's Radio Shack	430
Jobs & Careers	151	United Radio Company	454
K		V	
Korrol Mfg. Co., Inc.	131	Vibroplex Co.	449
L		W	
Lancaster, Allwine & Rommel	138	Wellworth Trading Company	444, 447
Lifetime Corp., The	138	Wholesale Radio Service Co., Inc.	385
Mc		Winn, J. H., Mfg. Co.	441
McElroy, T. R.	136	Woman's Digest	447
McGraw-Hill Book Co., Inc.	424	X	
M		X. L. Radio Laboratories	438
Marine Radio Company	128	(While every precaution is taken to insure accuracy, we cannot guarantee against the possibility of an occasional change or omission in the preparation of this index.)	
Massachusetts Radio School	447		
Meissner Mfg. Co.	455		

REMOTE CONTROL Adaptor Unit

At last! A remote control unit that operates efficiently. No complicated motors, relays, etc., which made the old time remote controls impractical. The only connections necessary are a single duplex wire from the unit to the receiver and the insertion of the AC plug into a wall receptacle. Unit is completely self powered and needs no batteries or leads to the power supply of the receiver. Operates independently of the radio controls on the receiver. Ideal for homes and a positive necessity for invalids, taverns, restaurants, etc. The arm chair lover's companion. The possibilities of this unit are unlimited. Etched and polished control escutcheons. Bakelite bar type control knobs. Black crystal finished metal chassis. Entire assembly is attractively finished. Completely assembled and ready to wire. Detailed diagrams and instructions supplied. Uses 1 type 25Z6, and 1 type 6AS all metal tubes.

MODEL No. 7520—Remote control unit for broadcast reception..... \$11.50

SOLD BY ALL LEADING JOBBERS

MEISSNER MFG. CO.
Mt. Carmel Illinois

Please mention SHORT WAVE CRAFT when writing advertisers

Radio Builders Since 1908

\$74.50

Model 293, for AC current

\$79.50

Model 298, for DC current



"The Standard of Excellence"

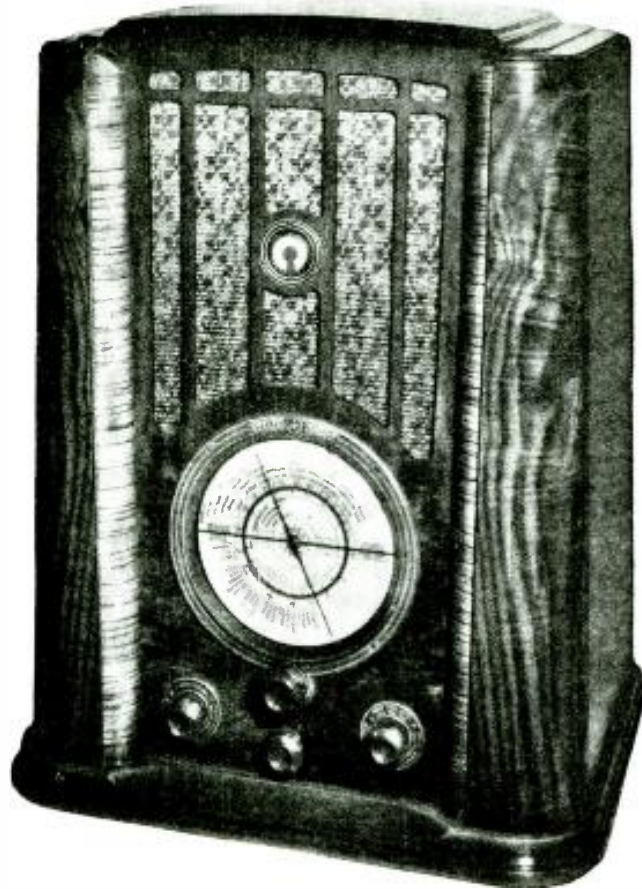

Pilot All-Wave Radio for Extreme DX Reception

Declared by DX experts to surpass performance of the most expensive "communications type" receivers

Delivers Pilot's world-famed Peak Performance on 16 to 550 meters—Provides latest technical refinements and improvements—Designed in the Pilot Radio laboratories which produced the first all-wave radio receiver designs, and which still lead in their development.

SPECIFICATIONS

Cabinet: Rare walnut veneers, 20 ins. high, 15½ ins. wide, 11¼ ins. deep.

Standard Tuning: Models 293 and 298 have 3 bands, covering 16-550 m. (18,800-545 kc.).

Dial Logging: All important stations logged on the dial.

Tuning Beacon: No. 6G5 cathode ray Tuning Beacon indicates exact tuning.

Selective Lighting: Band switch controls lighting of tuning scales.

2-Speed Tuning: Push-pull control provides 95:1 or 12:1 ratio.

Superheterodyne: Engineering refinements set new standards of performance.

Amplifier: Class A power pentode amplifier.

Diode Detection: Linear rectification prevents distortion.

Tone Control: Adjustable audio filter matches tone to type of incoming program.

Automatic Volume Control: Improved high-sensitivity A. V. C.

10-Tube Performance: This is accomplished by using the 6A8 as 1st detector and oscillator, and combining the 2nd detector, AVC, and first audio stage in the 6Q7 tube.

AC Tubes: Model 293 has two 6K7, one 6A8, one 6Q7, one 6F6, one 5W4, one 6G5.

DC Tubes: Model 298 has two 6K7, one 6A8, one 6Q7, two 25A6, one 6G5.

Complete Shielding: New, extra shielding, and integral grounds to chassis.

Pre-Selection: R.F. amplifier increases receiving range and reduces interference on all bands.

Loudspeaker: 8-in. concert-range dynamic speaker.

Acoustic Compensator*: Mounted within speaker cone, breaks up straight-line projection of higher audio frequencies, and provides adequate diffusion.

Phonograph Jack: For high-impedance phono pickup.

Live Rubber Mountings: All vital parts cushioned from shocks and vibration.

Extra Speaker Socket: For 10,000-ohm permanent magnet dynamic speaker.

Net Weight: 39 lbs. or 17½ kilos.

*Patent applied for.

YOU CAN ORDER THIS SET THROUGH YOUR LOCAL RADIO DEALER

"The Standard of Excellence"

Pilot

RADIO CORPORATION

3701 THIRTY-SIXTH STREET, LONG ISLAND CITY, N. Y.

Please mention SHORT WAVE CRAFT when writing advertisers

KABLE BROS. CO., PRINTERS

In the U. S. A. and
92 Foreign Countries

NEW AS TOMORROW!

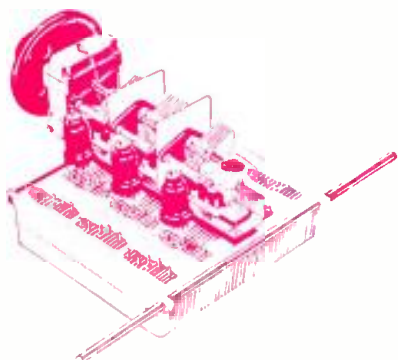

The Movable-coil Tuning Unit, heart of the NC-100, is an invention that makes it possible to shift plug-in coils by the twist of a knob on the front panel. The illustration above shows the heavy cast aluminum shield containing the fifteen HF coils, each in its own shielded compartment. The turn of a knob slides this shield along its smooth-running track, and locks the desired set of coils into exact position directly below the tuning condenser.



Each of the fifteen HF coils is in its own shielded compartment, and idle coils are completely out of the way. Rugged, silver-plated, side-wipe contacts provide dependable circuit connections of low resistance. Leads are short. Calibration is permanent. For high signal-to-noise ratio, low-loss construction is used throughout. Air dielectric condensers are used for trimming circuits and R-39 is used for insulation.

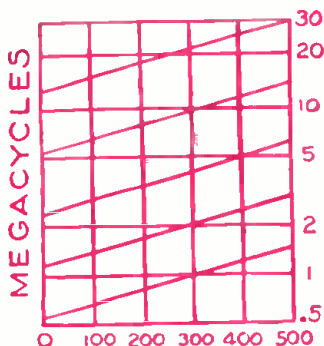

The calibration of the NC-100 is permanent and precise. The accurate construction of the range-changing mechanism gives validity to the exactness of the Micrometer Dial. Readings are direct to one part in five hundred. The tuning range for any given set of coils is only about 2.4 to one, so that stations are well spread out. Five ranges in all are provided, giving overlapping coverage from 540 KC to 30 MC.

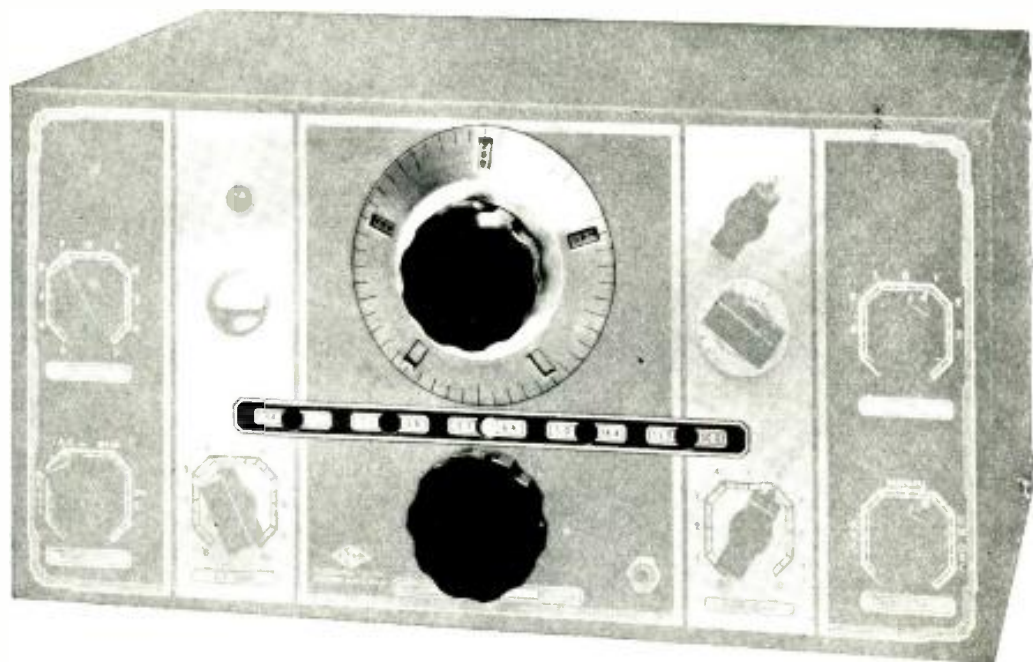

NATIONAL NC-100 12 TUBE SUPERHETERODYNE

There is no need to print testimonial letters on the NC-100, for its design and its performance speak for themselves. It is powerful. It is precise. It is amazingly effective in bringing in weak signals. It is *quality*.

Typical of its advanced design is the Movable-Coil Tuning Unit, which combines the convenient range-changing of the coil switch with the uncompromised efficiency of the plug-in coil. Each of the fifteen HF coil assemblies is a self-contained unit, complete with air-dielectric trimming condenser and low-loss R-39 mounting. Each is mounted in its own shielded compartment; and each, when in use, is brought close to the tuning condenser and the tubes where it is plugged into the circuit by rugged, positive contacts. Idle coils are moved entirely out of the way, completely isolated and thoroughly shielded. There are no dead spots in the NC-100.

Vital to the precision of the tuning system are the geared tuning condenser and the Micrometer dial, with readings direct to one part in five hundred. Tuning is smooth and logging is accurate. Condenser stators have four-point mounting on bars of low-loss Isolantite, rotors are individually insulated from the condenser frame. Important connections are made with heavy bus wire. Every detail contributes to the constancy of circuit characteristics so essential to permanently reliable calibration.

The circuit also has received its share of attention. For example, separate tubes, electron coupled, are used for high frequency oscillator and first detector. A bias-type power detector and a separate tube for amplified and delayed AVC relieve the second IF stage of the undesirable loading caused by diode rectifiers. From preselector to push-pull output, no pains have been spared to make the NC-100 as outstanding in performance as it is in precision.

Convenient and complete control is an important feature of the NC-100 receiver. Separate Audio and RF Gain Controls, Tone Control, and Crystal Filter controls for Phasing and Selectivity are all brought out to the front panel, as is also the tuning adjustment for the CW oscillator. Switches are provided for cutting plate voltage during transmission, and for rejecting the AVC. But most important of all to the dyed-in-the-wool DX fan are the smooth tuning and precise logging contributed by the Micrometer Dial and the Movable-coil Range Changing.

Drop in at your dealer's and study this unusual receiver. He will be proud to explain its many features to you. Or if more convenient, write for a copy of the illustrated folder describing the NC-100. It is free for the asking, and no coupon is needed. Just send a postcard, saying you are a Short Wave Craft reader and would like a copy of the NC-100 folder. Be sure to write your name and address clearly.

NATIONAL COMPANY, Inc.



**MALDEN
MASS., U.S.A.**

How a "Tip" got Tom a Good Job

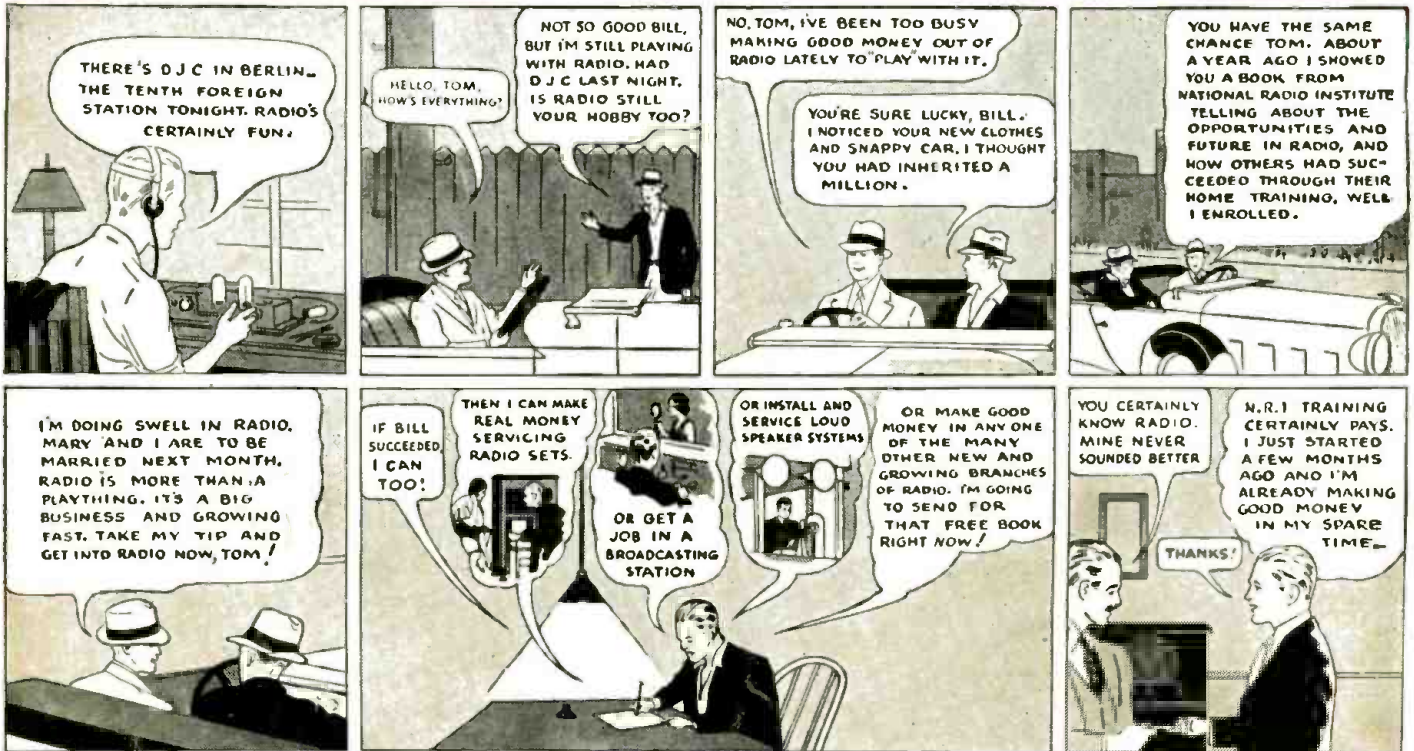

HERE'S PROOF THAT N.R.I. MEN MAKE GOOD MONEY



\$3,500 a Year in Own Business

"After completing the N. R. I. Course I became Radio Editor of the Buffalo Courier. Later I started a Radio service business of my own, and have averaged over \$3,500 a year."—T. J. TE-LAAK, 457 Broadway, New York City.

\$10 to \$25 a Week in Spare Time

"I am making from \$10 to \$25 a week in spare time while still holding my regular job as a machinist. I owe my success to N. R. I."—WM. F. RUPP, 130 W. 6th Street, Conshohocken, Pa.



GET MY FREE LESSON on Radio Servicing Tips



I'll prove that my Training is practical, money-making information, that it is easy to understand—that it is just what you need to master Radio. My lesson text, "Radio Receiver Troubles—Their Cause and Remedy" covers a long list of Radio receiver troubles in A. C., D. C., battery, Universal, auto., T. R. F., superheterodyne, all-wave and other types of sets. And a cross reference system gives you the probable cause and a quick way to locate and remedy these set troubles. A special section is devoted to receiver check-up, alignment, balancing, neutralizing and testing. Get the lesson free. No obligation. Just mail coupon.

... I will train you to start a spare time or full time Radio service business Without Capital

Many Radio Experts Make \$30, \$50, \$75 a Week



J. E. Smith, President National Radio Institute

Do you want to make more money? The world-wide use of Radio sets has made many opportunities for you to have a spare time or full time Radio service business of your own. Three out of every four homes in the United States have Radio sets which regularly require repairs, servicing, new tubes, etc. Many sets are old and will soon be replaced by new models. I will train you to sell, install, service all types of Radio sets—to start your own Radio service business and build it up. Mail coupon for my 64 page book. It's FREE.

Get Ready Now for a Business of Your Own and for Jobs Like These

Broadcasting stations employ engineers, operators, station managers and pay to \$5,000 a year. Spare time Radio set servicing pays as much as \$200 to \$500 a year—full time Radio servicing jobs as much as \$30, \$50, \$75 a week. Many Radio Experts own and operate their own full time or part time Radio sales and service businesses. Radio manufacturers and jobbers employ testers, inspectors, foremen, engineers, servicemen, paying up to \$6,000 a year. Radio operators on ships get good pay and see the world besides. Automobile, police, aviation, commercial Radio, and loud speaker systems offer good opportunities now and for the future. Television promises many good jobs soon. Men I have trained at home are holding jobs in all these branches of Radio. Read their statements in my 64 page book. Mail the coupon.

Many Make \$5, \$10, \$15 a Week Extra in Spare Time While Learning Practically every neighborhood needs a good spare time serviceman. The day you enroll I start sending you Extra Money Job Sheets. They show you how to do Radio repair jobs that you can cash in on quickly. Throughout your training, I send you plans and ideas that have made good spare time money for hundreds of fellows. I give you special Radio equipment for conducting experiments and building circuits which illustrate important Radio principles. My Training gives you practical experience while learning.

Find Out What Radio Offers You

Mail the coupon now for my Lesson on Radio Servicing TIPS and my book, "Rich Rewards in Radio." Both are free to anyone over 16 years old. My book describes Radio's spare time and full time opportunities, and those coming in Television; tells about my Training in Radio and Television; tells about my Money Back Agreement; shows you actual letters from men I have trained, telling what they are doing and earning. Find out what Radio offers YOU! MAIL THE COUPON in an envelope, or paste it on a penny postcard—NOW!

J. E. SMITH, President NATIONAL RADIO INSTITUTE, Dept. 6MB3, Washington, D. C.

Dear Mr. Smith: I want to take advantage of your offer Without obligating me, send me your Free Lesson and your book, "Rich Rewards in Radio." (Please write plainly.)

NAME.....
 ADDRESS.....
 CITY.....
 STATE..... TAXI

J. E. SMITH, President National Radio Institute, Department 6MB3, Washington, D. C.

MAIL THIS. Get a lesson and 64 page book FREE

If you do not want to cut this cover—simply write us on a post card